

# MAC228A

## Sensitive Gate Triacs – 400V - 800V



### Description

Designed primarily for industrial and consumer applications for full-wave control of AC loads such as appliance controls, heater controls, motor controls, and other power switching applications.

### Features

- Sensitive Gate Triggering in 3 Modes for AC Triggering on Sinking Current Sources
- Four Mode Triggering for Drive Circuits that Source Current
- All Diffused and Glass-Passivated Junctions for Parameter Uniformity and Stability
- Small, Rugged, Thermowatt Construction for Low Thermal Resistance and High Heat Dissipation
- Center Gate Geometry for Uniform Current Spreading
- These Devices are Pb-Free and are RoHS Compliant

### Additional Information



Resources



Accessories



Samples

### Functional Diagram

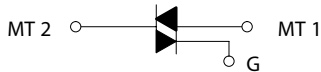

### Pin Out

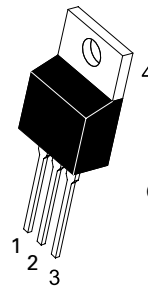

**TO-220AB  
CASE 221A  
STYLE 4**

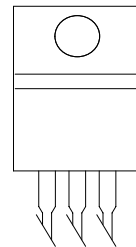

## MAC228A

## Sensitive Gate Triacs – 400V - 800V

Maximum Ratings ( $T_J = 25^\circ\text{C}$  unless otherwise noted)

Rating	Symbol	Value	Unit
Peak Repetitive Off-State Voltage (Note 1) ( $T_J = -40$ to $110^\circ\text{C}$ , Sine Wave, 50 to 60 Hz, Gate Open)	MAC228A4 MAC228A6 MAC228A8 MAC228A10	$V_{\text{DRM}}$ $V_{\text{RRM}}$	200 400 600 800 V
On-State RMS Current ( $T_C = 80^\circ\text{C}$ ) Full Cycle Sine Wave, 50 to 60 Hz	$I_{\text{T (RMS)}}$	8.0	A
Peak Non-Repetitive Surge Current (One Full Cycle Sine Wave, 60 Hz, $T_J = 110^\circ\text{C}$ )	$I_{\text{TSM}}$	80	A
Circuit Fusing Consideration ( $t = 8.3$ ms)	$I^2t$	26	A <sup>2</sup> sec
Peak Gate Current, ( $t \leq 2$ $\mu\text{s}$ , $T_C = 80^\circ\text{C}$ )	$I_{\text{GM}}$	$\pm 2.0$	A
Peak Gate Voltage, ( $t \leq 2$ $\mu\text{s}$ , $T_C = 80^\circ\text{C}$ )	$V_{\text{GM}}$	$\pm 10$	V
Peak Gate Power ( $t \leq 2$ $\mu\text{s}$ , $T_C = 80^\circ\text{C}$ )	$P_{\text{GM}}$	20	W
Average Gate Power ( $t \leq 8.3$ ms, $T_C = 80^\circ\text{C}$ )	$P_{\text{G (AV)}}$	0.5	W
Operating Junction Temperature Range	$T_J$	-40 to +110	$^\circ\text{C}$
Storage Temperature Range	$T_{\text{stg}}$	-40 to +150	$^\circ\text{C}$
Mounting Torque	–	8.0	in lb

Maximum ratings are those values beyond which device damage can occur. Maximum ratings applied to the device are individual stress limit values (not normal operating conditions) and are not valid simultaneously. If these limits are exceeded, device functional operation is not implied, damage may occur and reliability may be affected.

1.  $V_{\text{DRM}}$  and  $V_{\text{RRM}}$  for all types can be applied on a continuous basis. Ratings apply for zero or negative gate voltage; however, positive gate voltage shall not be applied concurrent with negative potential on the anode. Blocking voltages shall not be tested with a constant current source such that the voltage ratings of the devices are exceeded.

## Thermal Characteristics

Rating	Symbol	Value	Unit
Thermal Resistance, Junction-to-Case (AC) Junction-to-Ambient	$R_{\theta\text{JC}}$ $R_{\theta\text{JA}}$	2.0 62.5	$^\circ\text{C/W}$
Maximum Lead Temperature for Soldering Purposes, 1/8" from case for 10 seconds	$T_L$	260	$^\circ\text{C}$

Electrical Characteristics - OFF ( $T_J = 25^\circ\text{C}$  unless otherwise noted ; Electricals apply in both directions)

Characteristic	Symbol	Min	Typ	Max	Unit
Peak Repetitive Blocking Current ( $V_D = V_{\text{DRM}} = V_{\text{RRM}}$ ; Gate Open)	$I_{\text{DRM}}$ $I_{\text{RRM}}$	-	-	10	$\mu\text{A}$
		-	-	2.0	mA

Electrical Characteristics - ON ( $T_J = 25^\circ\text{C}$  unless otherwise noted; Electricals apply in both directions)

Characteristic	Symbol	Min	Typ	Max	Unit
Peak On-State Voltage ( $I_{\text{TM}} = \pm 11$ A Peak, Pulse Width $\leq 2$ ms, Duty Cycle $\leq 2\%$ )	$V_{\text{TM}}$	–	–	1.8	V
Gate Trigger Current (Continuous dc) ( $V_D = 12$ V, $R_L = 100$ $\Omega$ )	MT2(+), G(+)	–	–	5.0	mA
	MT2(+), G(–)	–	–	5.0	
	MT2(–), G(–)	–	–	5.0	
	MT2(–), G(+)	–	–	10	
Gate Trigger Voltage (Continuous dc) ( $V_D = 12$ V, $R_L = 100$ $\Omega$ )	MT2(+), G(+)	–	–	2.0	V
	MT2(+), G(–)	–	–	2.0	
	MT2(–), G(–)	–	–	2.0	
	MT2(–), G(+)	–	–	2.5	
Gate Non-Trigger Voltage (Continuous DC), ( $V_D = 12$ V, $T_C = 110^\circ\text{C}$ , $R_L = 100$ $\Omega$ ) All Four Quadrants	$V_{\text{GD}}$	0.2	–	–	V
Holding Current ( $V_D = 12$ V, Gate Open, Initiating Current = $\pm 200$ mA)	$I_{\text{H}}$	–	–	15	mA
Gate-Controlled Turn-On Time, ( $V_D = \text{Rated } V_{\text{DRM}}$ , $I_{\text{TM}} = 16$ A Peak, $I_G = 30$ mA)	$t_{\text{gt}}$	–	1.5	–	$\mu\text{s}$

# MAC228A

## Sensitive Gate Triacs – 400V - 800V

### Dynamic Characteristics

Characteristic	Symbol	Min	Typ	Max	Unit
Critical Rate of Rise of Commutation Voltage ( $V_D = \text{Rated } V_{DRM}$ , $I_{TM} = 11.3 \text{ A}$ , Commutating $di/dt = 4.1 \text{ A/ms}$ , Gate Unenergized, $T_C = 80^\circ\text{C}$ )	$di/dt_{(c)}$	–	5.0	–	$\text{V}/\mu\text{s}$
Critical Rate of Rise of Off-State Voltage ( $V_D = \text{Rated } V_{DRM}$ , Exponential Waveform, Gate Open, $T_C = 110^\circ\text{C}$ )	$dv/dt$	–	25	–	$\text{V}/\mu\text{s}$

Product parametric performance is indicated in the Electrical Characteristics for the listed test conditions, unless otherwise noted. Product performance may not be indicated by the Electrical Characteristics if operated under different conditions.

### Voltage Current Characteristic of SCR

Symbol	Parameter
$V_{DRM}$	Peak Repetitive Forward Off State Voltage
$I_{DRM}$	Peak Forward Blocking Current
$V_{RRM}$	Peak Repetitive Reverse Off State Voltage
$I_{RRM}$	Peak Reverse Blocking Current
$V_{TM}$	Maximum On State Voltage
$I_H$	Holding Current

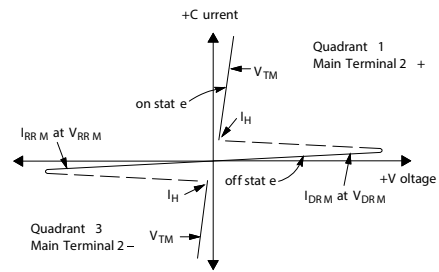
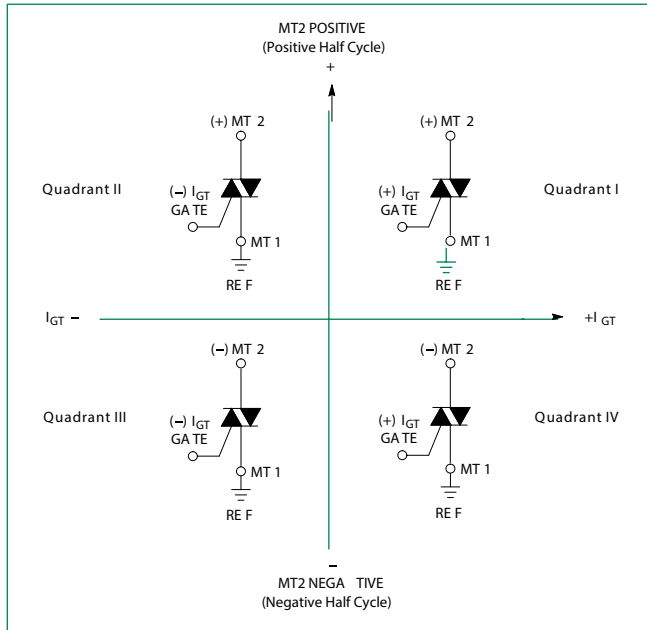

Figure 1. Current Derating

### Quadrant Definitions for a Triac



All polarities are referenced to MT1.  
With in-phase signals (using standard AC lines) quadrants I and III are used

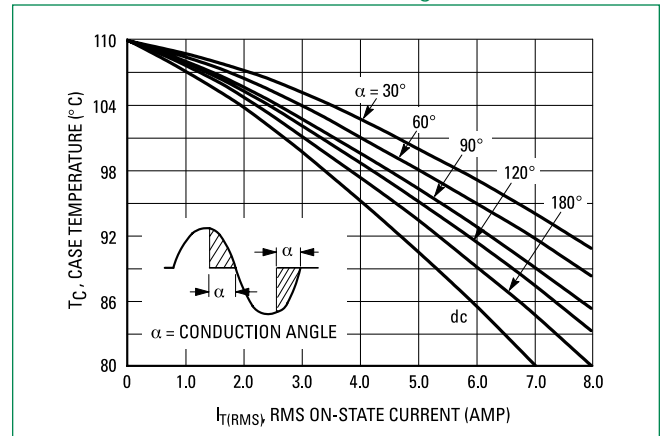
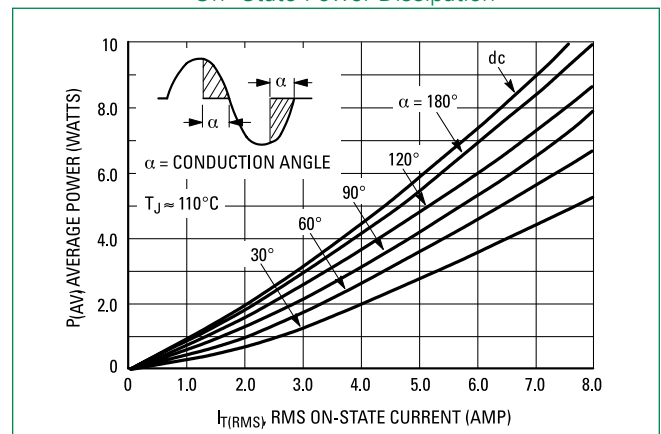

Figure 2. On-State Power Dissipation



# MAC228A

## Sensitive Gate Triacs – 400V - 800V

### Dimensions

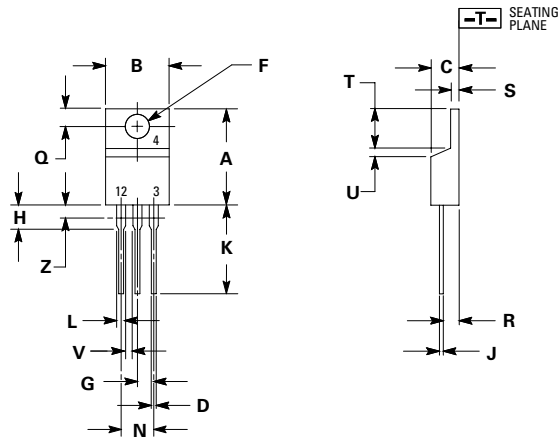

Dim	Inches		Millimeters	
	Min	Max	Min	Max
A	0.590	0.620	14.99	15.75
B	0.380	0.420	9.65	10.67
C	0.178	0.188	4.52	4.78
D	0.025	0.035	0.64	0.89
F	0.142	0.147	3.61	3.73
G	0.095	0.105	2.41	2.67
H	0.110	0.130	2.79	3.30
J	0.018	0.024	0.46	0.61
K	0.540	0.575	13.72	14.61
L	0.060	0.075	1.52	1.91
N	0.195	0.205	4.95	5.21
Q	0.105	0.115	2.67	2.92
R	0.085	0.095	2.16	2.41
S	0.045	0.060	1.14	1.52
T	0.235	0.255	5.97	6.47
U	0.000	0.050	0.00	1.27
V	0.045	---	1.15	---
Z	---	0.080	---	2.04

1. Dimensioning and tolerancing per ansi y14.5m, 1982.
2. Controlling dimension: inch.
3. Dimension z defines a zone where all body and lead irregularities are allowed.

### Part Marking System

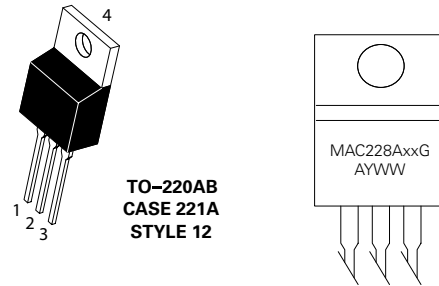

- TO-220AB  
CASE 221A  
STYLE 12
- xx = 4, 6, 8, or 10
  - A= Assembly Location (Optional)\*
  - Y= Year
  - WW = Work Week
  - G = Pb-Free Package

Pin Assignment	
1	Main Terminal 1
2	Main Terminal 2
3	Gate
4	Main Terminal 2

### Ordering Information

Device	Package	Shipping
MAC228A4G	TO-220AB (Pb-Free)	1000 Units/ Box
MAC228A6G		
MAC228A6TG		
MAC228A8G		
MAC228A8TG		
MAC228A10G		

**Disclaimer Notice** - Information furnished is believed to be accurate and reliable. However, users should independently evaluate the suitability of and test each product selected for their own applications. Littelfuse products are not designed for, and may not be used in, all applications. Read complete Disclaimer Notice at <http://www.littelfuse.com/disclaimer-electronics>.