

PRODUCT N°
SEE TABLE

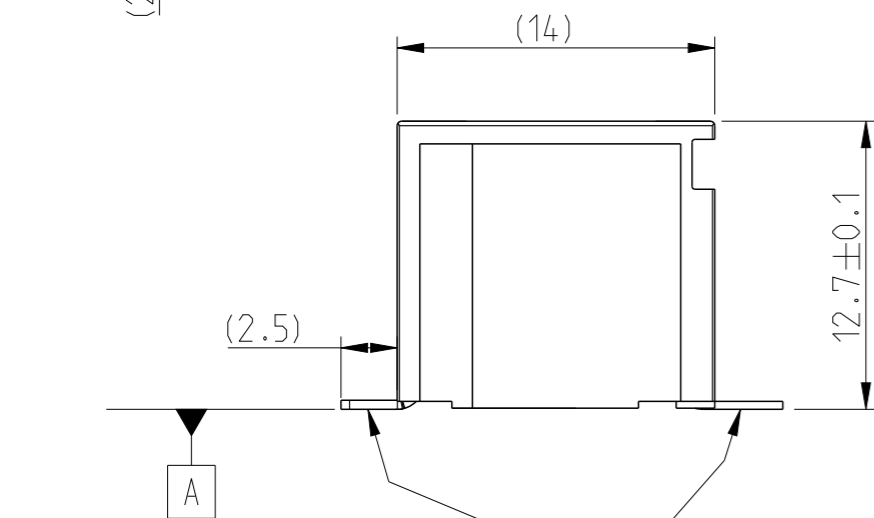

REFERENCE PLAN DEFINED BY THE BEARING SURFACE

0.1
SEE NOTE 6

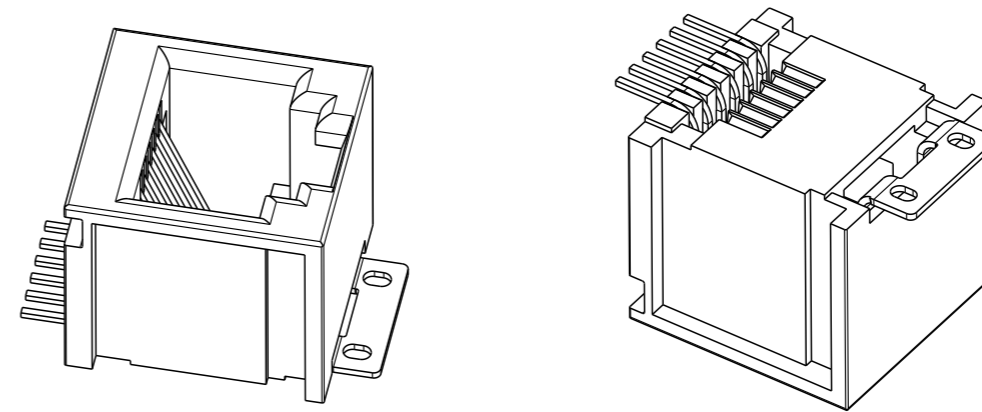
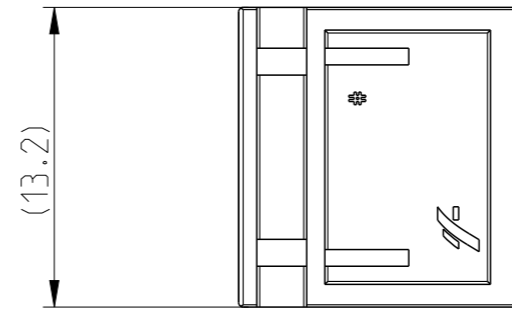
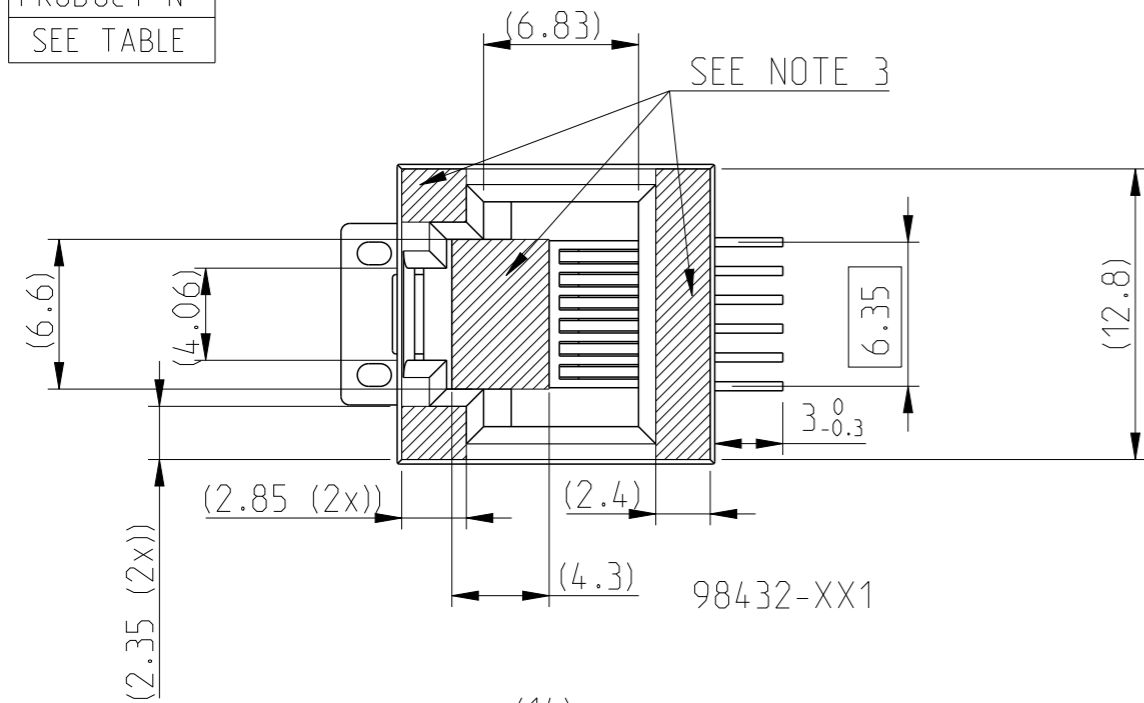
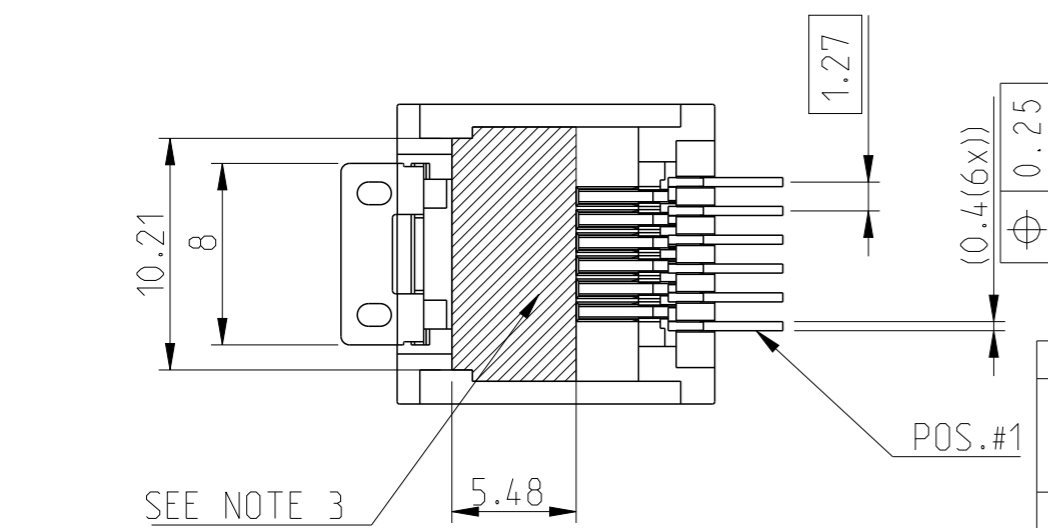
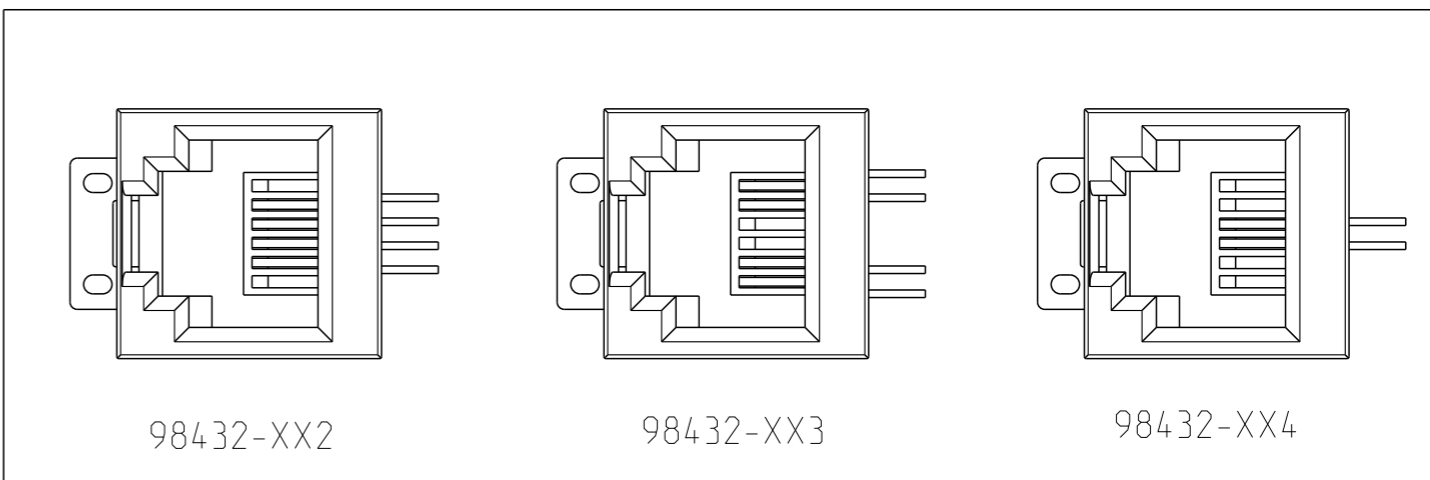

VACUUM AREA FOR 98432-X2XLF

spec ref	-	dr	Alexandre Parr	2002/09/20	projection	mm	size	A3	scale	3:1	
tolerance std	±0.13 ±2°	eng	Perrin, Emilie	2021/10/04			ecn no	ELX-F-42528-1	rel level		Released
TOLERANCES UNLESS OTHERWISE SPECIFIED		chr	-	-			product family	MODULAR JACK	rel level		Released
surface	linear	appr	Wollin, Severi	2021/10/04			title	VERTICAL SMT 6 POSITIONS		rev	W
ISO 1302	angular	0°	±Y°	www.fci.com	cat. no.	98432-XXX(LF)	Product - Customer Drw	sheet 1 of 2			

Amphenol
FCi

© 2020 Amphenol Corporation

PRODUCT N°
98432-XXXLF

CONTACT PLATING OPTION
1= GXT 0.76 μm
3= 0.76 μm GOLD
5= 1.27 μm GOLD

PACKAGE OPTIONS	VERSION	PLASTIC COLOR
TAPE AND REEL PACKAGE 1= LOADED FACE UP	TOP	BLACK
TAPE AND REEL PACKAGE 2= LOADED FACE DOWN	BOTTOM	BLACK
TAPE AND REEL PACKAGE 3= LOADED FACE UP	TOP	GREY

TERMINAL LOADING OPTIONS
1 = FULLY LOADED 6 POSITIONS
2 = ONLY POS 2,3,4,5 LOADED
3 = ONLY POS 1,2,5,6 LOADED
4 = ONLY POS 3,4 LOADED

WHEN NEEDED, SUFFIX LETTER "LF" INDICATES THE PRODUCT IS RoHS COMPATIBLE SEE NOTE 7.

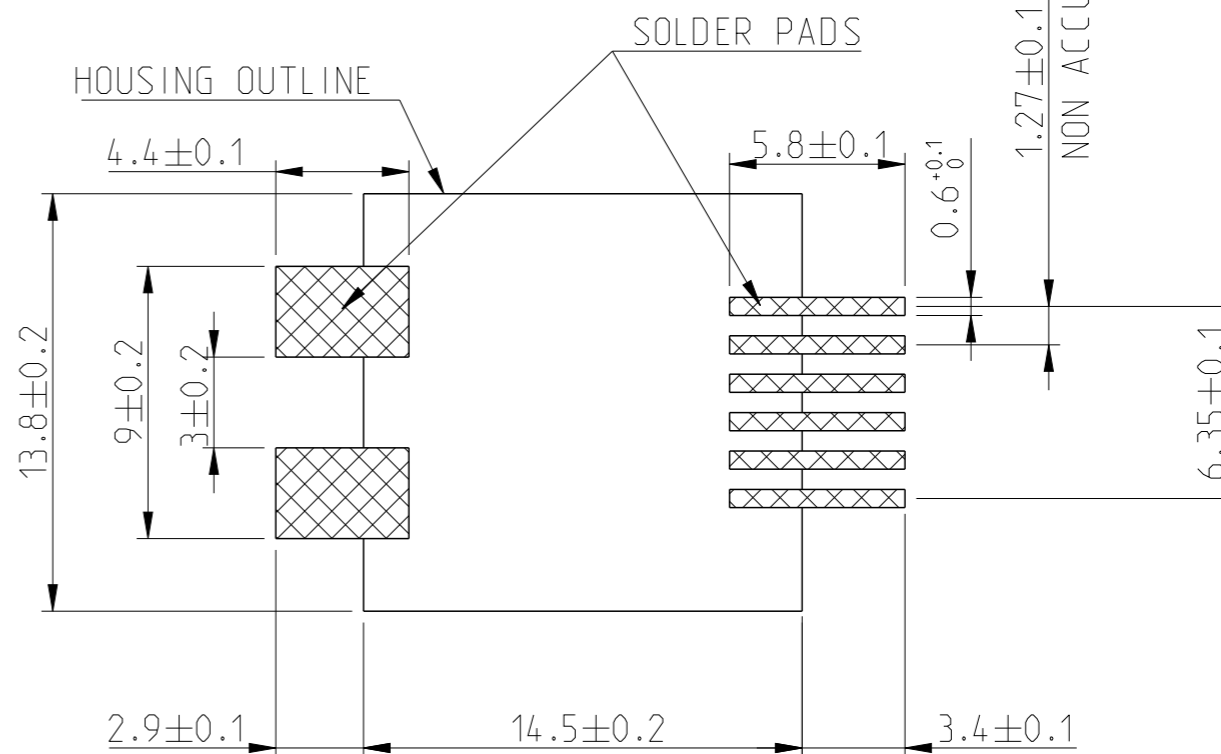
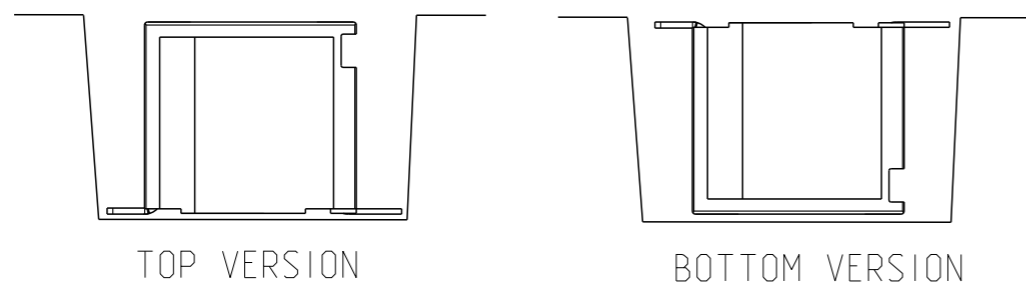

RECOMMENDED PCB FOOTPRINT

NOTES:

- 1 - MATERIAL:
HOUSING: HIGH TEMP. PLASTIC, COLOR : SEE TABLE HERE ABOVE.
- GWF1 IS 850 °C AT 1mm AND 960 °C AT 2mm THICKNESS OF THE PLATES.
- GWIT IS AT 725 °C FOR 1 AND 2 mm THICKNESS OF THE PLATES.
TERMINAL PHOSPHOR BRONZE
- 2 - PLATING
CONTACT AREA: OPTIONAL SEE TABLE
SOLDER TAIL: SnPb 90/10 2 μm MIN
NO RAW EDGES EXCEPT SOLDER TAILS TIPS
- 3 - AREA FOR VACUUM PICK AND PLACE VENTURY
- 4 - PACKAGING SPECIFICATION SEE TA 858
- 5 - DIMENSION MEASURED FROM "A" TO THE TOP OF PRODUCT
- 6 - COPLANARITY SEE TA 861.
- 7 - RoHS COMPATIBLE PRODUCT SPECIFICATIONS
- a - PLATING:
- "LF" MEANS THE PRODUCT IS LEAD-FREE,
2 μm MINIMUM MATTE TIN OVER 1.27 μm
MINIMUM NICKEL UNDERPLATE.
- b - MANUFACTURING PROCESS COMPATIBILITY:
- THE HOUSING WILL WITHSTAND EXPOSURE TO
245 °C PEAK TEMPERATURE FOR 30 SECONDS
MAX IN A CONVECTION, INFRA-RED OR VAPOR
PHASE OR REFLOW OVEN.
- c - LABELLING:
- MEETS PACKAGING SPECS AS PER GS-14-920.
- d - LEGAL STATEMENT: SEE GS-22-008

spec ref	-	dr	Alexandre Parr	2002/09/20	projection	mm	size	A3	scale	5:1	
tolerance std	±0.13 ±2°	eng	Perrin, Emilie	2021/10/04			ecn no	ELX-F-42528-1	rel level	Released	
TOLERANCES UNLESS OTHERWISE SPECIFIED		chr	-	-							
surface	linear	appr	Wollin, Severi	2021/10/04	product family	MODULAR JACK	dwg no		98432	rev	W
ISO 1302	angular			Amphenol FCI www.fci.com		VERTICAL SMT 6 POSITIONS		cat. no. 98432-XXX(LF)		Product - Customer Drw	sheet 2 of 2