

PQ1CG2032FZ/PQ1CG2032RZ

TO-220 Type Chopper Regulators

■ Features

- Maximum switching current: 3.5A
- Built-in ON/OFF control function
- Built-in soft start function to suppress overshoot of output voltage in power on sequence or ON/OFF control sequence
- Built-in oscillation circuit
(Oscillation frequency: TYP. 70kHz)
- Built-in overheat, overcurrent protection function
- TO-220 package
- Variable output voltage
(Output variable range: V_{ref} to 35V/- V_{ref} to -30V)
[Possible to select step-down output/inverting output according to external connection circuit]
- PQ1CG2032FZ: Zigzag forming
PQ1CG2032RZ: Self-stand forming

■ Applications

- Switching power supplies
- Facsimiles, printers and other OA equipment
- Battery chargers
- Personal computers and amusement equipment

■ Absolute Maximum Ratings

(Ta=25°C)

Parameter	Symbol	Rating	Unit
*1 Input voltage	V_{IN}	40	V
Error input voltage	V_{ADJ}	7	V
Input-output voltage	V_{I-O}	41	V
*2 Output - COM voltage	V_{OUT}	-1	V
*3 ON/OFF control voltage	V_C	-0.3 to +40	V
Switching current	I_{SW}	3.5	A
*4 Power dissipation	P_{D1}	1.4	W
	P_{D2}	14	W
*5 Junction temperature	T_j	150	°C
Operating temperature	T_{opr}	-20 to +80	°C
Storage temperature	T_{stg}	-40 to +150	°C
Soldering temperature	T_{sol}	260 (10s)	°C

*1 Voltage between V_{IN} terminal and COM terminal*2 Voltage between V_{OUT} terminal and COM terminal

*3 Voltage between ON/OFF control and COM terminal

*4 P_D : With infinite heat sink*5 Overheat protection may operate at $T_j=125^{\circ}\text{C}$ to 150°C

■ Outline Dimensions

(Unit : mm)

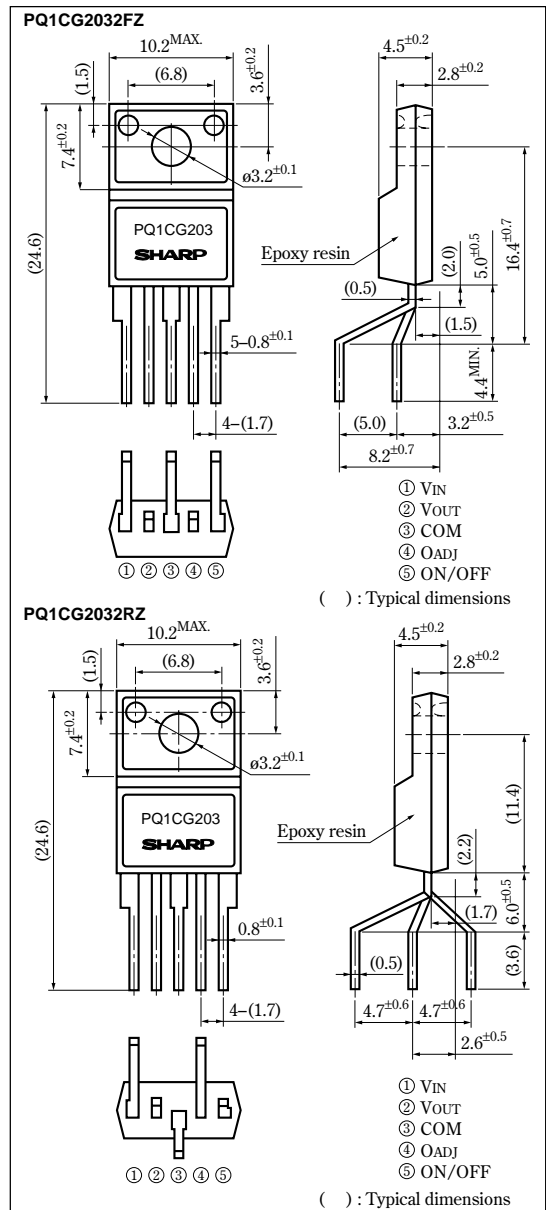

•Please refer to the chapter " Handling Precautions ".

SHARP

Electrical Characteristics

(Unless otherwise specified, condition shall be $V_{IN}=12V$, $I_o=0.2A$, $V_o=5V$, ON-OFF terminals is open, $T_a=25^\circ C$)

Parameter	Symbol	Conditions	MIN.	TYP.	MAX.	Unit
Output saturation voltage	V_{SAT}	$I_{SW}=3A$	-	1.4	1.8	V
Reference voltage	V_{ref}	-	1.235	1.26	1.285	V
Reference voltage temperature fluctuation	ΔV_{ref}	$T_j=0$ to $125^\circ C$	-	± 0.5	-	%
Load regulation	$ R_{egL} $	$I_o=0.5$ to $3A$	-	0.2	1.5	%
Line regulation	$ R_{egI} $	$V_{IN}=8$ to $35V$	-	0.5	2.5	%
Efficiency	η	$I_o=3A$	-	80	-	%
Oscillation frequency	f_o	-	60	70	80	kHz
Oscillation frequency temperature fluctuation	Δf_o	$T_j=0$ to $125^\circ C$	-	± 2	-	%
Overcurrent detecting level	I_L	-	3.6	4.2	5.8	A
Charge current	I_{CHG}	②, ④ terminals is open, ⑤ terminal	-	-10	-	μA
Input threshold voltage	V_{THL}	Duty ratio=0%, ④ terminal=0V, ⑤ terminal	-	1.3	-	V
	V_{THH}	Duty ratio=100%, ④ terminals is open, ⑤ terminal	-	2.3	-	V
ON threshold voltage	$V_{TH(ON)}$	④ terminal=0V, ⑤ terminal	0.7	0.8	0.9	V
Stand-by current	I_{SD}	$V_{IN}=40V$, ⑤ terminal=0V	-	140	400	μA
Output OFF-state dissipation current	I_{OS}	$V_{IN}=40V$, ⑤ terminal=0.9V	-	8	16	mA

Fig.1 Test Circuit

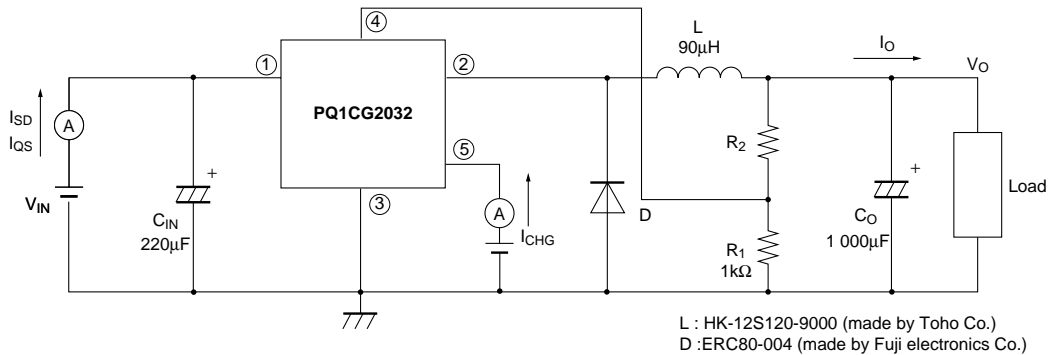
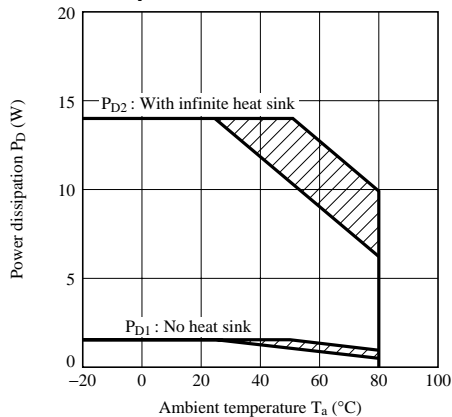

Fig.2 Power Dissipation vs. Ambient Temperature



Note) Oblique line portion: Overheat protection may operate in this area

Fig.3 Overcurrent Protection Characteristics (Typical Value)

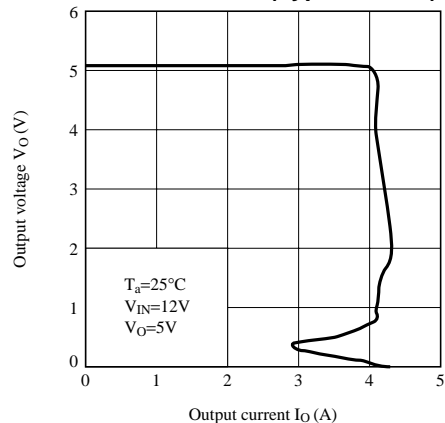

Fig.4 Efficiency vs. Input Voltage

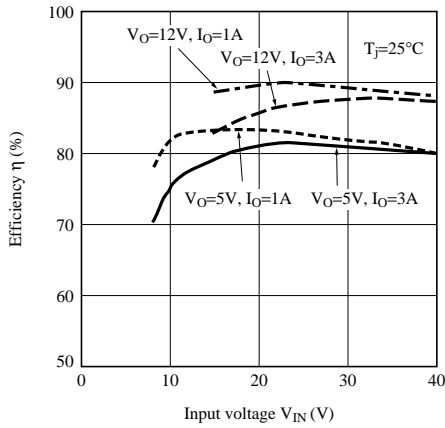

Fig.5 Output Saturation Voltage vs. Switching Current

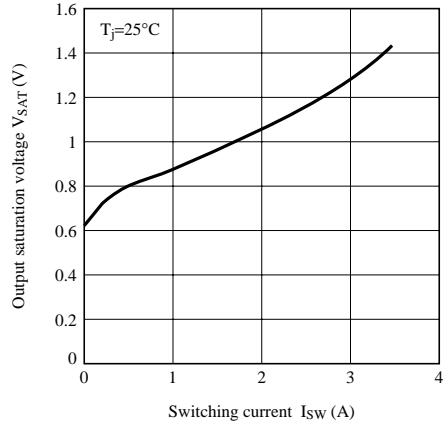

Fig.6 Stand-by Current vs. Input Voltage

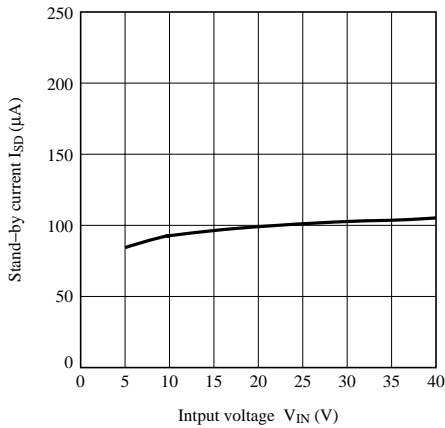

Fig.7 Reference Voltage Fluctuation vs. Junction Temperature

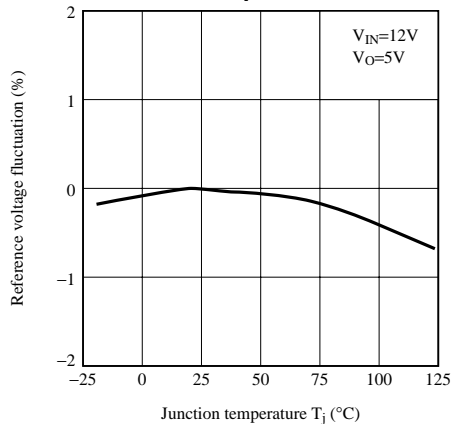

Fig.8 Load Regulation vs. Output Current

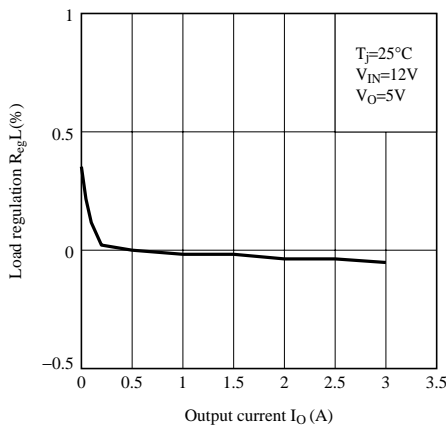

Fig.9 Line Regulation vs. Input Voltage

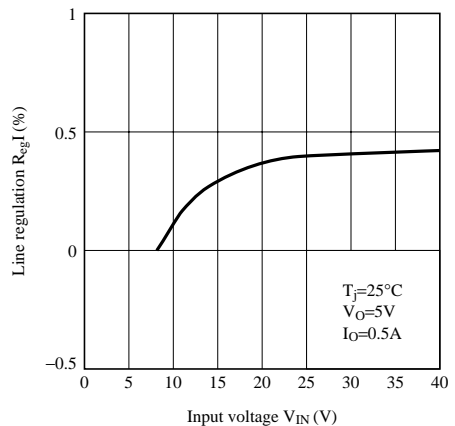

Fig.10 Oscillation Frequency Fluctuation vs. Junction Temperature

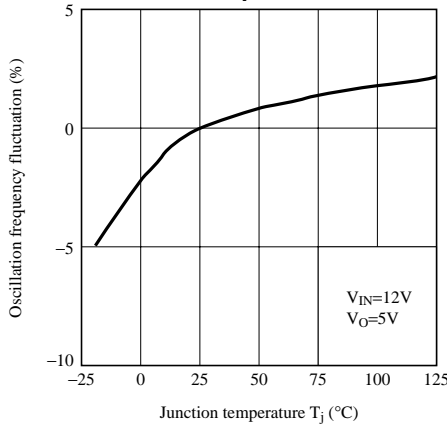

Fig.11 Overcurrent Detecting Level Fluctuation vs. Junction Temperature

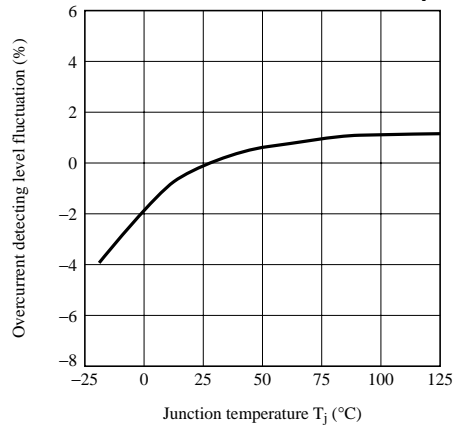

Fig.12 Threshold Voltage vs. Junction Temperature

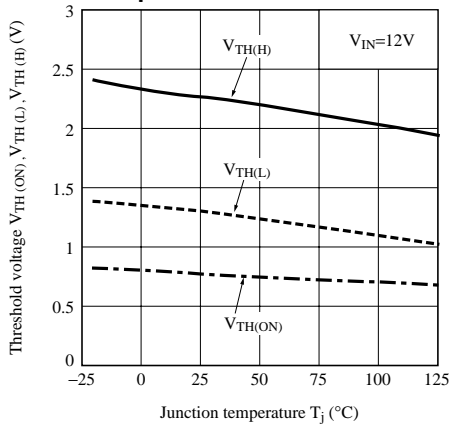

Fig.13 Operating Dissipation Current vs. Input Voltage

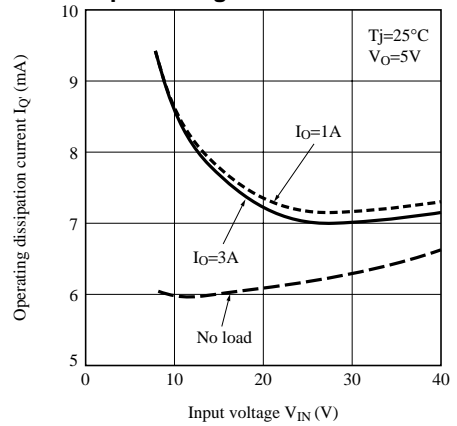

Fig.14 Block Diagram

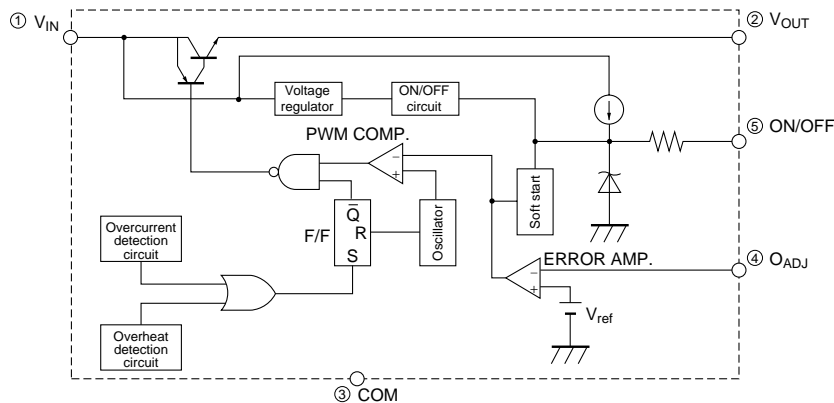

Fig.15 Step Down Type Circuit Diagram

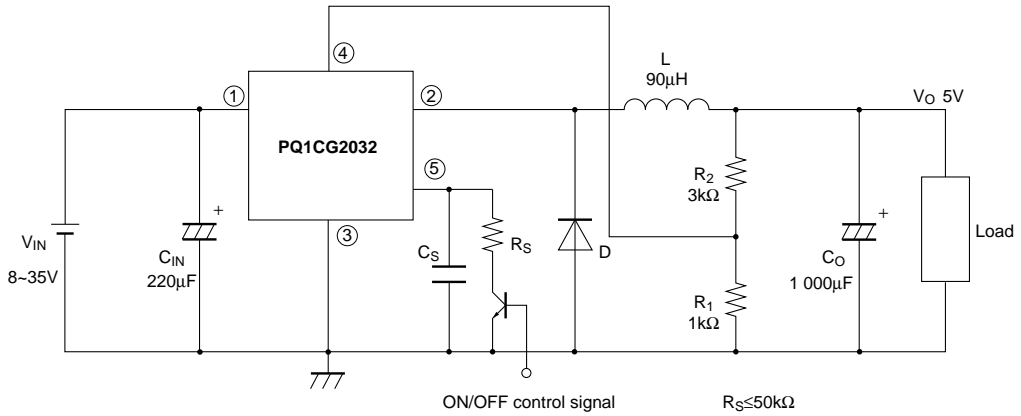
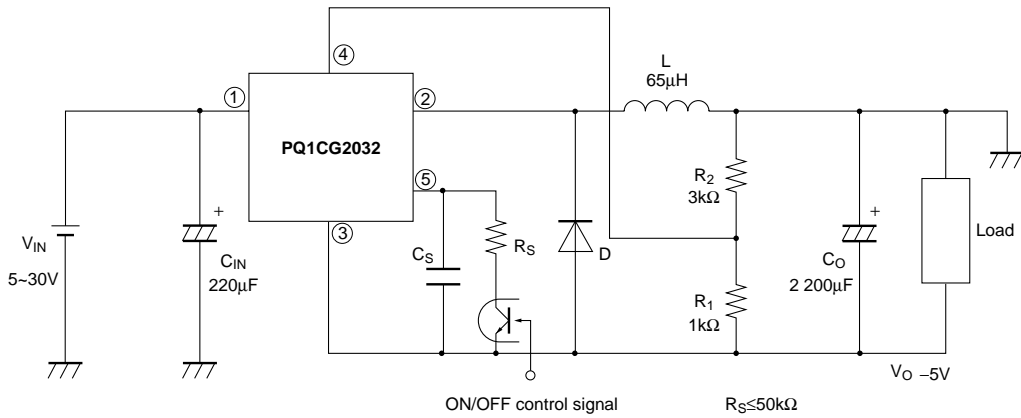

Fig.16 Polarity Inversion Type Circuit Diagram



NOTICE

- The circuit application examples in this publication are provided to explain representative applications of SHARP devices and are not intended to guarantee any circuit design or license any intellectual property rights. SHARP takes no responsibility for any problems related to any intellectual property right of a third party resulting from the use of SHARP's devices.
- Contact SHARP in order to obtain the latest device specification sheets before using any SHARP device. SHARP reserves the right to make changes in the specifications, characteristics, data, materials, structure, and other contents described herein at any time without notice in order to improve design or reliability. Manufacturing locations are also subject to change without notice.
- Observe the following points when using any devices in this publication. SHARP takes no responsibility for damage caused by improper use of the devices which does not meet the conditions and absolute maximum ratings to be used specified in the relevant specification sheet nor meet the following conditions:
 - (i) The devices in this publication are designed for use in general electronic equipment designs such as:
 - Personal computers
 - Office automation equipment
 - Telecommunication equipment [terminal]
 - Test and measurement equipment
 - Industrial control
 - Audio visual equipment
 - Consumer electronics
 - (ii) Measures such as fail-safe function and redundant design should be taken to ensure reliability and safety when SHARP devices are used for or in connection with equipment that requires higher reliability such as:
 - Transportation control and safety equipment (i.e., aircraft, trains, automobiles, etc.)
 - Traffic signals
 - Gas leakage sensor breakers
 - Alarm equipment
 - Various safety devices, etc.
 - (iii) SHARP devices shall not be used for or in connection with equipment that requires an extremely high level of reliability and safety such as:
 - Space applications
 - Telecommunication equipment [trunk lines]
 - Nuclear power control equipment
 - Medical and other life support equipment (e.g., scuba).
- Contact a SHARP representative in advance when intending to use SHARP devices for any "specific" applications other than those recommended by SHARP or when it is unclear which category mentioned above controls the intended use.
- If the SHARP devices listed in this publication fall within the scope of strategic products described in the Foreign Exchange and Foreign Trade Control Law of Japan, it is necessary to obtain approval to export such SHARP devices.
- This publication is the proprietary product of SHARP and is copyrighted, with all rights reserved. Under the copyright laws, no part of this publication may be reproduced or transmitted in any form or by any means, electronic or mechanical, for any purpose, in whole or in part, without the express written permission of SHARP. Express written permission is also required before any use of this publication may be made by a third party.
- Contact and consult with a SHARP representative if there are any questions about the contents of this publication.