



Current-Limited, High-Side P-Channel Switches with Thermal Shutdown

General Description

The MAX891L/MAX892L smart, low-voltage, P-channel, MOSFET power switches are intended for high-side load-switching applications. These switches operate with inputs from 2.7V to 5.5V, making them ideal for both 3V and 5V systems. Internal current-limiting circuitry protects the input supply against overload. Thermal-overload protection limits power dissipation and junction temperatures.

The MAX891L/MAX892L's maximum current limits are 500mA and 250mA, respectively. The current limit through the switch is programmed with a resistor from SET to ground. When the switch is on, the quiescent supply current is a low 13 μ A. When the switch is off, the quiescent current decreases to 0.1 μ A.

The MAX891L/MAX892L are available in 8-pin μ MAX packages.

Applications

PCMCIA Slots
Access Bus Slots
Portable Equipment

Features

- ◆ Ultra-Small μ MAX Package—Only 1.11mm High
- ◆ 2.7V to 5.5V Input Range
- ◆ Programmable Current Limit
- ◆ Low 13 μ A Quiescent Current at $V_{IN} = 3.3V$, 0.1 μ A Switch Off
- ◆ Thermal Shutdown
- ◆ FAULT Indicator Output
- ◆ On-Resistances:
0.12 Ω (MAX891L)
0.25 Ω (MAX892L)

Ordering Information

PART	TEMP. RANGE	PIN-PACKAGE	CURRENT LIMIT
MAX891LC/D	0°C to +70°C	Dice**	500mA
MAX891LEUA*	-40°C to +85°C	8 μ MAX	500mA
MAX892LC/D	0°C to +70°C	Dice**	250mA
MAX892LEUA*	-40°C to +85°C	8 μ MAX	250mA

* To order these units in tape and reel, add (-T) to the end of the part number.

** Dice are tested at $T_A = +25^\circ\text{C}$.

Typical Operating Circuit

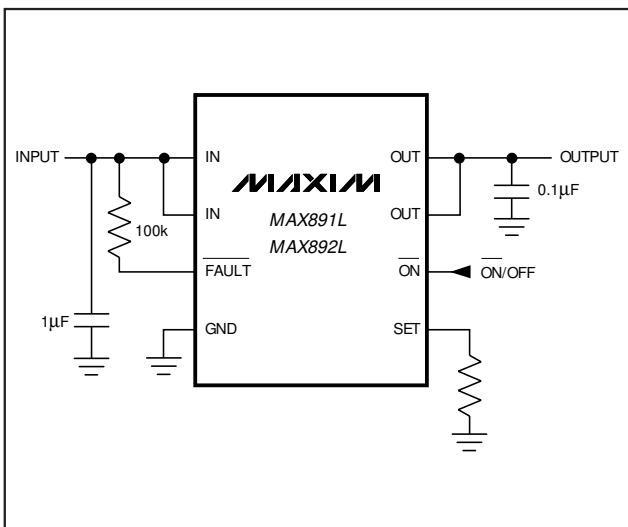

Pin Configuration

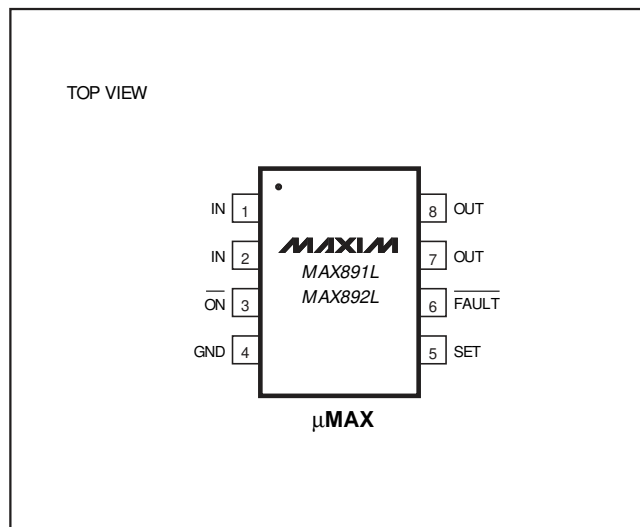

Current-Limited, High-Side P-Channel Switches with Thermal Shutdown

ABSOLUTE MAXIMUM RATINGS

IN to GND	-0.3V to 6V	Continuous Power Dissipation ($T_A = +70^\circ\text{C}$)	
$\overline{\text{ON}}$, FAULT to GND.....	-0.3V to 6V	μMAX (derate 4.1mW/ $^\circ\text{C}$ above $+70^\circ\text{C}$)	330mW
SET, OUT to GND	-0.3V to ($V_{\text{IN}} + 0.3\text{V}$)	Operating Temperature Range	
Maximum Continuous Switch Current		MAX891LEUA/MAX892LEUA	-40 $^\circ\text{C}$ to +85 $^\circ\text{C}$
MAX891L	0.75A	Storage Temperature Range	-65 $^\circ\text{C}$ to +150 $^\circ\text{C}$
MAX892L	0.375A	Lead Temperature (soldering, 10sec)	+300 $^\circ\text{C}$

Stresses beyond those listed under "Absolute Maximum Ratings" may cause permanent damage to the device. These are stress ratings only, and functional operation of the device at these or any other conditions beyond those indicated in the operational sections of the specifications is not implied. Exposure to absolute maximum rating conditions for extended periods may affect device reliability.

ELECTRICAL CHARACTERISTICS

($V_{\text{IN}} = 3\text{V}$, $T_A = 0^\circ\text{C}$ to $+85^\circ\text{C}$, unless otherwise noted. Typical values are at $T_A = +25^\circ\text{C}$.)

PARAMETER	CONDITIONS	MIN	TYP	MAX	UNITS	
Operating Voltage		2.7		5.5	V	
Quiescent Current	$V_{\text{IN}} = 5\text{V}$, $\overline{\text{ON}} = \text{GND}$, $I_{\text{OUT}} = 0\text{mA}$		13	20	μA	
Off-Supply Current	$\overline{\text{ON}} = \text{IN}$, $V_{\text{IN}} = V_{\text{OUT}} = 5.5\text{V}$		0.02	1	μA	
Off-Switch Current	$\overline{\text{ON}} = \text{IN}$, $V_{\text{IN}} = 5.5\text{V}$, $V_{\text{OUT}} = 0\text{V}$		0.02	3	μA	
Undervoltage Lockout	Rising edge, 1% hysteresis	2.0	2.3	2.6	V	
On-Resistance	$V_{\text{IN}} = 4.5\text{V}$	MAX891L	120	225	$\text{m}\Omega$	
		MAX892L	250	420		
	$V_{\text{IN}} = 3.0\text{V}$	MAX891L	150	300	$\text{m}\Omega$	
		MAX892L	300	500		
Current-Limit-Amplifier Accuracy	V_{SET} required to turn the switch off (Note 1)	1.178	1.240	1.302	V	
Maximum Output Current	MAX891L		500		mA	
	MAX892L		250			
I_{OUT} to I_{SET} Current Ratio	$V_{\text{OUT}} = 1.6\text{V}$ to 2.8V	MAX891L, $I_{\text{OUT}} = 250\text{mA}$	840	965	1130	A/A
		MAX892L, $I_{\text{OUT}} = 125\text{mA}$	840	965	1130	
$\overline{\text{ON}}$ Input Low Voltage	$V_{\text{IN}} = 2.7\text{V}$ to 5.5V			0.8	V	
$\overline{\text{ON}}$ Input High Voltage	$V_{\text{IN}} = 2.7\text{V}$ to 3.6V	2.0			V	
	$V_{\text{IN}} = 4.5\text{V}$ to 5.5V	2.4				
$\overline{\text{ON}}$ Input Leakage	$V_{\overline{\text{ON}}} = 5.5\text{V}$	-1	0.01	1	μA	
I_{SET} Bias Current	$V_{\text{SET}} = 1.24\text{V}$, $I_{\text{OUT}} = 0\text{mA}$		0.5	3	μA	
$\overline{\text{FAULT}}$ Logic Output Low Voltage	$I_{\text{SINK}} = 1\text{mA}$, $V_{\text{SET}} = 1.4\text{V}$			0.4	V	
$\overline{\text{FAULT}}$ Logic Output High Leakage	$V_{\overline{\text{FAULT}}} = 5.5\text{V}$, $V_{\text{SET}} = 1\text{V}$		0.05	1	μA	
Slow-Current-Loop Response Time	20% current overdrive, $V_{\text{IN}} = 5\text{V}$		5		μs	
Fast-Current-Loop Response Time			2		μs	
Turn-On Time	$I_{\text{OUT}} = 250\text{mA}$ (MAX891L), or 125mA (MAX892L)	$V_{\text{IN}} = 5\text{V}$	100	200	μs	
		$V_{\text{IN}} = 3\text{V}$	150			
Turn-Off Time	$V_{\text{IN}} = 5\text{V}$	0.8	2	20	μs	

Current-Limited, High-Side P-Channel Switches with Thermal Shutdown

MAX891L/MAX892L

ELECTRICAL CHARACTERISTICS

($V_{IN} = 3V$, $T_A = -40^{\circ}C$ to $+85^{\circ}C$, unless otherwise noted.) (Note 2)

PARAMETER	CONDITIONS	MIN	TYP	MAX	UNITS
Operating Voltage		3.0		5.5	V
Quiescent Current	$V_{IN} = 5V$, $\overline{ON} = GND$, $I_{OUT} = 0mA$			50	μA
Off-Supply Current	$\overline{ON} = IN$, $V_{IN} = V_{OUT} = 5.5V$			2.2	μA
Off-Switch Current	$\overline{ON} = IN$, $V_{IN} = 5.5V$, $V_{OUT} = 0V$			8	μA
Undervoltage Lockout	Rising edge, 1% hysteresis	2.0		2.9	V
On-Resistance	$V_{IN} = 4.5V$	MAX891L		225	$m\Omega$
		MAX892L		420	
	$V_{IN} = 3.0V$	MAX891L		300	$m\Omega$
		MAX892L		500	
Current-Limit-Amplifier Accuracy	V_{SET} required to turn the switch off (Note 1)	1.14		1.34	V
I_{OUT} to I_{SET} Current Ratio	$V_{OUT} = 1.6V$ to $2.8V$	MAX891L, $I_{OUT} = 250mA$	805	1210	A/A
		MAX892L, $I_{OUT} = 125mA$	805	1210	
\overline{FAULT} Logic Output Low Voltage	$I_{SINK} = 1mA$, $V_{SET} = 1.4V$			0.4	V
Turn-On Time	$V_{IN} = 5V$			200	μs
Turn-Off Time	$V_{IN} = 5V$	0.25		20	μs

Note 1: Tested with $I_{OUT} = 50mA$ for the MAX891L, 25mA for the MAX892L, and V_{SET} raised until $V_{IN} - V_{OUT} \geq 0.8V$.

Note 2: Parameters to $-40^{\circ}C$ are guaranteed by design, not production tested.

Current-Limited, High-Side P-Channel Switches with Thermal Shutdown

Typical Operating Characteristics

(Typical Operating Circuit, $T_A = +25^\circ\text{C}$, unless otherwise noted.)

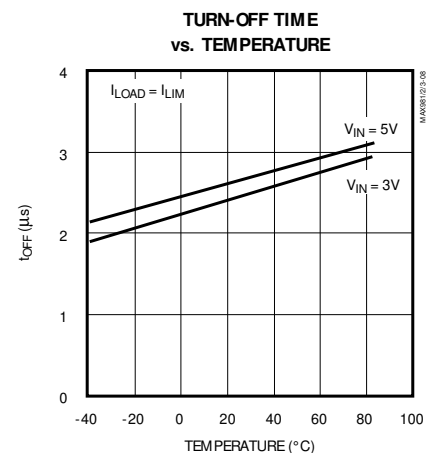
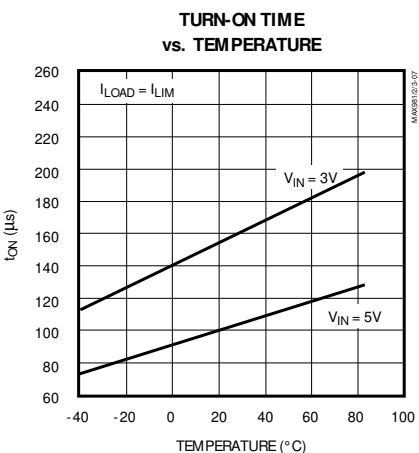
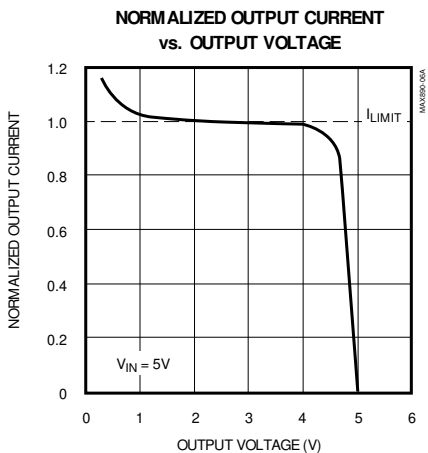
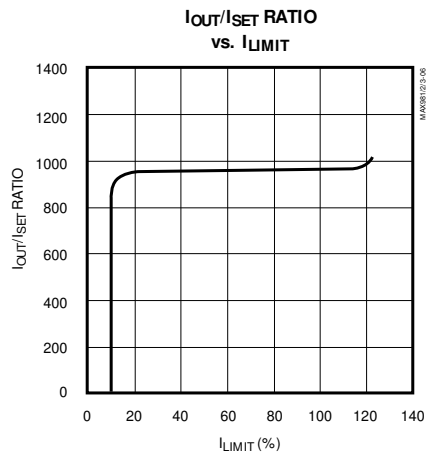
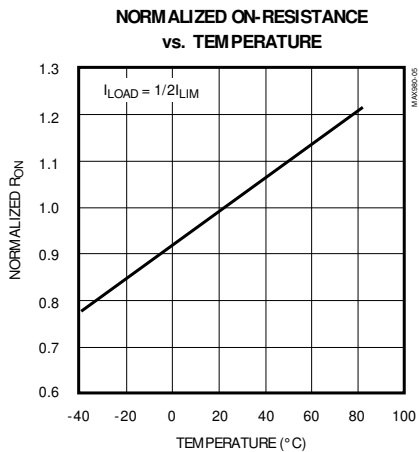
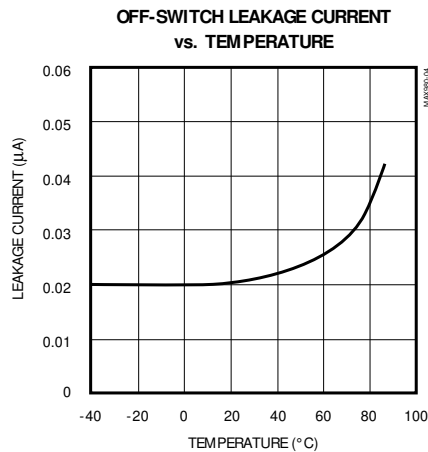
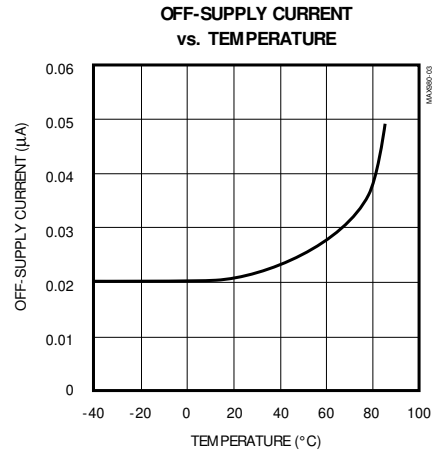
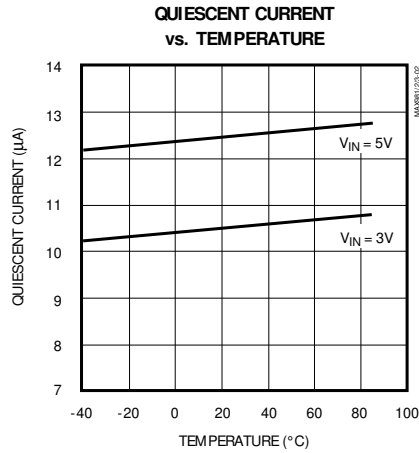
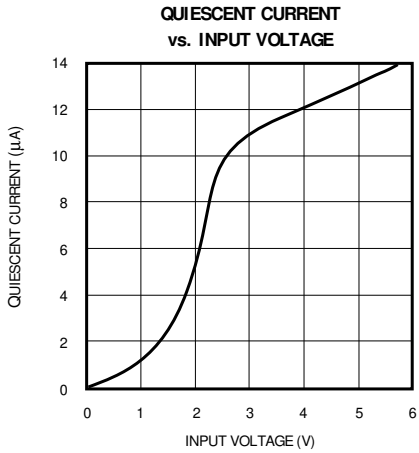

Current-Limited, High-Side P-Channel Switches with Thermal Shutdown

Typical Operating Characteristics (continued)

(Typical Operating Circuit, $T_A = +25^\circ\text{C}$, unless otherwise noted.)

CURRENT-LIMIT RESPONSE
(MAX891L, $R_L = 0.8\Omega$)

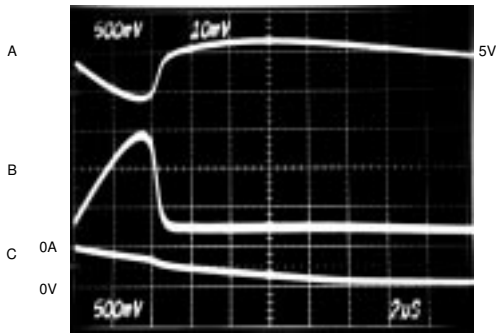

$C_{IN} = 47\mu\text{F}$, $C_{OUT} = 0.1\mu\text{F}$
A: V_{IN} , 500mV/div, AC COUPLED
B: I_{OUT} , 2A/div
C: V_{OUT} , 5V/div

CURRENT-LIMIT RESPONSE
(MAX891L, $R_L = 0.5\Omega$)

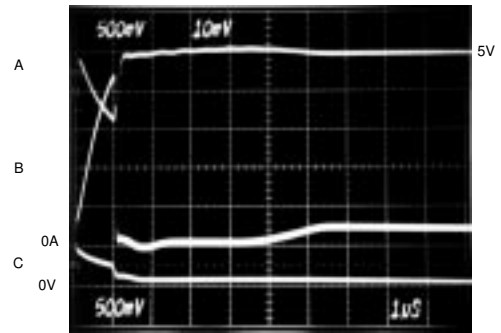

$C_{IN} = 47\mu\text{F}$, $C_{OUT} = 0.1\mu\text{F}$
A: V_{IN} , 500mV/div, AC COUPLED
B: I_{OUT} , 2A/div
C: V_{OUT} , 5V/div

SWITCH TURN-ON TIME

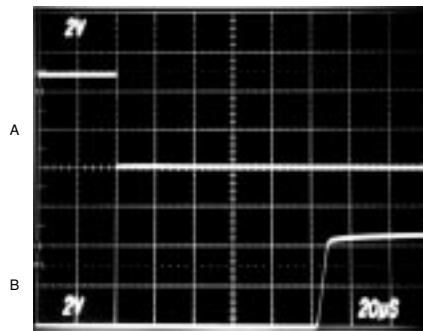

$V_{IN} = 5\text{V}$, $I_{OUT} = I_{LIM}$
A: V_{ON} , 2V/div
B: V_{OUT} , 2V/div

SWITCH TURN-OFF TIME

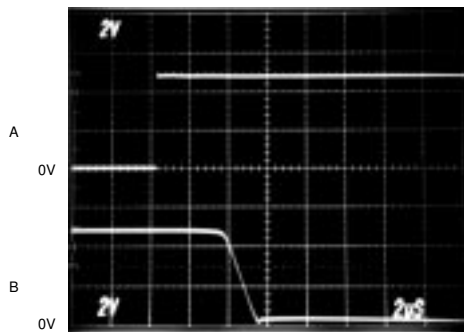

$V_{IN} = 5\text{V}$, $I_{OUT} = I_{LIM}$
A: V_{ON} , 2V/div
B: V_{OUT} , 2V/div

SWITCH TIMING CHARACTERISTICS

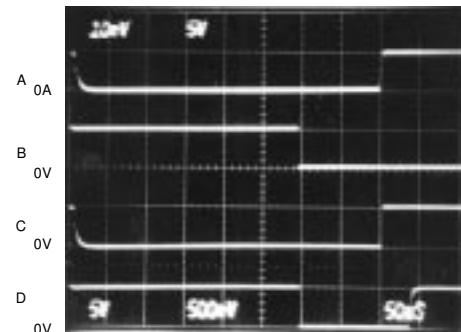

$V_{IN} = 5\text{V}$
A: I_{LOAD} , 0.1A/div
B: V_{ON} , 5V/div
C: V_{OUT} , 5V/div
D: V_{FAULT} , 5V/div

MAX891L/MAX892L

Current-Limited, High-Side P-Channel Switches with Thermal Shutdown

MAX891L/MAX892L

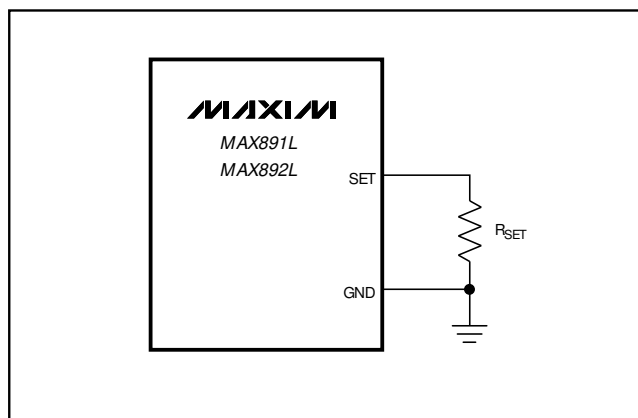

Figure 2. Setting the Current Limit

Thermal Shutdown

The MAX891L/MAX892L feature thermal shutdown. The switch turns off when the junction temperature exceeds +135°C. Once the device cools by 10°C, the switch turns back on. If the fault short-circuit condition is not removed, the switch will cycle on and off, resulting in a pulsed output.

Fault Indicator

The MAX891L/MAX892L provide a fault output ($\overline{\text{FAULT}}$). This open-drain output goes low when in current limit or when the die temperature exceeds +135°C. During start-up, $\overline{\text{FAULT}}$ is low until the switch is fully on and no over-current condition exists. A 100k Ω pull-up resistor from $\overline{\text{FAULT}}$ to IN provides a logic-control signal.

Applications Information

Input Capacitor

To limit input voltage drop during momentary output short-circuit conditions, connect a capacitor from IN to GND. A 1 μF ceramic capacitor is adequate for most applications; however, higher capacitor values further reduce voltage drop at the input.

Output Capacitor

Connect a 0.1 μF capacitor from OUT to GND. One function of this capacitor is to prevent inductive parasitics from pulling OUT negative during turn-off.

Layout and Thermal-Dissipation Consideration

To take full advantage of the switch-response time to output short-circuit conditions, it is very important to keep all traces as short as possible to reduce the effect of undesirable parasitic inductance. Place input and output capacitors as close as possible to the device (no more than 5mm).

Under normal operating conditions, the package dissipates and channels heat away. Calculate maximum power as follows:

$$P = I_{\text{LIM}}^2 \times R_{\text{ON}}$$

where R_{ON} is the on-resistance of the switch.

When the output is short circuited, voltage drop across the switch equals the input supply. Hence, the power dissipated across the switch increases, as does the die temperature. If the fault condition is not removed, the thermal-overload-protection circuitry turns the switch off until the die temperature falls by 10°C. A ground plane in contact with the device helps dissipate additional heat.

Chip Information

TRANSISTOR COUNT: 396

SUBSTRATE CONNECTED TO GND

Current-Limited, High-Side P-Channel Switches with Thermal Shutdown

Tape-and-Reel Information

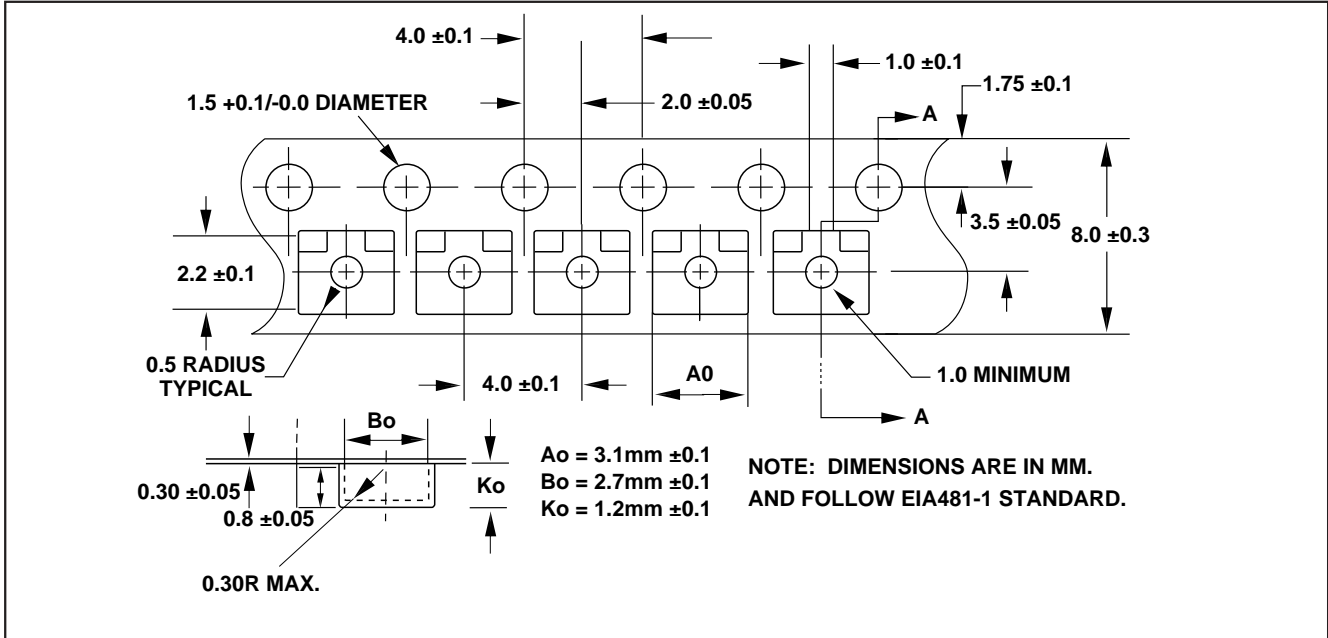

Package Information

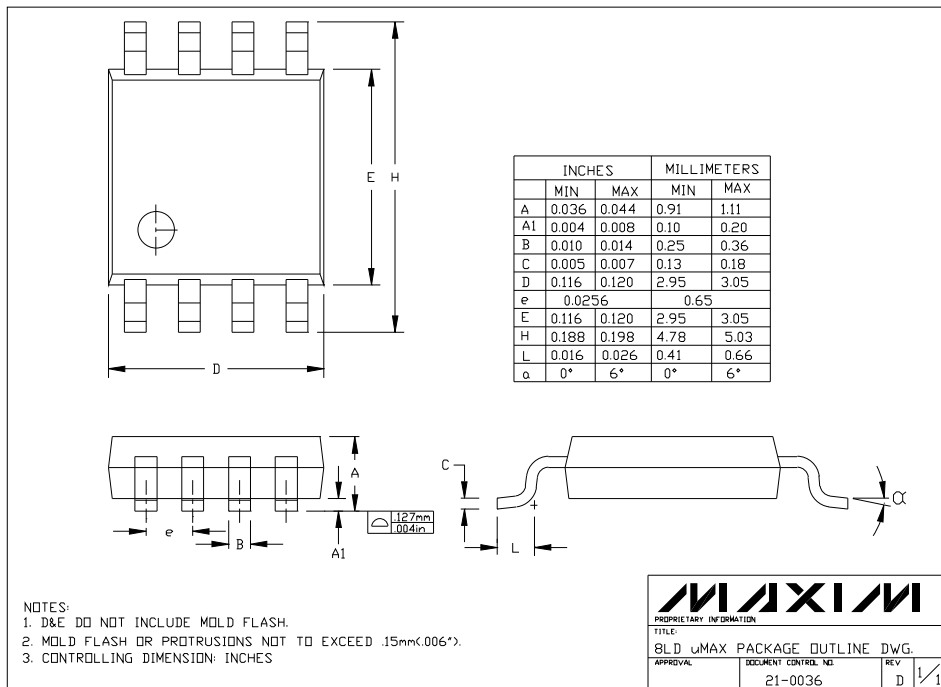

Maxim cannot assume responsibility for use of any circuitry other than circuitry entirely embodied in a Maxim product. No circuit patent licenses are implied. Maxim reserves the right to change the circuitry and specifications without notice at any time.

8 Maxim Integrated Products, 120 San Gabriel Drive, Sunnyvale, CA 94086 (408) 737-7600