

PCM270xEVM-U

This user's guide contains information on the setup, operation, and construction of the PCM270xEVM-U, an evaluation module (EVM) for digital-to-analog converters (DACs) PCM2704 and PCM2705.

Contents

1	Description	1
1.1	Related Documentation From Texas Instruments	1
1.2	Block Diagram	2
1.3	Basic Operating Connections	2
2	Schematic, BOM, and Printed-Circuit Board	4
2.1	PCM270xEVM-U Schematic	4
2.2	PCM270xEVM-U Parts List (BOM)	5
2.3	PCM270xEVM-U Printed-Circuit Board	6

List of Figures

1	PCM270xEVM-U Block Diagram.....	2
2	PCM270xEVM-U Circuit Diagram	4
3	PCM270xEVM-U Silkscreen.....	6
4	PCM270xEVM-U—Top View	6
5	PCM270xEVM-U—Bottom View	7

List of Tables

1	Bill of Materials	5
---	-------------------------	---

1 Description

The PCM270xEVM-U is an evaluation board for the USB interface DACs PCM2704 (DEM-PCM2704) and PCM2705 (DEM-PCM2705).

A USB connector is mounted on the PCM270xEVM-U. This connector allows a customer to evaluate DAC performance by connecting a USB interface to it.

By the use of jumper settings on the board, the PCM270xEVM-U can be operated either from USB bus power or from an external 5-V power supply.

The PCM270xEVM-U outputs a stereo audio signal for headphones at stereo minijack CN2 (PD = 12 mW at $R_L = 32 \Omega$), and an S/PDIF digital interface output at optical Toslink™ connector U4.

The PCM270xEVM-U is fully compliant with the USB 1.1 specification with full-speed transceiver format.

1.1 Related Documentation From Texas Instruments

PCM2704, PCM2705, PCM2706, PCM2707 Stereo Audio DAC With USB Interface, Single-Ended Headphone Output and S/PDIF Output data sheet ([SLES081](#))

1.2 Block Diagram

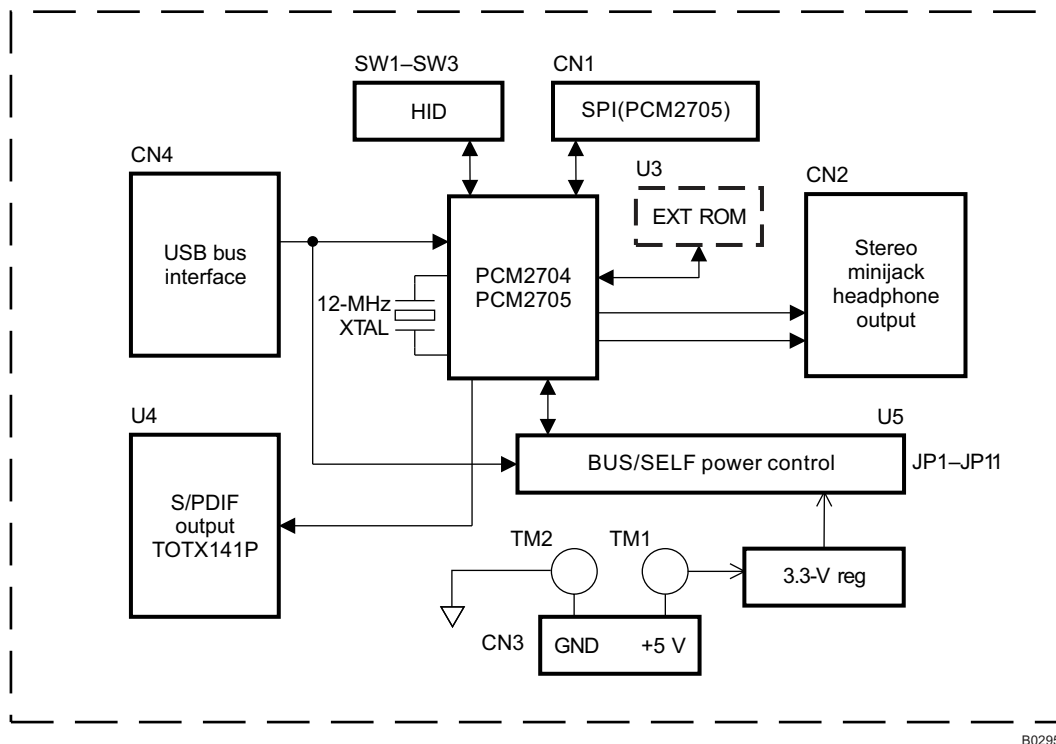

Figure 1. PCM270xEVM-U Block Diagram

1.3 Basic Operating Connections

1.3.1 Universal Serial Bus (USB)

A USB interface is connected to USB connector CN4.

1.3.2 Stereo Headphone Output

A stereo headphone plug is connected to stereo minijack audio output connector CN2.

1.3.3 Bus-Power/Self-Power Selection

Operation in the bus-powered or self-powered mode is user selectable, chosen by jumper plug settings on the board. The default setting is self-powered operation.

Bus-Powered

JP1, (JP7): Shorting plug of jumper JP1 must be connected. (JP7 can be removed if the application draws less than 100 mA.)

JP2–JP6, JP8: Shorting plugs of jumpers JP2–JP6, JP8 must be removed.

JP9, JP10, JP11: Shorting plugs of jumpers JP9, JP10, and JP11 must be connected on the BUS side.

CN3 or TM1, TM2 external power supply:

External 5-V power supply must not be connected.

Self-Powered (default setting)

JP1: Shorting plug of jumper JP1 must be removed.

JP2–JP8: Shorting plugs of jumpers JP2–JP8 must be connected.

JP9, JP10, JP11: Shorting plugs of jumpers JP9, JP10, and JP11 must be connected on the SELF side.

CN3 or TM1, TM2 external power supply:

External power supply must be connected either to CN3 or to TM1 and TM2. ($V_{CC} = 4.5\text{ V to }10\text{ V}$. $I_{CC} = 30\text{ mA typical, }70\text{ mA maximum}$.) A 3.3-V regulator IC is mounted to provide a 3.3-V power supply for PCM2704/2705 and logic circuitry on the board from the external power supply.

In the case of self-powered operation, device is enabled when the USB interface is connected and HOST is set to High.

1.3.4 SPI Interface (PCM2705)

An SPI interface (MS, MC, MD) for operational control of the PCM2705 can be connected at CN1.

1.3.5 Suspend

Suspend status is indicated at the SSPND pin of CN1.

1.3.6 S/PDIF Output

USB audio data input to the PCM2704/2705 is output in S/PDIF format. This electrical output is sent to U4, which converts the S/PDIF signal into light for optical transmission.

2 Schematic, BOM, and Printed-Circuit Board

This chapter presents the PCM270xEVM-U printed-circuit board and schematic.

2.1 PCM270xEVM-U Schematic

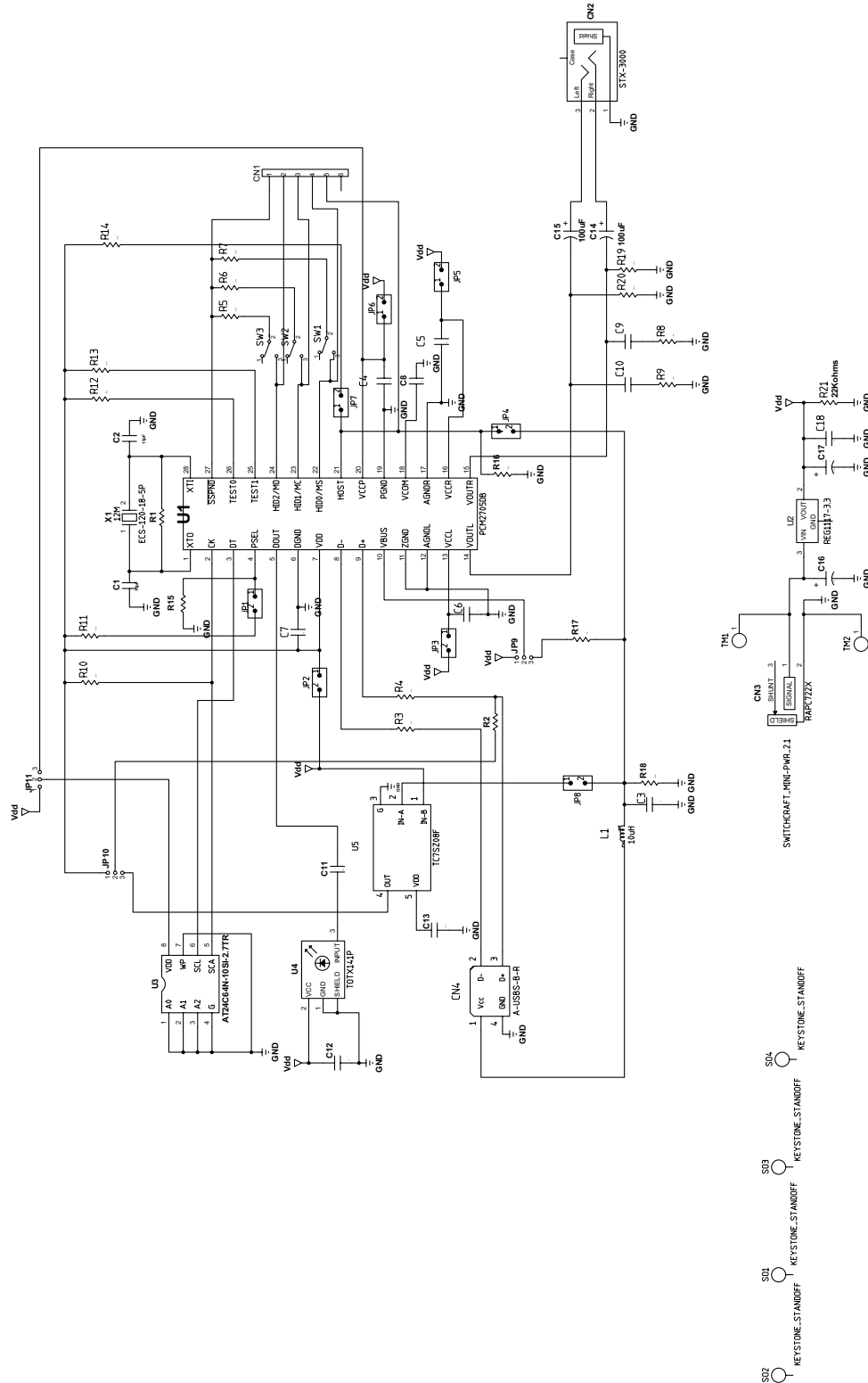

Figure 2. PCM270xEVM-U Circuit Diagram

2.2 PCM270xEVM-U Parts List (BOM)

Table 1. Bill of Materials

Item	QTY	MFG	MFG Part#	REF DES	Description	Value or Function
	REF	–	PCM2704/2705 EVMA	–	ASSEMBLY	–
	REF	–	PCM2704/2705 EVMA	–	SCHEMATIC	–
	1	One Source Group	PCM2704/2705 EVMA	–	FABRICATION	–
	REF	–	PCM2704/2705 EVMA	–	ARTWORK	–
1	4		2031	SO1, SO2, SO3, SO4		STANDOFF,4-40,1.0INx3/16IN,ALUM RND F-F
2	3		26630301RP2	JP9, JP10, JP11		HEADER 3 PIN, PCB 2.0MM ROHS
3	1		26630601RP2	CN1		HEADER 6 PIN, PCB 2.0MM ROHS
4	1		RAPC722X	CN3		JACK MINI-PWR THRU-RA 2,1ID/5.5OD 5A ROHS
5	1		STX-3000	CN2		JACK,MINI-STEREO,ROHS
6	1		TC7SZ08F	U5		2-Input AND Gate
7	1		TOTX141P	U4		TOSLINK TRANSMITTER 3.3V 15MB SHUTTER ROHS
8	6		GRM185R61A105KE36D	C3, C4, C5, C6, C7, C12	603	CAP SMD0603 CERM 1.0UFD 10V 10% X5R ROHS
9	1		GRM21BR71A106KE51L-VSA	C8	805	CAP SMD0805 CERM 10UFD 10V10% X7R ROHS
10	1		3750-0	TM2	Black	BINDING POST, BLACK 60V/15A GOLD ROHS
11	1	PANASONIC	ECQ-B1H104JF	C18	CAP,RAD,POLY	CAP,THU,POLYES-FILM,0.1µF,50V,5%,85C
12	2	MURATA	GRM39X7R223K16V	C9, C10	CAP,SMT,0603	CAPACITOR,SMT,0603,CERAMIC,16V,10%,.022µF
13	2	MURATA	GRM40COG150J50V	C1, C2	CAP,SMT,0805	50V,±5%,15pF
14	2	MURATA	GRM40X7R103K50V	C11, C13	CAP,SMT,0805	50V,10%,.010µF
15	2	PANASONIC	EEVFC0J101P	C14, C15	CAPACITOR,SMT,ELEC	CAPACITOR,SMT,ELEC,100uF,6.3V,20%, -40-105°C
16	1	ASSMANN ELEC	A-USBS-B-R	CN4	CONNECTOR,THU,4P	CONNECTOR,THU,4P,USB RECEPTACLE,TYPE B, PCB MOUNT
17	1	ECS	ECS-120-18-5P	X1	CRYSTAL,SMT,2P	XTL,SMT,12.000MHz,18pF,Fund,50ppm,-10-70°C
18	3		G12AP-RO	SW1, SW2, SW3	G12AP	SWITCH THRU SPDT STRAIGHT ULTRA MINIATURE ROHS
19	8	SAMTEC	TSW-101-07-G-D	JP1, JP2, JP3, JP4, JP5, JP6, JP7, JP8	HEADER,THU	HEADER,THU,2P,2X1,MALE,DUAL ROW,100LS,100TL
20	1	ATMEL	AT24C64N-10SI-2.7TR	U3	IC,SMT,8P	2 WIRE SERIAL EEPROM
21	1	PANASONIC	ELJFA100KJ/F	L1	INDUCTOR,SMT	10.0µH
22	2		ECA1CM100	C16, C17	M	CAP ALUM ELEC M RADIAL 10UFD 16V 20% ROHS
23	2	VISHAY	CRCW08051002F	R19, R20	RES,SMT,0805	RESISTOR,SMT,0805,THICK FILM,1%,1/8W,10.0K
24	3	VISHAY	CRCW08051004F	R1, R15, R16	RES,SMT,0805	RESISTER,SMT,0805,THICK FILM,1%,1/8W,1.00M
25	1	VISHAY	CRCW080510R0F	R17	RES,SMT,0805	RESISTER,SMT,0805,THICK FILM,1%,1/8W,10.0 Ω
26	9	VISHAY	CRCW08051501F	R2, R5, R6, R7, R10, R11, R12, R13, R14	RES,SMT,0805	RESISTER,SMT,0805,THICK FILM,1%,1/8W,1.50K
27	1	PANASONIC	ERJ-6GEYJ106V	R18	RES,SMT,0805	RESISTOR,SMT,0805,THICK FILM,10M,5%,1/8W
28	2	PANASONIC	ERJ-6GEYJ160V	R8, R9	RES,SMT,0805	RESISTOR,SMT,0805,THICK FILM,5%,1/8W,16
29	2	PANASONIC	ERJ-6GEYJ270V	R3, R4	RES,SMT,0805	RESISTOR,SMT,0805,THICK FILM,5%,1/8W,27
30	1	PANASONIC	ERA-6YEB223V	R21	RES,SMT,2P	RESISTOR,SMT,0805,22K,0.1%,1/10W,25ppm
31	1		3750-2	TM1	Red	BINDING POST, RED 60V/15A GOLD ROHS
32	1		REG1117-3.3	U2	SOT223-DCY	VOLT REG 3.3V 800mA SOT223-DCY ROHS
33	1		PCM2705DB	U1	SSOP28-DB	STEREO AUDIO DAC W/USB SE HEADPHONE/SPDIF OUT SSOP28-DB ROHS

NOTE: ASTERISK(*) NEXT TO PART MANUFACTURER'S NAME DENOTES POSSIBLE LONG LEAD TIME ITEM.

2.3 PCM270xEVM-U Printed-Circuit Board

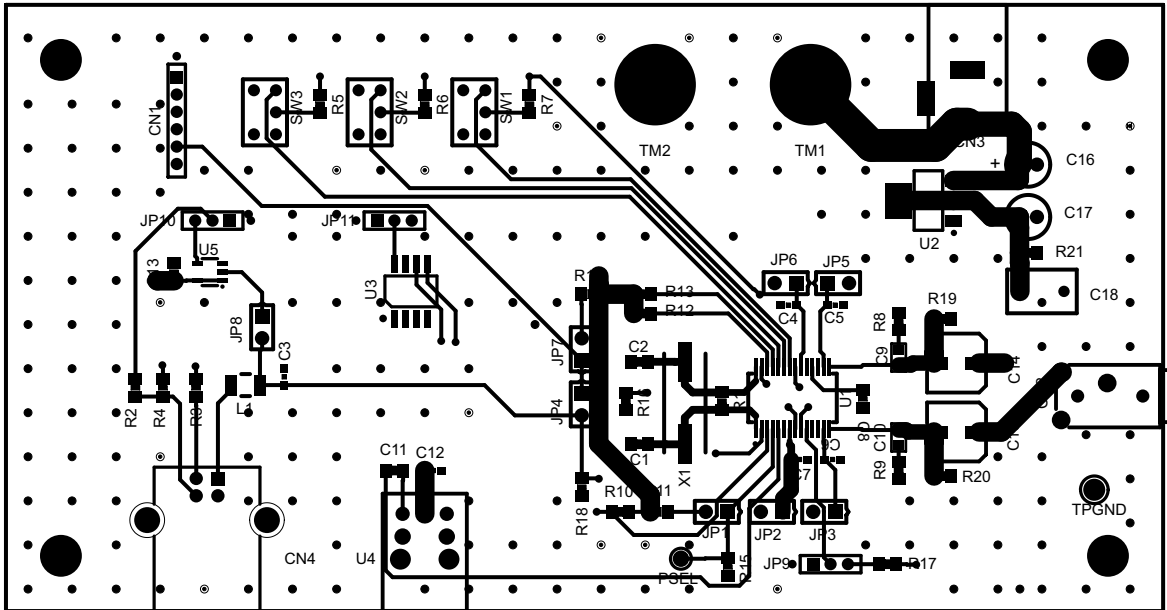

Figure 3. PCM270xEVM-U Silkscreen

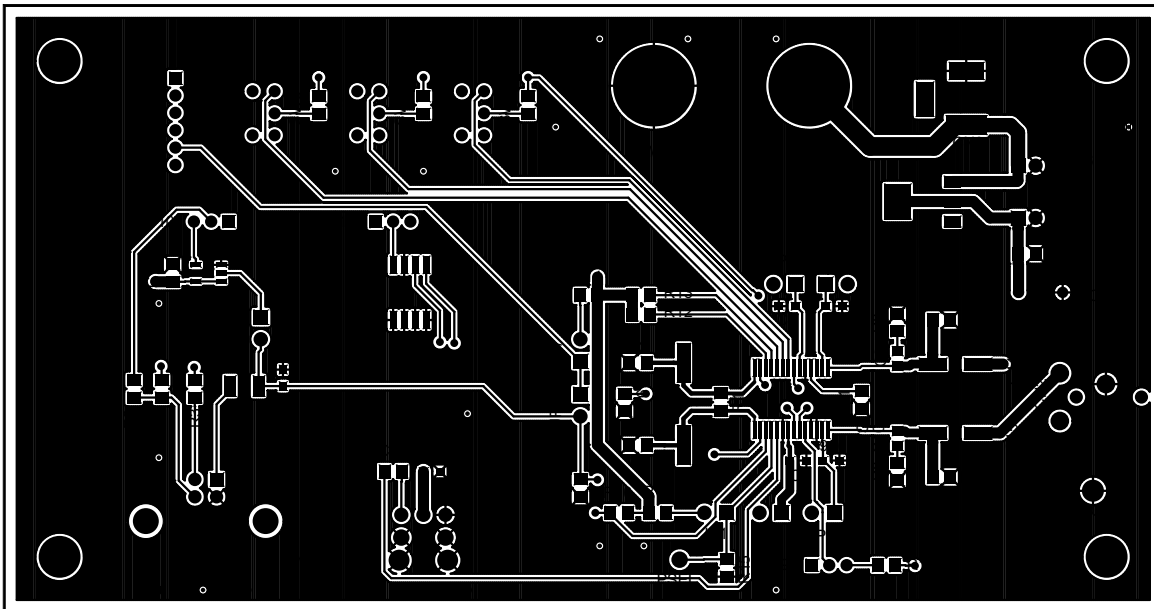

Figure 4. PCM270xEVM-U—Top View

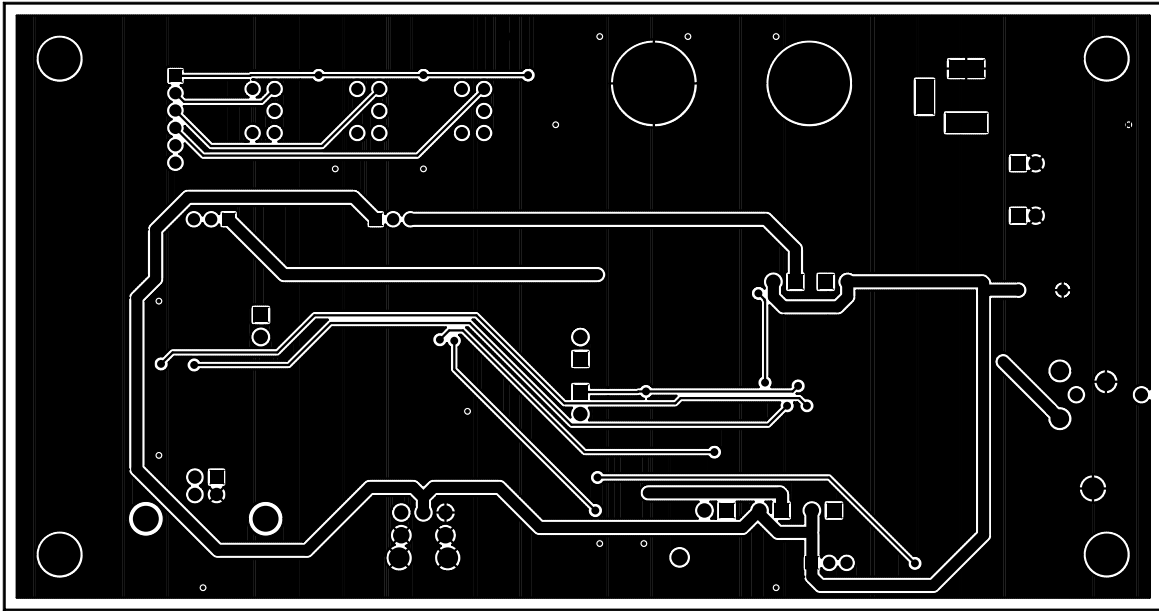

Figure 5. PCM270xEVM-U—Bottom View

Evaluation Board/Kit Important Notice

Texas Instruments (TI) provides the enclosed product(s) under the following conditions:

This evaluation board/kit is intended for use for **ENGINEERING DEVELOPMENT, DEMONSTRATION, OR EVALUATION PURPOSES ONLY** and is not considered by TI to be a finished end-product fit for general consumer use. Persons handling the product(s) must have electronics training and observe good engineering practice standards. As such, the goods being provided are not intended to be complete in terms of required design-, marketing-, and/or manufacturing-related protective considerations, including product safety and environmental measures typically found in end products that incorporate such semiconductor components or circuit boards. This evaluation board/kit does not fall within the scope of the European Union directives regarding electromagnetic compatibility, restricted substances (RoHS), recycling (WEEE), FCC, CE or UL, and therefore may not meet the technical requirements of these directives or other related directives.

Should this evaluation board/kit not meet the specifications indicated in the User's Guide, the board/kit may be returned within 30 days from the date of delivery for a full refund. **THE FOREGOING WARRANTY IS THE EXCLUSIVE WARRANTY MADE BY SELLER TO BUYER AND IS IN LIEU OF ALL OTHER WARRANTIES, EXPRESSED, IMPLIED, OR STATUTORY, INCLUDING ANY WARRANTY OF MERCHANTABILITY OR FITNESS FOR ANY PARTICULAR PURPOSE.**

The user assumes all responsibility and liability for proper and safe handling of the goods. Further, the user indemnifies TI from all claims arising from the handling or use of the goods. Due to the open construction of the product, it is the user's responsibility to take any and all appropriate precautions with regard to electrostatic discharge.

EXCEPT TO THE EXTENT OF THE INDEMNITY SET FORTH ABOVE, NEITHER PARTY SHALL BE LIABLE TO THE OTHER FOR ANY INDIRECT, SPECIAL, INCIDENTAL, OR CONSEQUENTIAL DAMAGES.

TI currently deals with a variety of customers for products, and therefore our arrangement with the user **is not exclusive.**

TI assumes **no liability for applications assistance, customer product design, software performance, or infringement of patents or services described herein.**

Please read the User's Guide and, specifically, the Warnings and Restrictions notice in the User's Guide prior to handling the product. This notice contains important safety information about temperatures and voltages. For additional information on TI's environmental and/or safety programs, please contact the TI application engineer or visit www.ti.com/esh.

No license is granted under any patent right or other intellectual property right of TI covering or relating to any machine, process, or combination in which such TI products or services might be or are used.

FCC Warning

This evaluation board/kit is intended for use for **ENGINEERING DEVELOPMENT, DEMONSTRATION, OR EVALUATION PURPOSES ONLY** and is not considered by TI to be a finished end-product fit for general consumer use. It generates, uses, and can radiate radio frequency energy and has not been tested for compliance with the limits of computing devices pursuant to part 15 of FCC rules, which are designed to provide reasonable protection against radio frequency interference. Operation of this equipment in other environments may cause interference with radio communications, in which case the user at his own expense will be required to take whatever measures may be required to correct this interference.

EVM Warnings and Restrictions

It is important to operate this EVM within the input voltage range of 5 V and the output voltage range of 5 V .

Exceeding the specified input range may cause unexpected operation and/or irreversible damage to the EVM. If there are questions concerning the input range, please contact a TI field representative prior to connecting the input power.

Applying loads outside of the specified output range may result in unintended operation and/or possible permanent damage to the EVM. Please consult the EVM User's Guide prior to connecting any load to the EVM output. If there is uncertainty as to the load specification, please contact a TI field representative.

During normal operation, some circuit components may have case temperatures greater than 55°C. The EVM is designed to operate properly with certain components above 55°C as long as the input and output ranges are maintained. These components include but are not limited to linear regulators, switching transistors, pass transistors, and current sense resistors. These types of devices can be identified using the EVM schematic located in the EVM User's Guide. When placing measurement probes near these devices during operation, please be aware that these devices may be very warm to the touch.

Mailing Address: Texas Instruments, Post Office Box 655303, Dallas, Texas 75265
Copyright © 2011, Texas Instruments Incorporated

IMPORTANT NOTICE

Texas Instruments Incorporated and its subsidiaries (TI) reserve the right to make corrections, modifications, enhancements, improvements, and other changes to its products and services at any time and to discontinue any product or service without notice. Customers should obtain the latest relevant information before placing orders and should verify that such information is current and complete. All products are sold subject to TI's terms and conditions of sale supplied at the time of order acknowledgment.

TI warrants performance of its hardware products to the specifications applicable at the time of sale in accordance with TI's standard warranty. Testing and other quality control techniques are used to the extent TI deems necessary to support this warranty. Except where mandated by government requirements, testing of all parameters of each product is not necessarily performed.

TI assumes no liability for applications assistance or customer product design. Customers are responsible for their products and applications using TI components. To minimize the risks associated with customer products and applications, customers should provide adequate design and operating safeguards.

TI does not warrant or represent that any license, either express or implied, is granted under any TI patent right, copyright, mask work right, or other TI intellectual property right relating to any combination, machine, or process in which TI products or services are used. Information published by TI regarding third-party products or services does not constitute a license from TI to use such products or services or a warranty or endorsement thereof. Use of such information may require a license from a third party under the patents or other intellectual property of the third party, or a license from TI under the patents or other intellectual property of TI.

Reproduction of TI information in TI data books or data sheets is permissible only if reproduction is without alteration and is accompanied by all associated warranties, conditions, limitations, and notices. Reproduction of this information with alteration is an unfair and deceptive business practice. TI is not responsible or liable for such altered documentation. Information of third parties may be subject to additional restrictions.

Resale of TI products or services with statements different from or beyond the parameters stated by TI for that product or service voids all express and any implied warranties for the associated TI product or service and is an unfair and deceptive business practice. TI is not responsible or liable for any such statements.

TI products are not authorized for use in safety-critical applications (such as life support) where a failure of the TI product would reasonably be expected to cause severe personal injury or death, unless officers of the parties have executed an agreement specifically governing such use. Buyers represent that they have all necessary expertise in the safety and regulatory ramifications of their applications, and acknowledge and agree that they are solely responsible for all legal, regulatory and safety-related requirements concerning their products and any use of TI products in such safety-critical applications, notwithstanding any applications-related information or support that may be provided by TI. Further, Buyers must fully indemnify TI and its representatives against any damages arising out of the use of TI products in such safety-critical applications.

TI products are neither designed nor intended for use in military/aerospace applications or environments unless the TI products are specifically designated by TI as military-grade or "enhanced plastic." Only products designated by TI as military-grade meet military specifications. Buyers acknowledge and agree that any such use of TI products which TI has not designated as military-grade is solely at the Buyer's risk, and that they are solely responsible for compliance with all legal and regulatory requirements in connection with such use.

TI products are neither designed nor intended for use in automotive applications or environments unless the specific TI products are designated by TI as compliant with ISO/TS 16949 requirements. Buyers acknowledge and agree that, if they use any non-designated products in automotive applications, TI will not be responsible for any failure to meet such requirements.

Following are URLs where you can obtain information on other Texas Instruments products and application solutions:

Products

Audio	www.ti.com/audio
Amplifiers	amplifier.ti.com
Data Converters	dataconverter.ti.com
DLP® Products	www.dlp.com
DSP	dsp.ti.com
Clocks and Timers	www.ti.com/clocks
Interface	interface.ti.com
Logic	logic.ti.com
Power Mgmt	power.ti.com
Microcontrollers	microcontroller.ti.com
RFID	www.ti-rfid.com
RF/IF and ZigBee® Solutions	www.ti.com/lprf

Applications

Communications and Telecom	www.ti.com/communications
Computers and Peripherals	www.ti.com/computers
Consumer Electronics	www.ti.com/consumer-apps
Energy and Lighting	www.ti.com/energy
Industrial	www.ti.com/industrial
Medical	www.ti.com/medical
Security	www.ti.com/security
Space, Avionics and Defense	www.ti.com/space-avionics-defense
Transportation and Automotive	www.ti.com/automotive
Video and Imaging	www.ti.com/video
Wireless	www.ti.com/wireless-apps

TI E2E Community Home Page

e2e.ti.com

Mailing Address: Texas Instruments, Post Office Box 655303, Dallas, Texas 75265
Copyright © 2011, Texas Instruments Incorporated