

LTC3851AEUD/
 LTC3851AEUD-1
 SYNCHRONOUS BUCK CONVERTER

DESCRIPTION

Demonstration circuit 1432A is a synchronous buck converter featuring the LTC3851AEUD/ LTC3851AEUD-1. The demo circuit is available in two versions. DC1432A-A is configured with LTC3851AEUD which provides ISET function, while the DC1432A-B is configured with LTC3851AEUD-1 which provides PGOOD function.

The main features of the board include an internal 5V linear regulator for bias and a Mode selector that allows the converter to run in Forced CCM Mode, Pulse Skip Mode or Burst Mode operation. Synchronization to an external clock is also possible on this board.

The demo circuit has an optional DCR sense circuit that allows using the inductor's DCR as the current sensing

element to save cost, footprint and improve full load efficiency about 2%.

The LTC3851AEUD/ LTC3851AEUD-1 datasheet gives a complete description of these parts, operation and application information and must be read in conjunction with this quick start guide for Demonstration circuit 1432A.

Design files for this circuit board are available. Call the LTC factory.

LT, LTC, LTM, LT, Burst Mode, OPTI-LOOP, Over-The-Top and PolyPhase are registered trademarks of Linear Technology Corporation. Adaptive Power, C-Load, DirectSense, Easy Drive, FilterCAD, Hot Swap, LinearView, µModule, Micropower SwitcherCAD, Multimode Dimming, No Latency ΔΣ, No Latency Delta-Sigma, No RSENSE, Operational Filter, PanelProtect, PowerPath, PowerSOT, SmartStart, SoftSpan, Stage Shedding, SwitcherCAD, ThinSOT, UltraFast and VLDO are trademarks of Linear Technology Corporation. Other product names may be trademarks of the companies that manufacture the products.

Table 1. Performance Summary (T_A=25°C)

PARAMETER	CONDITIONS	MIN	TYP	MAX	UNITS
Input Supply Range		4.5		14	V
Output Voltage Range	V _{IN} = 12V, I _{LOAD} = 15A	1.47	1.5	1.53	V
Nominal Switching Frequency			350		kHz
Full Load Efficiency (See Figure 3 for efficiency curves)	V _{IN} = 12V, V _{OUT} = 1.5V, I _{LOAD} = 15A		88.9		%

QUICK START PROCEDURE

Demonstration circuit 1432A is easy to set up to evaluate the performance of the LTC3851AEUD/ LTC3851AEUD-1. Refer to Figure 1 for proper measurement equipment setup and follow the procedure below:

NOTE. When measuring the input or output voltage ripple, care must be taken to avoid a long ground lead on the oscilloscope probe. Measure the input or output voltage ripple by touching the probe tip directly across the Vin or Vout and GND terminals. See Figure 2 for proper scope probe technique.

- Place jumpers in the following positions:
FREQ/PLLFLTR 350kHz
RUN On
MODE/PLLIN CCM
- With power off, connect the input power supply to Vin and GND.
- Turn on the power at the input.

NOTE. Make sure that the input voltage does not exceed 14V.

LTC3851AEUD/ LTC3851AEUD-1

4. Check for the proper output voltage. $V_{out} = 1.470V$ to $1.530V$

NOTE. If there is no output, temporarily disconnect the load to make sure that the load is not set too high.

5. Once the proper output voltages are established, adjust the loads within the operating range and observe

the output voltage regulation, ripple voltage, efficiency and other parameters.

6. Different operating modes can be evaluated by changing the position of **MODE/PLLIN** jumper and are discussed in the next section.

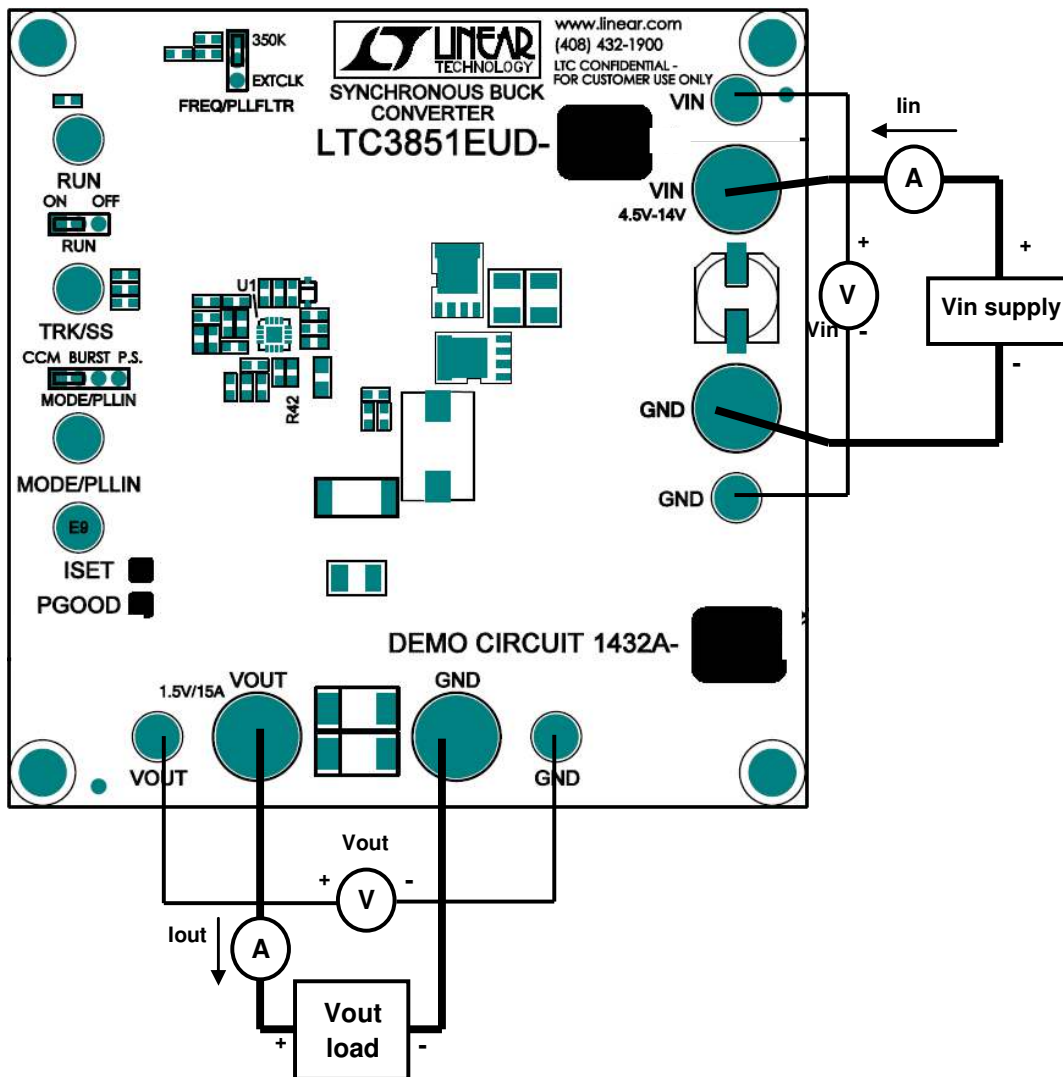

Figure 1. Proper Measurement Equipment Setup

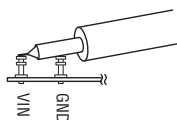

Figure 2. Measuring Input or Output Ripple

FREQUENCY SYNCHRONIZATION AND MODE SELECTION

Demonstration circuit 1432A's Mode selector allows the converter to run in Forced CCM Mode, Pulse Skip Mode or Burst Mode operation by changing position of **MODE/PLLIN** jumper. For synchronizing to an external clock source, **FREQ/PLLFLTR** jumper needs to be

placed at "EXTCLK" position and **MODE/PLLIN** jumper needs to be removed. Apply the external clock from the **MODE/PLLIN** turret to **GND**. Refer to Table 2 and to the data sheet for more details.

Table 2. Mode Selection and Synchronizing Operation Options

CONFIGURATION	MODE/PLLIN JUMPER	FREQ/PLLFLTR JUMPER
Forced CCM Mode Operation	"CCM"	"350K"
Pulse Skip Mode Operation	"P.S."	"350K"
Burst Mode Operation	"BURST"	"350K"
Synchronize to Ext. clock (Ext. clock apply to MODE/PLLIN turret)	Remove Jumper	"EXTCLK"

RAIL TRACKING

Demonstration circuit 1432A is configured for an on board soft start circuit. The soft start ramp rate can be adjusted by changing the value of C24. Demonstration

circuit 1432A can also be modified to track an external reference. Refer to Table 3 for tracking options and to the data sheet for more details.

Table 3. Output Tracking Options

CONFIGURATION	R32	R35	C24	TRK/SS PIN
Soft Start Without Tracking (Default)	0Ω	OPEN	0.1μF	OPEN
Vout Equals External Ramp	0Ω	OPEN	OPEN	External Ramp
Vout Tracking Scaled External Ramp	Resistor Divider		OPEN	External Ramp

OPTIONAL INDUCTOR DCR CURRENT SENSING

Demonstration circuit 1432A provides an optional circuit for Inductor DCR Current Sensing. Inductor DCR Current Sensing uses the DCR of the inductor to sense the inductor current instead of discrete sense resistors. The advantages of DCR sensing are lower cost, reduced board space and higher efficiency, but the dis-

advantage is a less accurate current limit. If DCR sensing is used, be sure to select an inductor current with a sufficiently high saturation current or use an iron powder type. Refer to Table 4 for Optional Inductor DCR Current Sensing setup and to the datasheet for more details.

Table 4. Optional Inductor DCR Current Sensing

CONFIGURATION	RSNSE	R10	R9	R1	C30	R27
Current Sense Resistor (Default)	2mΩ, 1W	100 Ω	100 Ω	OPEN	1nF	OPEN
Inductor DCR Current Sensing	0Ω Copper	OPEN	OPEN	0 Ω	100nF	2k Ω

LTC3851AEUD/ LTC3851AEUD-1

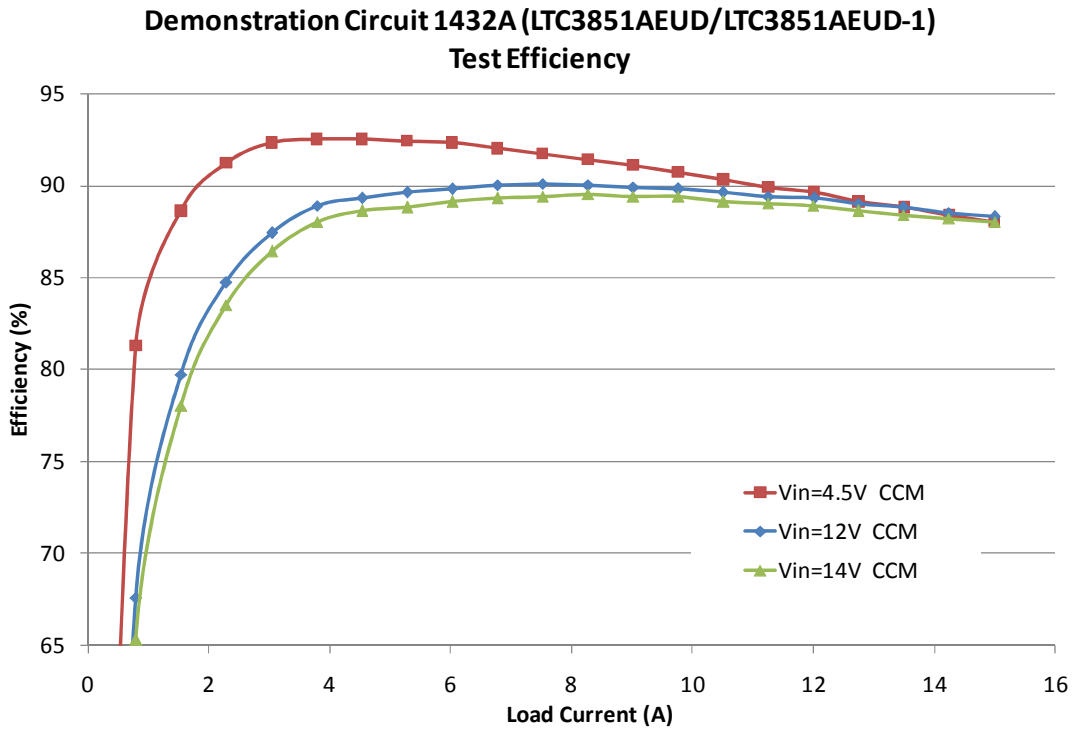

Figure 3. Efficiency Curve for Demonstration Circuit 1432A

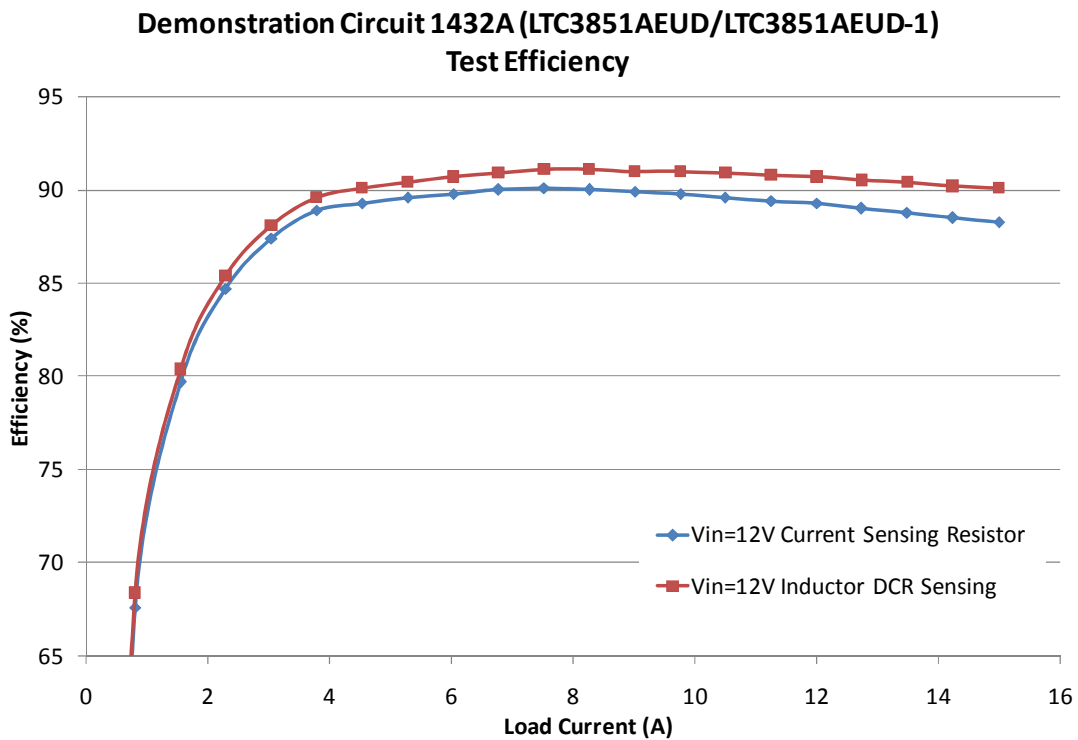
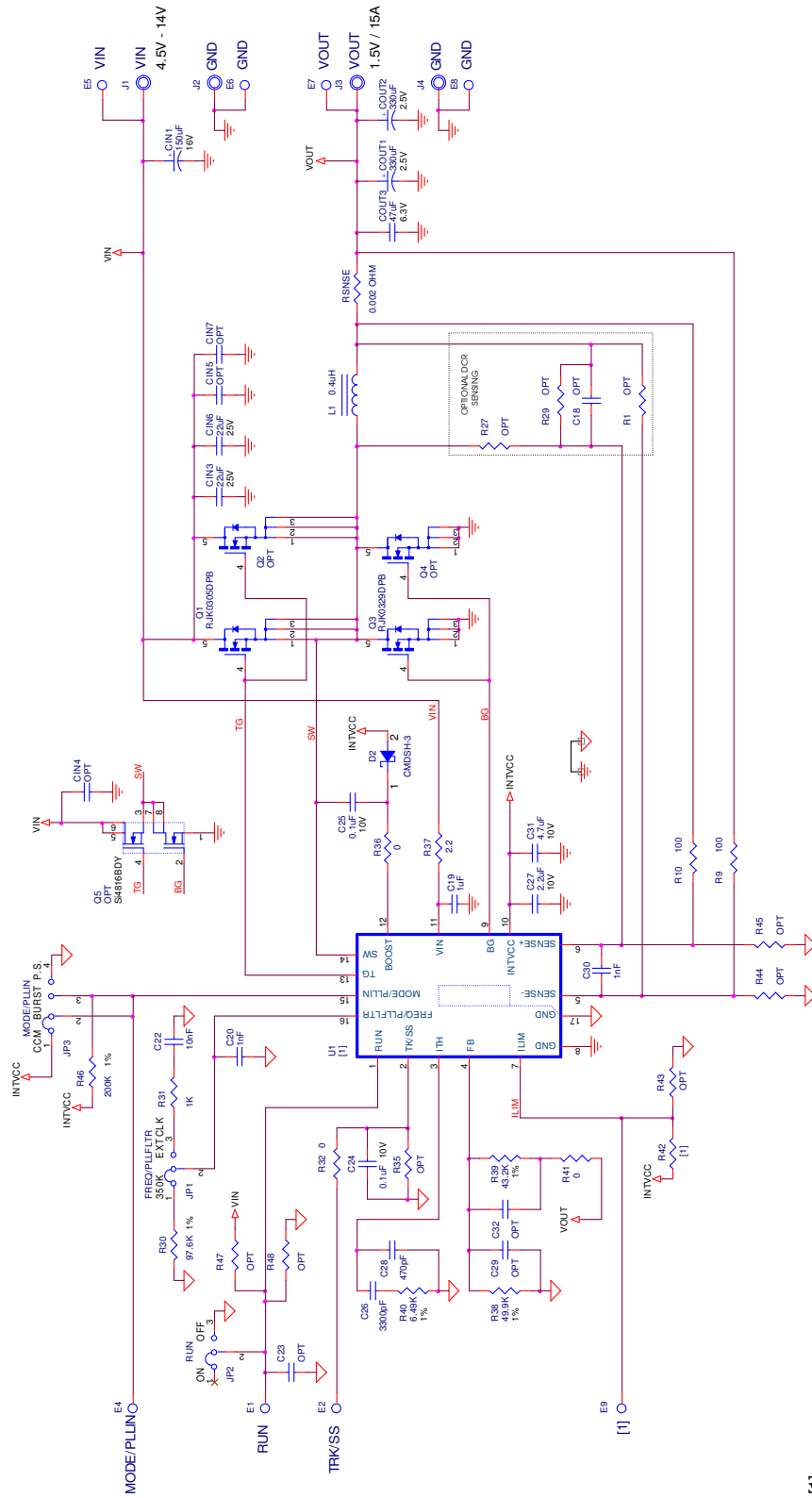

Figure 4. Efficiency Curve for Demonstration Circuit 1432A with Optional Inductor DCR Current Sensing

LTC3851AEUD/ LTC3851AEUD-1



[1]

Figure 5. Demonstration Circuit 1432A Schematic