

CLP Series -G (RoHS Device)

Schematics:

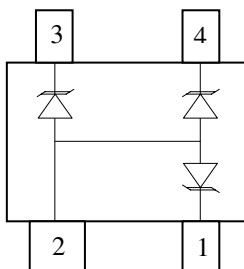

Package:

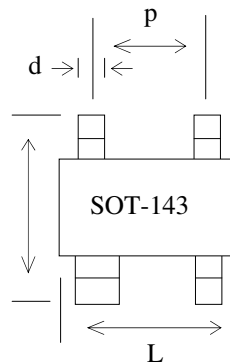

Dimensions in (mm):

Package Code	Total Power	Number of Pins	L ± 0.2	W ± 0.2	p ± 0.1	e ± 0.1	Pkg. Height ± 0.2	d ± 0.1	c (ref.)
S14	225 mw	4	2.92	2.30	1.91	--	0.95	0.43	.038

Application:

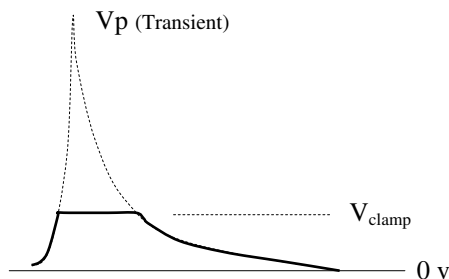
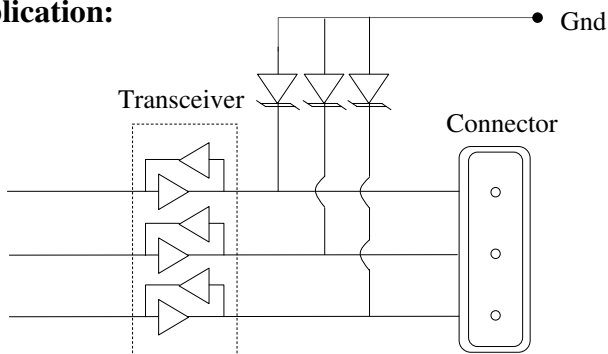

Specifications:(Ta = 25°C)

5V0 Characteristic

Symbol	Characteristic	Min	Typ	Max	Units	Test Condition
V _{BD}	Diode breakdown voltage	5.1	7.0		V	I _F = 1 ma
I _L	Leakage current		+0.1	+ 2.0	uA	5v
C _T	Capacitance		15	20	pF	@ 1Mhz
V _{ESD}	Channel clamp voltage			± 7.0	V	8kV event
V _{PV}	Peak ESD voltage capability			16	kV	IEC 61000-4-2
I _{pp} *	Peak Pulse Current			5.1	A	8 / 20 us
To	Operating Temp. Range	-55		+155	°C	

* one diode conducting

Ordering Information:

CLP	S14	5V0	-G
Type	Package Code	Voltage	RoHS Compliance
CLP	S14 – SOT143	5V0	-G

* 3,000 units per reel