

THIS DRAWING IS UNPUBLISHED.  
 DIFFUSION RESTREINTE AMP  
 © COPYRIGHT 20 BY TYCO ELECTRONICS CORPORATION. ALL RIGHTS RESERVED.  
 TOUS DROITS RESERVES

RELEASED FOR PUBLICATION  
 LIBRE A LA DIFFUSION  
 20

LOC	DIST	REVISIONS				
P	LTR REV	DESCRIPTION MODIFICATIONS	DATE	DWN DESS.	APVD APP.	
F	7	G	140617/140722-1/-2 REACTIVE	OCT1992	JJD -	
		H	REDESSINE EN CAO	13OCT2000	JJD -	
		HI	REVISED PER ECR-17-009309	06JUL2017	BH RP	

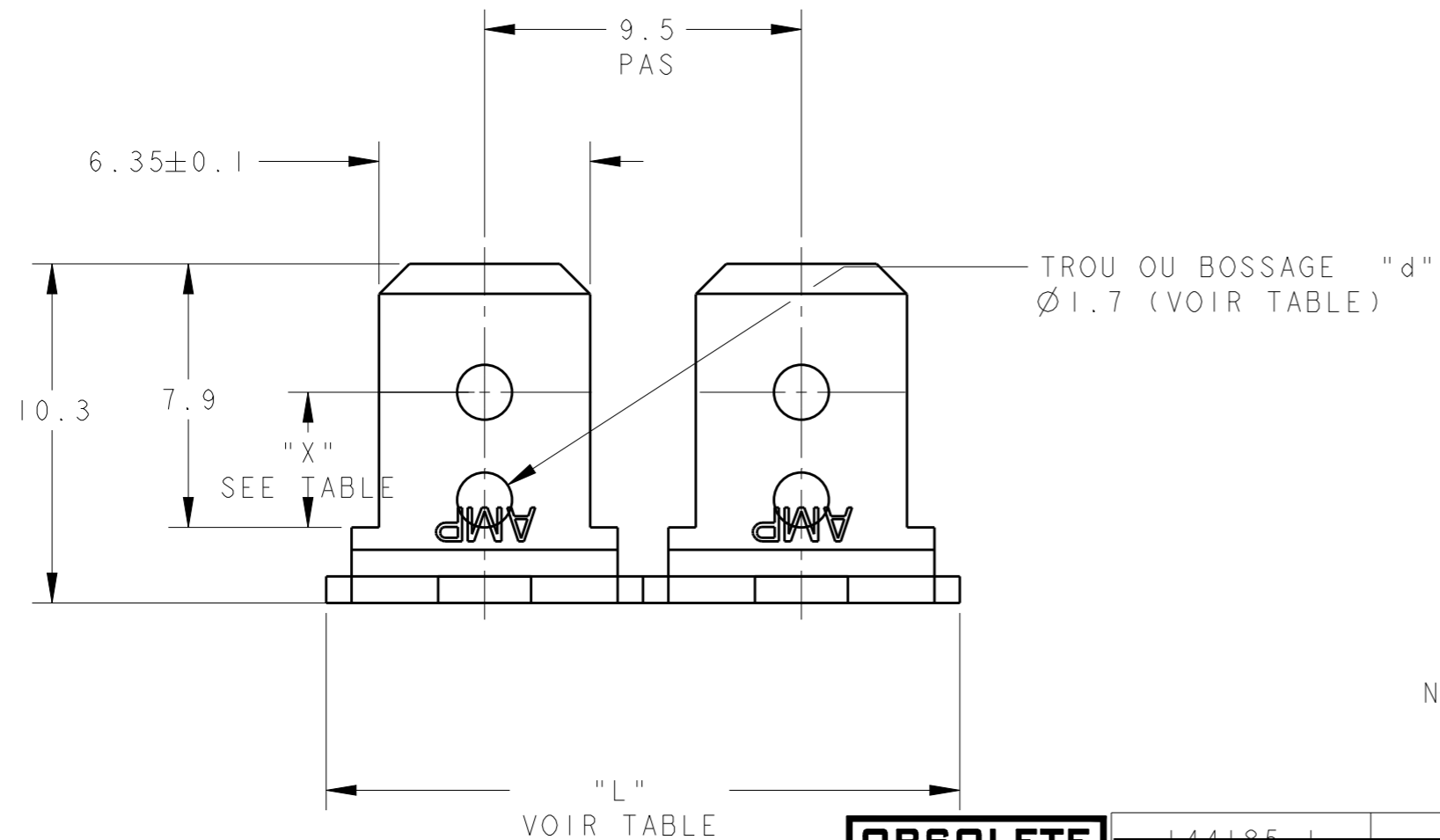

NOTE : la position du trou (cote 4.1) est hors standard pour les ref. 141705-1/-2

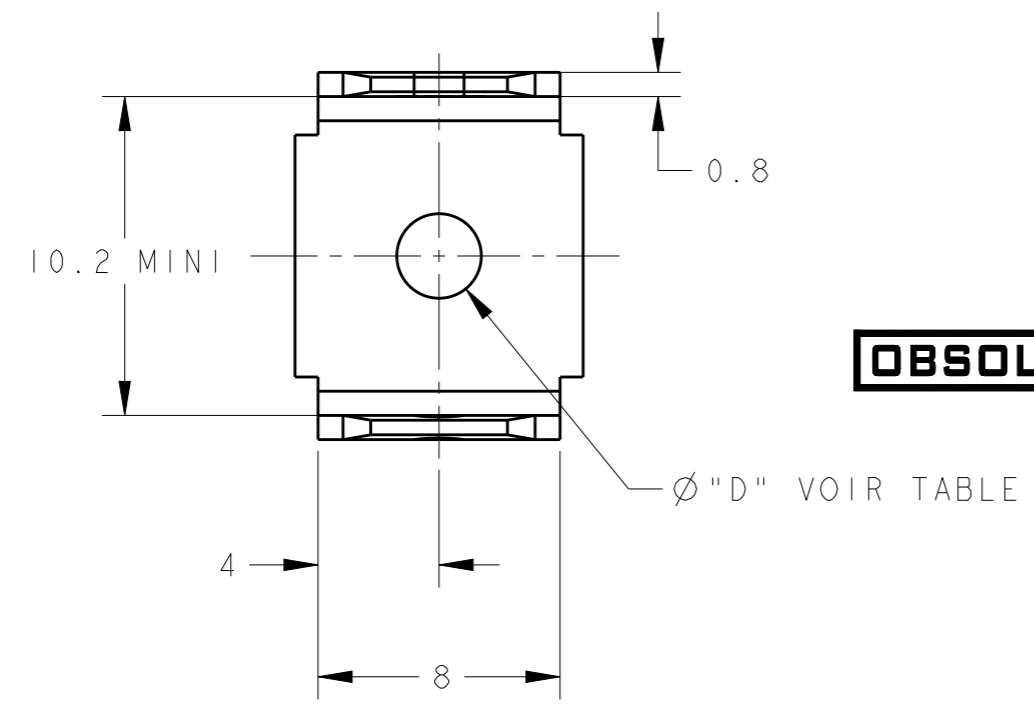

**OBSOLETE**

**OBSOLETE**

Reference	Finition	"L"	"D" <sup>+0.12</sup> <sub>-0</sub>	"X"±0.1	"d"	Nombre de paires
144185-1	brut	17.6	4.1	3.4	trou	2
141878-3	brut	en bande	4.1	3.4	trou	en bande
141878-2	etame	8	4.1	3.4	trou	1
141878-1	brut	8	4.1	3.4	trou	1
141705-2	etame	27.3	4.1	4.05	trou	3
141705-1	brut	27.3	4.1	4.05	trou	3
140722-2	etame	en bande	4.1	4.05	bossage	en bande
140722-1	brut	en bande	4.1	4.05	bossage	en bande
140617-0	brut	27.3	4.1	4.05	bossage	3
140613-0	brut	8	4.1	4.05	bossage	1

THIS DRAWING IS A CONTROLLED DOCUMENT FOR TYCO ELECTRONICS CORPORATION IT IS SUBJECT TO CHANGE AND THE CONTROLLING ENGINEERING ORGANIZATION SHOULD BE CONTACTED FOR THE LATEST REVISION.  
 CE PLAN EST UN DOCUMENT CONTROLE PAR AMP INCORPORATED. IL EST SUSCEPTIBLE D'ETRE REVISE. CONTACTER LE SERVICE TECHNIQUE D'AMP DE FRANCE POUR OBTENIR LA DERNIERE REVISION.

DWN/DESSINE JJ. DESPRETZ 13OCT2000  
 CHK/VERIFIE -  
 APVD/APPROUVE -  
 PRODUCT SPEC SPEC. PRODUIT -  
 APPLICATION SPEC SPEC. APPLICATION -  
 WEIGHT MASSE APPROX. -

**AMP** AMP DE FRANCE  
 95301 PONTOISE

NAME TITRE  
 LANGUETTE DOUBLE  
 PLIEE A 90 DEG.  
 FASTON TABS .250 SERIES BENT

SIZE FORMAT A3  
 CAGE CODE 00779  
 DRAWING NO No PLAN C-140613  
 RESTRICTED TO RESERVE A -

MATERIAL /MATIERE LAITON  
 FINISH /FINITION VOIR TABLE

CUSTOMER DRAWING /PLAN CLIENT UNIQUEMENT POUR REFERENCE  
 SCALE ECHELLE 5:1  
 SHEET FEUILLE 1 OF DE 1  
 REV HI