

# SPECIFICATIONS

PARAMETERS	VALUES	UNITS
RATED VOLTAGE	12	Vdc
OPERATING VOLTAGE RANGE	1.5 ~ 20	Vdc
RATED CURRENT (MAX)	10	mA
MINIMUM SPL @ 10 CM	106	dBA
RESONANT FREQUENCY	2,800 ± 500	Hz
TONE OR PULSE RATE	CONTINUOUS	0 pulse/sec
OPERATING TEMPERATURE	-20 ~ +60	°C
STORAGE TEMPERATURE	-30 ~ +70	°C
HOUSING MATERIAL	ABS	-
TERMINAL MATERIAL	LEAD WIRE	-
WEIGHT	15	grams

THIS DOCUMENT CONTAINS DATA PROPRIETARY TO PROJECTS UNLIMITED, INC. ANY USE OR REPRODUCTION, IN ANY FORM, WITHOUT PRIOR WRITTEN PERMISSION OF PROJECTS UNLIMITED, INC. IS PROHIBITED.  
©2003, Projects Unlimited Inc.

# REVISION HISTORY

LTR	DESCRIPTION	DATE	APPROVED
-	RELEASED FROM ENGINEERING	5/24/2006	
A	REVISED TEMPERATURE SPECIFICATIONS	8/24/2007	R.W.
B	REVISED TO INVENTOR 3-D DRAWING TEMPLATE	3/4/2008	B.R.
C	REVISED TEMP RANGES, ADD NOTE FOR BLACK GLUE	8/26/2015	M.L.

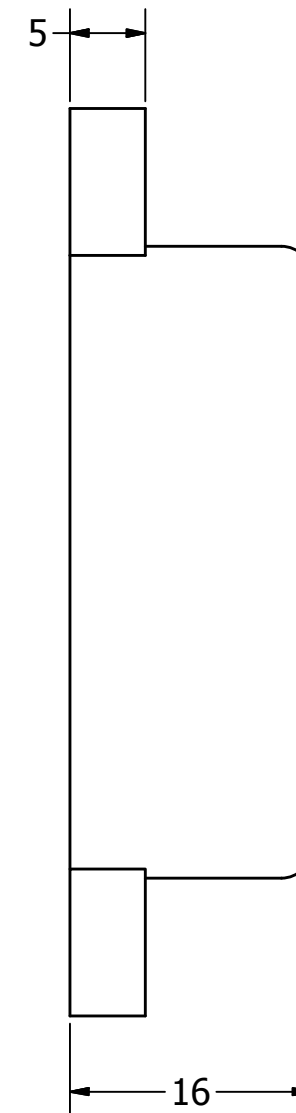
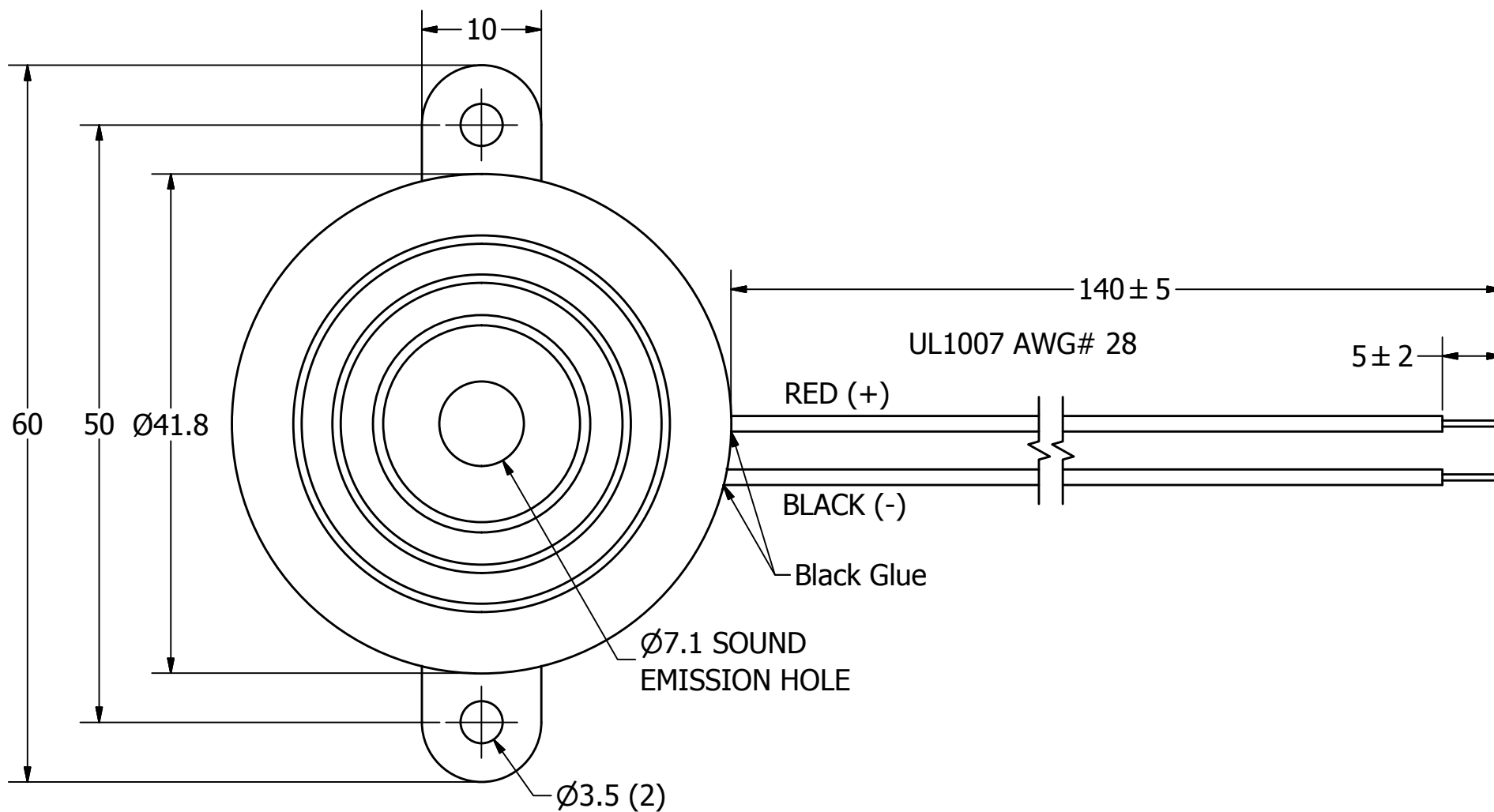

## NOTES:

1. ALL DIMENSIONS ARE IN MILLIMETERS.
2. SPECIFICATIONS SUBJECT TO CHANGE OR WITHDRAWL WITHOUT NOTICE.
3. THIS PART IS RoHS 2011/65/EU COMPLIANT.

UNLESS OTHERWISE SPECIFIED: DIMENSIONS ARE IN MILLIMETERS, TOLERANCES ARE ±0.5 AND ANGLES ARE ±3°.	SIZE <b>A3</b>	Designed by	Date	Checked by	Date	Approved by	Date	Drawn Date
		J.D.	5/24/2006	B.R.	5/24/2006	E.P.	5/24/2006	3/4/2008
AI-4228-TF-LW140-C-R.idw				<b>AI-4228-TF-LW140-C-R</b>			Indicator	
							Edition	Sheet
							-	1 / 1