

4

3

2

1

THIS DRAWING IS UNPUBLISHED. RELEASED FOR PUBLICATION ,19 .  
 © COPYRIGHT 19 BY AMP INCORPORATED. ALL RIGHTS RESERVED.

LOC	DIST	REVISIONS			
P	LTR	DESCRIPTION	DATE	DWN	APVD
G	14	E	REL -1 PER PR 96-3010-001	20AUG96	ME SB

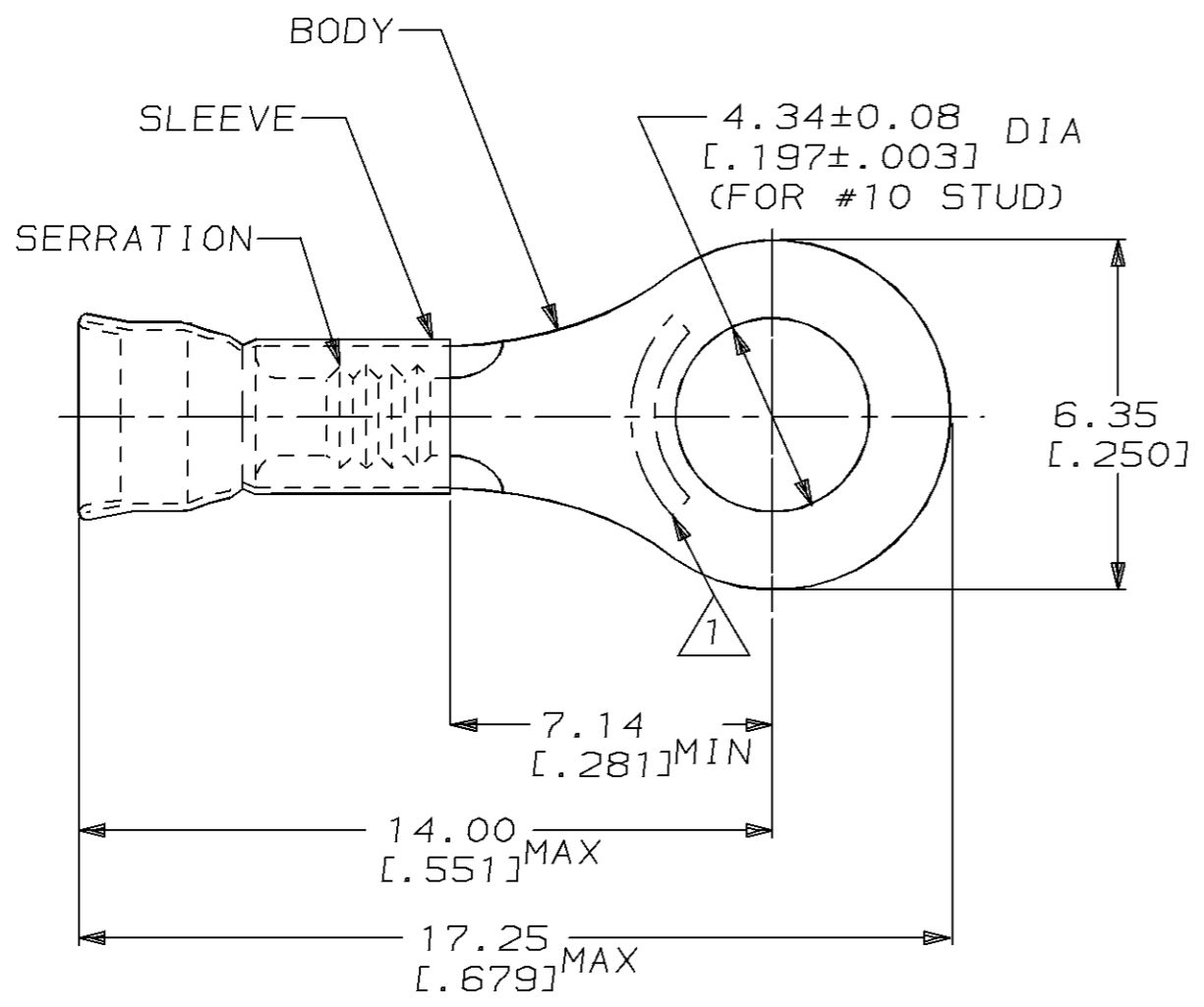

△ STAMP AMP LOCATE APPROX AS SHOWN

- WIRE INSUL DIA,  $1.27-2.08$  [ $.050-.082$ ]
- TONGUE MATL THK,  $0.46 \pm 0.05$  [ $.018 \pm .002$ ]

-	-	-
1000	LOOSE PIECE	32863-1
QTY	PACKAGE TYPE	PART NO

AMP INCORPORATED  
 CUSTOMER SERVICE SYSTEM

FOR ADDITIONAL PRODUCT INFORMATION OR COPIES OF DRAWINGS AND TECHNICAL DOCUMENTS: PRODUCT INFORMATION CENTER 1-800-522-6752

FOR APPLICATION TOOLING INFORMATION: TOOLING ASSISTANCE CENTER 1-800-722-1111

FOR ORDER ENTRY: 1-800-526-5142

MAX RECOMMENDED OPERATING TEMPERATURE: -

VOLTAGE RATING: -

CIRCULAR MIL AREA:  $0.10\text{mm}^2-0.41\text{mm}^2$  [202-#10]

STRANDED WIRE

THIS DRAWING IS A CONTROLLED DOCUMENT FOR AMP INCORPORATED. IT IS SUBJECT TO CHANGE AND THE CONTROLLING ENGINEERING ORGANIZATION SHOULD BE CONTACTED FOR THE LATEST REVISION.

DIMENSIONS: mm [in]

TOLERANCES UNLESS OTHERWISE SPECIFIED:

0 PLC	±-
1 PLC	±-
2 PLC	±0.20 [0.008]
3 PLC	±-
4 PLC	±-
ANGLES	±-

MATERIAL: BODY, CU, SLV, CU PER ASTM B152

FINISH: GOLD PLT PER MIL-6-45204 OVER NICKEL PLT. PER QQ-N-290

DWN L OLMEDA 23JAN95

CHK M ELLIS 23JAN95

APVD S BORTNER 23JAN95

PRODUCT SPEC

APPLICATION SPEC

WEIGHT -

CUSTOMER DRAWING

AMP Incorporated  
 Harrisburg, PA 17105-3608

NAME: TERMINAL, RING, DIAMOND GRIP™, WIRE SIZE, 26-22 AWG

SIZE: A3 CAGE CODE: 00779 DRAWING NO: C-32863

SCALE: 6:1 SHEET: 1 OF 1 REV: E