

**Microblower MZB1001T02**

**1. Feature**

- High speed & high pressure air blowing
- Less pulsation air flow
- Quick response
- Small size : 20 x 20 mm, t=1.85mm(nozzle height :1.6mm)
- Light weight

**2. Appearance**

Outside dimension/tolerance	20.0±0.15mm	
Thickness tolerance	1.85±0.2mm	except the nozzle
Nozzle height/tolerance	1.6±0.15mm	from top of the nozzle to top plate ※
Weight	1.4±0.2 g	

※ Dimension is calculated from the overall height and the thickness.

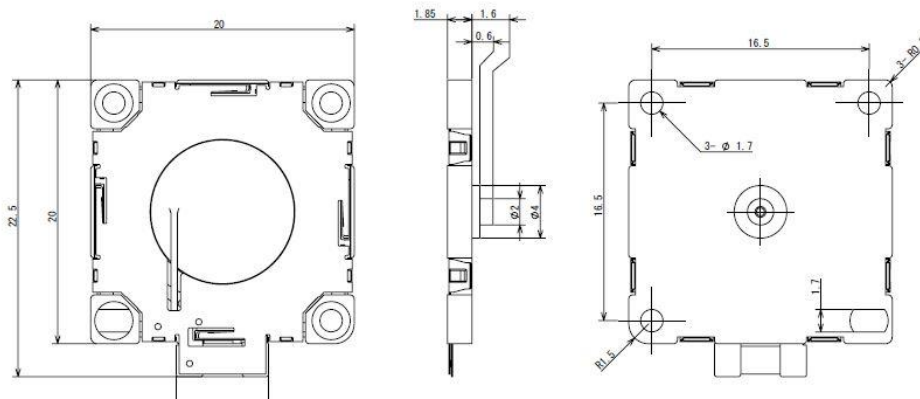

The dimensions shown in the above figure are reference values.  
The dimensions not described in the table are outside the scope of warranty.

**3. Marking**

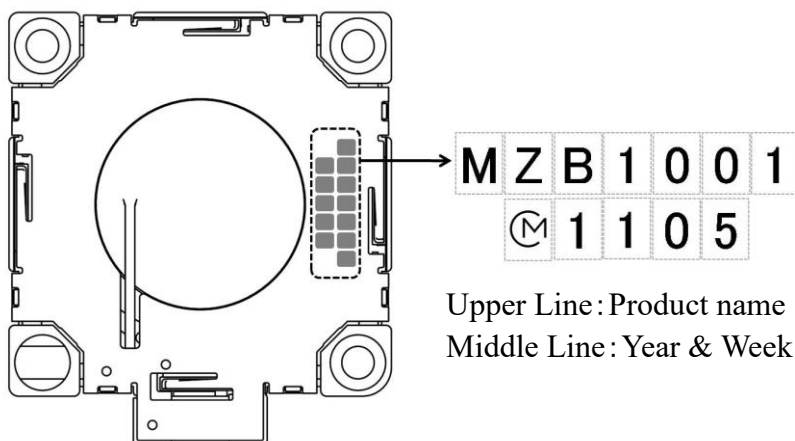

**4. Ratings**

Rating	Range	Unit
Operating Voltage Range	10 to 20	Vp-p
Absolute maximum rating voltage	30	Vp-p
Environmental Operating Temperature Range	0 to +70	°C

**5. Electrical Characteristics**

Parameter	Specification	Unit	Conditions
Resonant Frequency	24.0 to 27.0	kHz	Section 6
Flow Rate	$\geq 0.70$	L/min.	Section 6 Back Pressure:0.05kPa
Static Pressure	$\geq 1.42$	kPa	Section 6

**6. Measuring Method**

(Measuring Condition)

Driving voltage: 15Vp-p

Unless otherwise specified, the standard range of atmospheric conditions for making measurements and tests is as follows:

- Ambient temperature : 15°C to 35°C
- Relative humidity : 25% to 85%

If there is any doubt about the results, measurement shall be made within the following limits:

- Ambient temperature : 25 ± 2°C
- Relative humidity : 60% to 70%
- Air pressure : 960 hPa to 1060 hPa

(Measuring connection diagram)

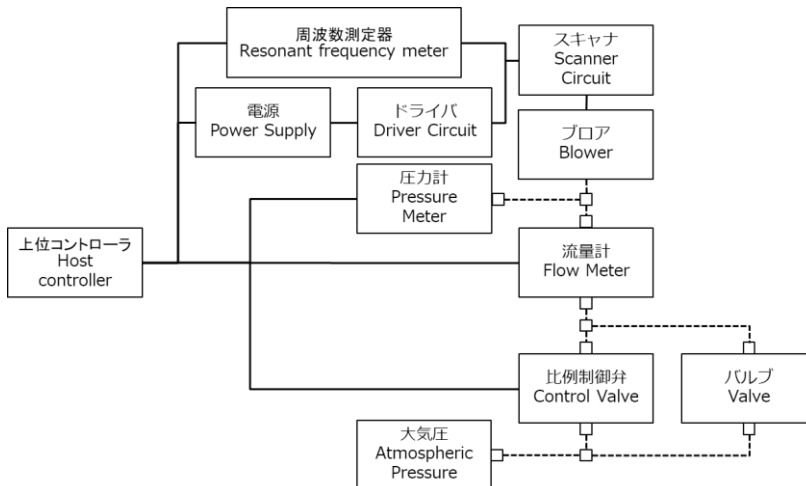

7. Typical Characteristic

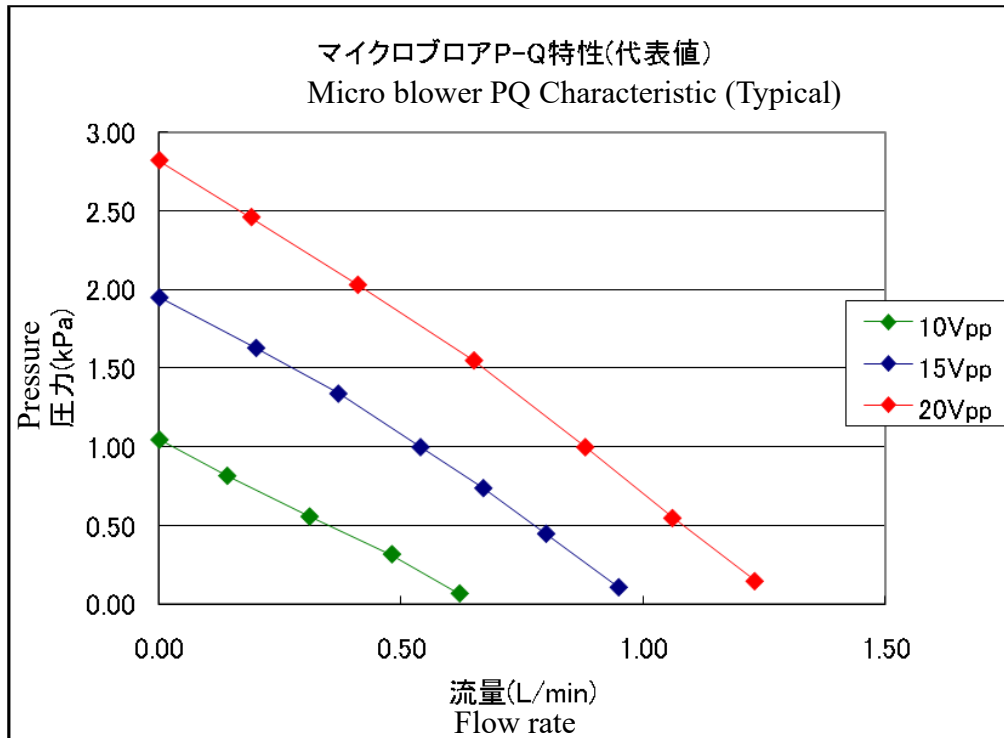

8. Reliability

Physical Characteristics

Item	Test Condition	Number	Result
1	Vibration Applying the vibration of maximum amplitude 1.5mm and vibration frequency 10 to 500Hz/10G in each of 3 perpendicular directions for 2 hours.	10	G
2	Shock Applying the shock of 30G once for six aspects.	10	G
3	Solder-ability After being kept in pressure cooker at +105°C and 100%R.H. for 4 hours, electrodes terminal shall be placed in a solution of rosin 25wt% and IPA75wt% for 5 seconds, and then immersed in a solder bath of +245±5°C for 3±0.5 seconds. Only terminal board shall be tested.	5	G

Note) These are the results in our company test condition

Environmental Characteristics

	Item	Test Condition	Number	Result
1	Dry Heat (Storage)	Blower shall be left in a chamber (Temperature: +85±2°C) for 500 hours, then measured after leaving in natural condition for 1 hour.	20	G
2	Dry Heat, Power Supplied Test	20V is applied to blower and blower shall be left in a chamber (Temperature: +85±2°C) for 500 hours, then measured after leaving in natural condition for 1 hour.	20	G
3	Cold (Storage)	Blower shall be left in a chamber (Temperature: -40±2°C) for 500 hours, then measured after leaving in natural condition for 1 hour.	20	G
4	Humidity	Blower shall be left in a chamber (85% R.H. at +85±2°C) for 500 hours, then measured after leaving in natural condition for 1 hour.	20	G
5	Humidity, Power Supplied Test	20V is applied to blower and blower shall be left in a chamber (93% R.H. at +60±2°C) for 500 hours, then measured after leaving in natural condition for 1 hour.	20	G
6	Thermal Shock	After being kept at room temperature, blower shall be placed at temperature of -40°C. After 30 minutes at this temperature, blower shall be within a few minutes placed at temperature of +85°C. After 30 minutes at this temperature, and blower shall be returned to -40°C again. After 500 above cycles, blower shall be returned to room temperature. And blower shall be measured after being placed in natural condition for 1 hour.	20	G

Note) These are the results in our company test condition (clean condition).

9. Tray Packing

Dimensions of Tray

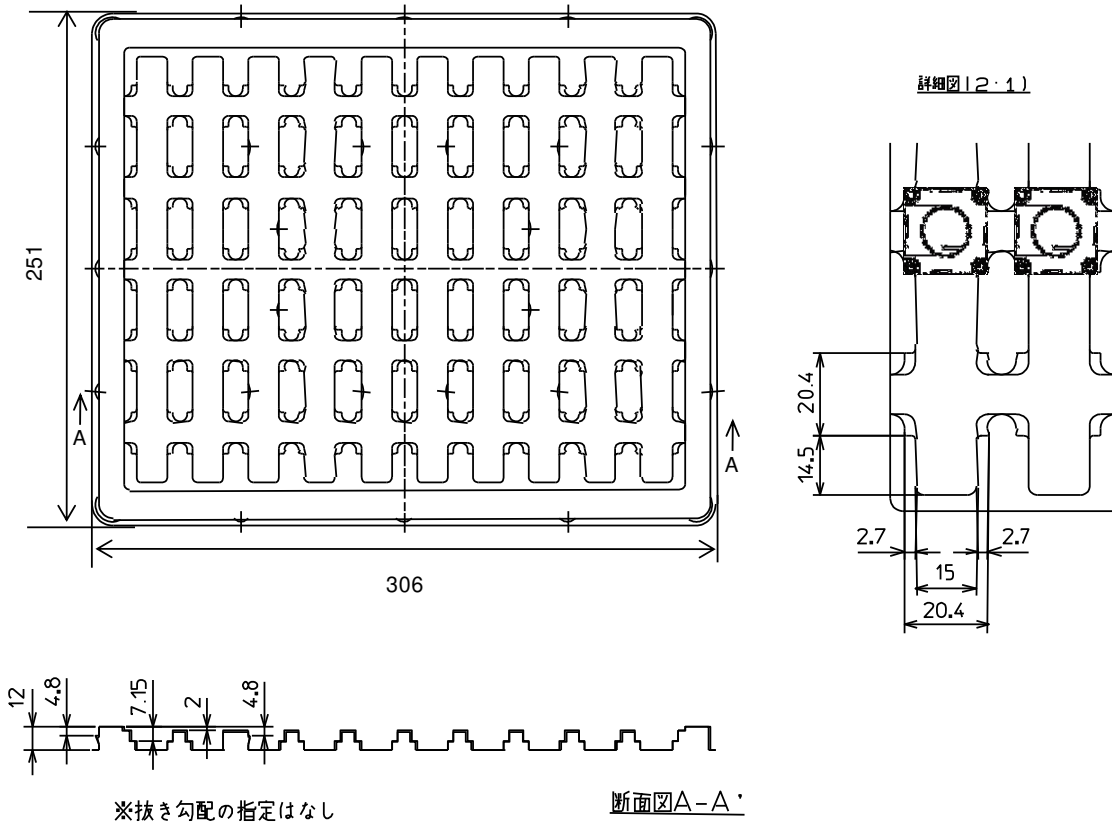

Packaging Form

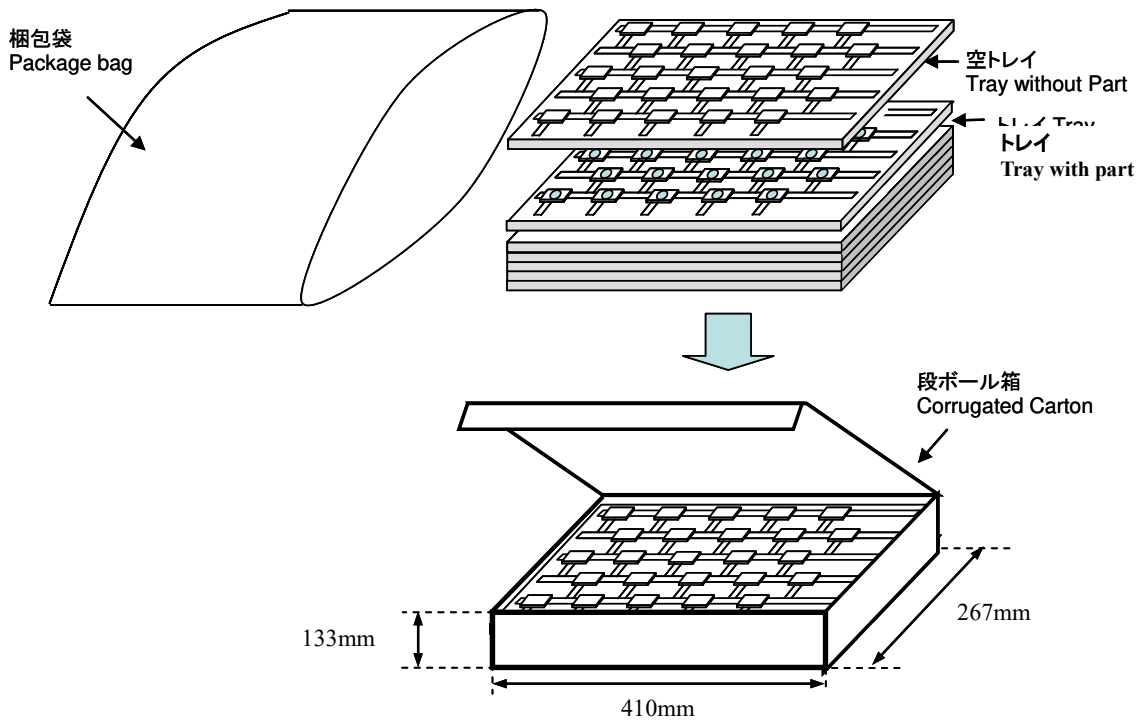

The Quantity per a box

Maximum Packaging Quantity: 700 pieces max. (= 50 pieces /tray x 14 trays)  
 However, total number of tray is 15 pieces because empty tray is set on top of other tray.

Content of Outer Label

The minimum packaging unit shall be a box. Each minimum package unit of blowers shall be in a carton box and it shall be clearly marked with your company name, customer's and Murata's part numbers, quantity and soon.

**10. Condition for soldering**

Please use the soldering iron.

Soldering iron conditions

Temperature of iron	Max350°C
Contact time	Within 3 second

Please do not touch the component with the soldering iron directly.  
 The component may be damaged if the component is used except the above conditions.  
 Please contact us if you use except the above conditions.

**(Reference material)**

The condition for measuring is following.

Item	Condition
Iron head temperature	345±5°C
Contact time	Within 3 second
Iron head shape	2C
Solder	Lead-free solder (Sn: 96.5%, Ag: 3%, Cu: 0.5%)

**Notices**

## 1. Cautions for Use

- 3-1 Our company doesn't bear any responsibility with respect to problems connecting the product with your equipment.
- 3-2 Since the product sucks and discharges air, contaminants and dust in the air tend to accumulate inside the pump, and the contaminants and dust will influence the operation time. Please use the product in a clean environment, or use a filter to remove at least submicron level of contaminants to prevent particles and dust from entering.  
(※The use of filter does not guarantee suppression of the characteristics deterioration of the product.) Our company doesn't bear any responsibility with respect to the problems.
- 3-3 The smoke of tobacco, mosquito-repellant incense etc. may influence a product life
- 3-4 Please do not touch the component (included nozzle, wiring etc.) with bare hands.
- 3-5 Please do not touch a wiring and the piezoelectric ceramic of the component inside
- 3-6 Applying load or stress on the product may cause crack in the ceramic element and damage to product. Please handle with care
- 3-7 Please pay attention to protect operating circuit from surge voltage provided by something of force such as falling, shock and temperature changing.
- 3-8 Please don't use dropped product because it has concern of the influence on characteristics.
- 3-9 Please pay attention never to apply DC voltage to the product.
- 3-10 Please take electrostatic countermeasure with wrist band etc.
- 3-11 This product is not sealing up structure and non- waterproof, and no use for liquid and no washing. Please avoid using in the condensation environment.
- 3-12 Recommend fixing with double coated adhesive tape.
- 3-13 The oxidation or the corrosion of the terminal electrode by the long keeping in the corrosive gas (hydrogen sulfide, sulfur dioxide, chlorine, ammonia etc.) and water with dissolved salt, may lead to characteristic deterioration, trouble and destruction.
- 3-14 There are cases that the color of the piezoelectric change by long-term safekeeping and operation environment, but no influence on the characteristic.
- 3-15 Adhesive on a piezoelectric or a metal plate have no influence on the characteristic.
- 3-16 Automatic mounting(SMT) is not acceptable.

## 2. Storage Conditions:

To avoid damaging the performance and solderability, be sure to observe the following points

- 3-1 Please store the products in room where the temperature / humidity is stable.  
And avoid such places where there are large temperature changes.  
Please store the products under the following conditions :  
Temperature : -10 to +40 °C  
Humidity : 10 to 85% R.H.
- 3-2 Expire date (Shelf life) of the products is 6 months after delivery under the conditions of a sealed and an unopened package. Please use the products within 6 months after delivery.
- 3-3 Please do not store the products in a chemical atmosphere (Acids, Alkali, Bases, Organic gas, Sulfides and so on), because the characteristics may be reduced in quality, and/or be degraded in the solder-ability due to the storage in a chemical atmosphere.
- 3-4 Please do not put the products directly on the floor without anything under them to avoid damp places and/or dusty places.
- 3-5 Please do not store the products in the places such as : in a damp heated place, in a place where direct sunlight comes in, in place applying vibrations.
- 3-6 Please use the products immediately after the package is opened, because the characteristics may be reduced in quality, and/or be degraded in the solder-ability due to storage under the poor condition.
- 3-7 Please do not drop the products to avoid cracking of ceramic element.

## 3. Cautions

- 3-1 Please make sure that your product has been evaluated in view of your specifications with our device being mounted to your product.
- 3-2 Products are designed to work for electronic products under normal environmental conditions (ambient temperature, humidity and pressure). However, if the product is used under the following circumstances, it may decrease performance, damage product and leakage of electricity, and abnormal temperature may occur.
  - In an atmosphere containing corrosive gas ( Cl<sub>2</sub>, NH<sub>3</sub>, SO<sub>x</sub>, NO<sub>x</sub> etc.).
  - In an atmosphere containing combustible and volatile gases.
  - In a dusty environment.
  - Direct sunlight
  - Water splashing place.
  - Humid place where water condenses.
  - In a freezing environment.



3-3 Please make sure that your product has been evaluated and confirmed from the aspect of the fitness for the specifications of our product when our product is mounted to your product. All the items and parameters in this product specification/datasheet/catalog have been prescribed on the premise that our product is used for the purpose, under the condition and in the environment specified in this specification. You are requested not to use our product deviating from the condition and the environment specified in this specification.

3-4 If product malfunctions may result in serious damage, including that to human life, sufficient fail-safe measures must be taken, including the following:  
(1) Installation of protection circuits or other protective device to improve system safety  
(2) Installation of redundant circuits in the case of single-circuit failure

Especially when the product shall be used in medical system, please build a system which ensures the safety for human body with an apparatus, the device except this product.

If Microblower is used for medical applications, Murata requires a special contract to cover the use in the medical application to be agreed before start of mass production.

3-5 The Microblower cannot be used for automobile applications (including accessories). Do not use this product for automobiles

3-6 Customer acknowledges that Murata will, if requested by you, conduct a failure analysis for defect or alleged defect of Products only at the level required for consumer grade Products, and thus such analysis may not always be available or be in accordance with your request (for example, in cases where the defect was caused by components in Products supplied to Murata from a third party)

3-7 Please note that the only warranty that we provide regarding the products is its conformance to the specifications provided herein. Accordingly, we shall not be responsible for any defects in products or equipment incorporating such products, which are caused under the conditions other than those specified in this specification.

3-8 We expressly prohibit you from analyzing, breaking, Reverse-Engineering, remodeling altering, and reproducing our product. Our product cannot be used for the product which is prohibited from being manufactured, used, and sold by the regulations and laws in the world.

3-9 We do not warrant or represent that any license, either express or implied, is granted under any our patent right, copyright, mask work right, or our other intellectual property right relating to any combination, machine, or process in which our products or services are used. Information provided by us regarding third-party products or services does not constitute a license from us to use such products or services or a warranty or endorsement thereof. Use of such information may require a license from a third party under the patents or other intellectual property of the third party, or a license from us under our patents or other intellectual proper

3-10 Please do not use our products, our technical information and other data provided by us for the purpose of developing of mass-destruction weapons and the purpose of military use. Moreover, you must comply with "foreign exchange and foreign trade law", the "U.S. export administration regulations", etc

#### 4. Limitation of applications

The products listed in the specification (hereinafter the product(s) is called as the "Product(s)") are designed and manufactured for applications specified in the specification. (hereinafter called as the "Specific Application").

We shall not warrant anything in connection with the Products including fitness, performance, adequateness, safety, or quality, in the case of applications listed in from (1) to (11) written at the end of this precautions, which may generally require high performance, function, quality, management of production or safety. Therefore, the Product shall be applied in compliance with the specific application.

WE DISCLAIM ANY LOSS AND DAMAGES ARISING FROM OR IN CONNECTION WITH THE PRODUCTS INCLUDING BUT NOT LIMITED TO THE CASE SUCH LOSS AND DAMAGES CAUSED BY THE UNEXPECTED ACCIDENT, IN EVENT THAT (i) THE PRODUCT IS APPLIED FOR THE PURPOSE WHICH IS NOT SPECIFIED AS THE SPECIFIC APPLICATION FOR THE PRODUCT, AND/OR (ii) THE PRODUCT IS APPLIED FOR ANY FOLLOWING APPLICATION PURPOSES FROM (1) TO (11) (EXCEPT THAT SUCH APPLICATION PURPOSE IS UNAMBIGUOUSLY SPECIFIED AS SPECIFIC APPLICATION FOR THE PRODUCT IN OUR CATALOG SPECIFICATION FORMS, DATASHEETS, OR OTHER DOCUMENTS OFFICIALLY ISSUED BY US\*).

(1) Aircraft equipment

(2) Aerospace equipment

(3) Undersea equipment

(4) Power plant control equipment

(5) Medical equipment

(6) Transportation equipment

(7) Traffic control equipment

(8) Disaster prevention/security equipment

(9) Industrial data-processing equipment

(10) Combustion/explosion control equipment

(11) Equipment with complexity and/or required reliability equivalent to the applications listed in the above.

For exploring information of the Products which will be compatible with the particular purpose other than those specified in **the specification**, please contact our sales offices, distribution agents, or trading companies with which you make a deal, or via our web contact form.

Contact form: <https://www.murata.com/contactform>

\*We may design and manufacture particular Products for applications listed in (1) to (11). Provided that, in such case we shall unambiguously specify such Specific Application in **the specification** without any exception. Therefore, any other documents and/or performances, whether exist or non-exist, shall not be deemed as the evidence to imply that we accept the applications listed in (1) to (11).

#### 5. Note

Product specifications are subject to change or our products in it may be discontinued without advance notice.

This catalog is for reference only and not an official product specification document, therefore, please review and approve our official product specification before ordering this product.

(Reference material) Recommended circuit diagram and Maximum driving voltage

DC: 11~20V

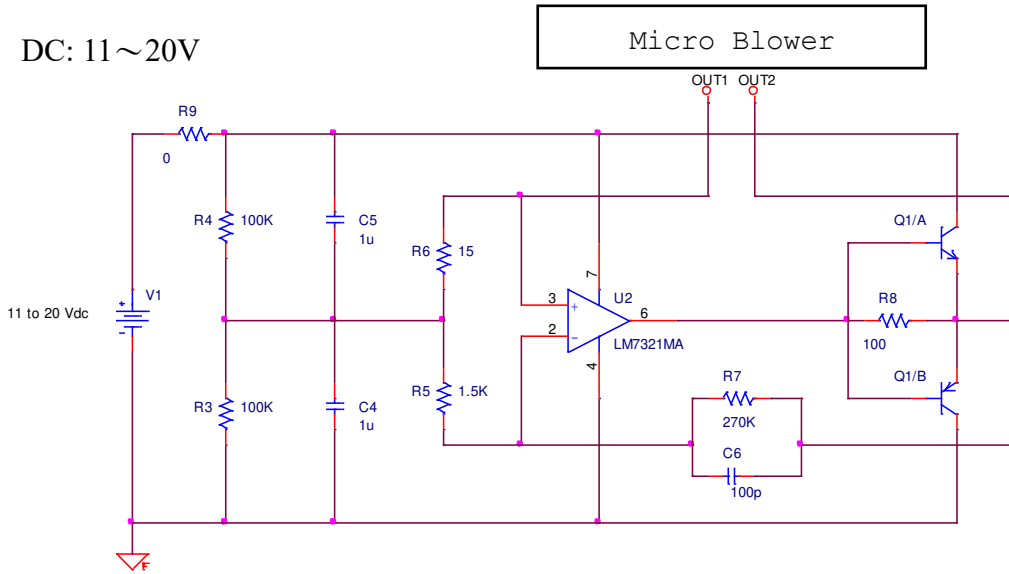

(Parts list)

Code	Name	P/N	Manufacturer
U2	GBW=20MHz Rail to Rail OP amp	LM7321MA	National Semiconductor
Q1	Transistor (PNP/NPN) Ic=500mA	HN1B04F	Toshiba Semiconductor & storage products company
R3,R4	Chip resistor 100kΩ 0.1W	RK73B1JTDD104J	KOA
R5	Chip resistor 1.5kΩ 0.1W	RK73B1JTDD152J	KOA
R6	Chip resistor 15Ω 0.1W	RK73B1JTDD150J	KOA
R7	Chip resistor 270kΩ 0.1W	RK73B1JTDD274J	KOA
R8	Chip resistor 100Ω 0.1W Chip resistor	RK73B1JTDD101J	KOA
R9	Jumper chip	RK73Z1JTDD	KOA
C4,C5	Chip Ceramic capacitor 1μF	GRM188R71E105KA12D	Murata Manufacturing Co., Ltd.
C6	Chip Ceramic capacitor 100pF	GRM1882C1H101JA01D	Murata Manufacturing Co., Ltd.

Change parts by EOL / NRND

Code	Name	P/N	Manufacturer
Q1	Transistor (PNP/NPN) Ic=500mA	HN1B04F ↓ PBSS4260PANP	Toshiba Semiconductor & storage products company ↓ NXP Semiconductor
C4,C5	Chip Ceramic capacitor 1μF	GRM188R71E105KA12D ↓ GRM155R61E105KA12D	Murata Manufacturing Co., Ltd.
C6	Chip Ceramic capacitor 100pF	GRM1882C1H101JA01D ↓ GRM1552C1H101JA01D	Murata Manufacturing Co., Ltd.
C6	Chip Ceramic capacitor 100pF	GRM1552C1H101JA01D ↓ GRM0332C1H101JA01D	Murata Manufacturing Co., Ltd.

Maximum driving voltage

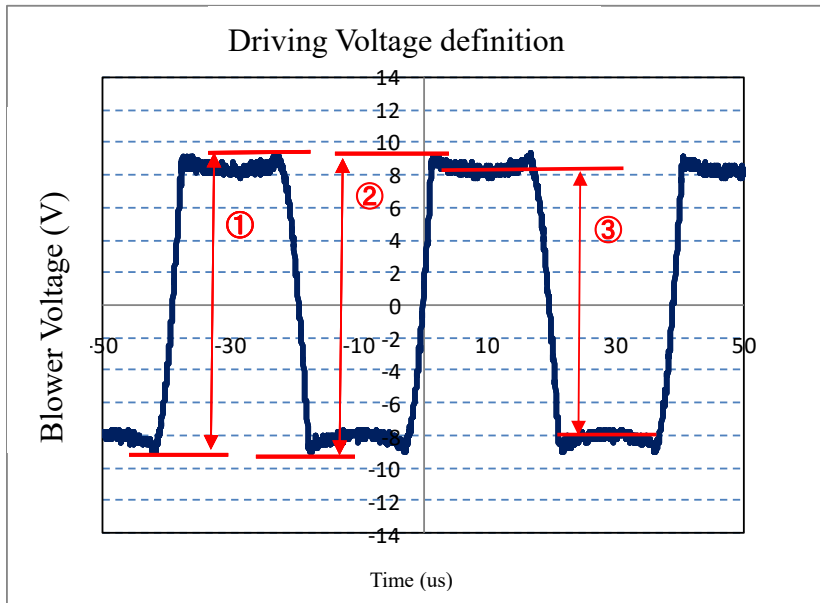

On above wave form, please set each voltage up as the less value than described below.

- ① 19.0Vpp
- ② 19.0Vpp
- ③ 18.5Vpp

Absolute maximum rating voltage

Please set the power-supply voltage for OP amp up as less value than 30Vdc.  
 There is a possibility that Microblower breaks if you supply the voltage over than this value momentarily.

Notes) The wave form is outputted if you supply the DC (from 11V to 20V) to Vpp.  
 The amplitude voltage depends on the input voltage, and please adjust the power-supply voltage within the range of rated voltage.