

REVISIONS			
LTR	DESCRIPTION	DATE	APPROVED
C	REVISED AND REDRAWN ON CAD PER DCR NO.AD97010	4/11/97	GMR

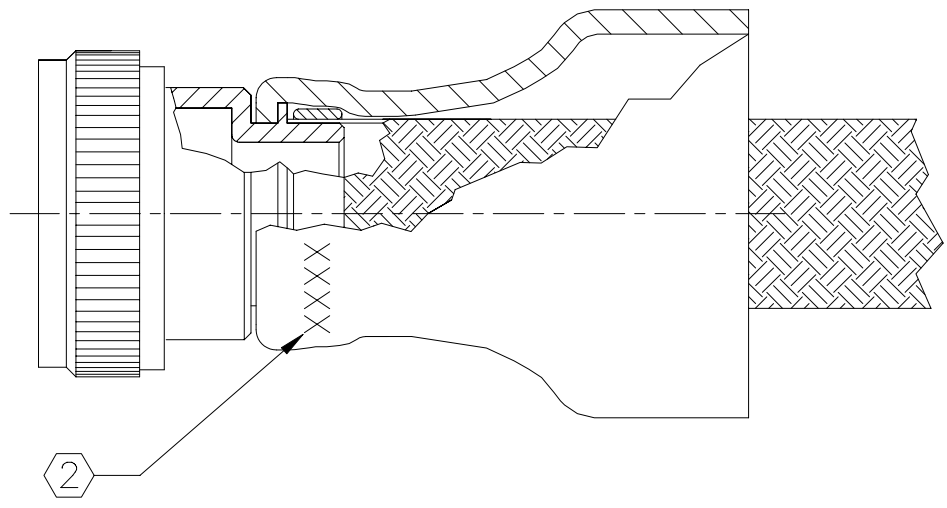

STRAIGHT ADAPTER
WITH BOOT ATTACHED

NOTES:

1. FOR ADDITIONAL DIMENSIONS, ORDERING INFORMATION AND MODIFICATIONS, SEE CH00-0250-010.
- ② ADAPTER/BOOT ASSEMBLY TO BE PERMANENTLY MARKED IN AREA SHOWN WITH CODE IDENT. NO. AND PART NO. (E.G. 06090-HWS-38-16) IN ACCORDANCE WITH MIL-STD-130.
- ③ ADAPTER MATES TO MIL-C-38999 SERIES I (17 SHELL) AND SERIES II (16 SHELL) MS27474-T16 CONNECTORS.
4. ADAPTER MATERIAL: ALUMINUM ALLOY PER QQ-A-225.
5. ADAPTER FINISH: ELECTROLESS NICKEL PER MIL-C-26074, CLASS 3 OR 4, GRADE A.

**If this document is printed it becomes uncontrolled.
Check with document control for latest revision.**

SPECIFICATION CONTROL DRAWING

UNLESS OTHERWISE SPECIFIED
DIMENSIONS ARE IN INCHES.
METRIC DIMENSIONS ARE
IN BRACKETS.

DECIMALS
 .XXX ± — [mm]
 .XX ± — [mm]
 .X ± — [mm]

ANGLES
 .X ± —

DRAWN G. ROSITANO	DATE 4/8/97
CHECKED	DATE
APPROVED	DATE
APPROVED W.C. GAY	DATE 4/11/97
CAD NAME ADAPTERS\HWS38-1	

Raychem	RAYCHEM CORPORATION 300 CONSTITUTION DRIVE MENLO PARK, CALIFORNIA 94025
	TITLE

ADAPTER, SHIELD, STRAIGHT
WITH HEAT SHRINKABLE BOOT

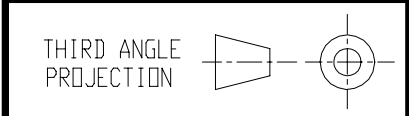

SIZE A	CODE IDENT. NO. 06090	DWG. NO. HWS-38-16-S	REV C
DO NOT SCALE THIS DWG		SHEET 1 OF 2	

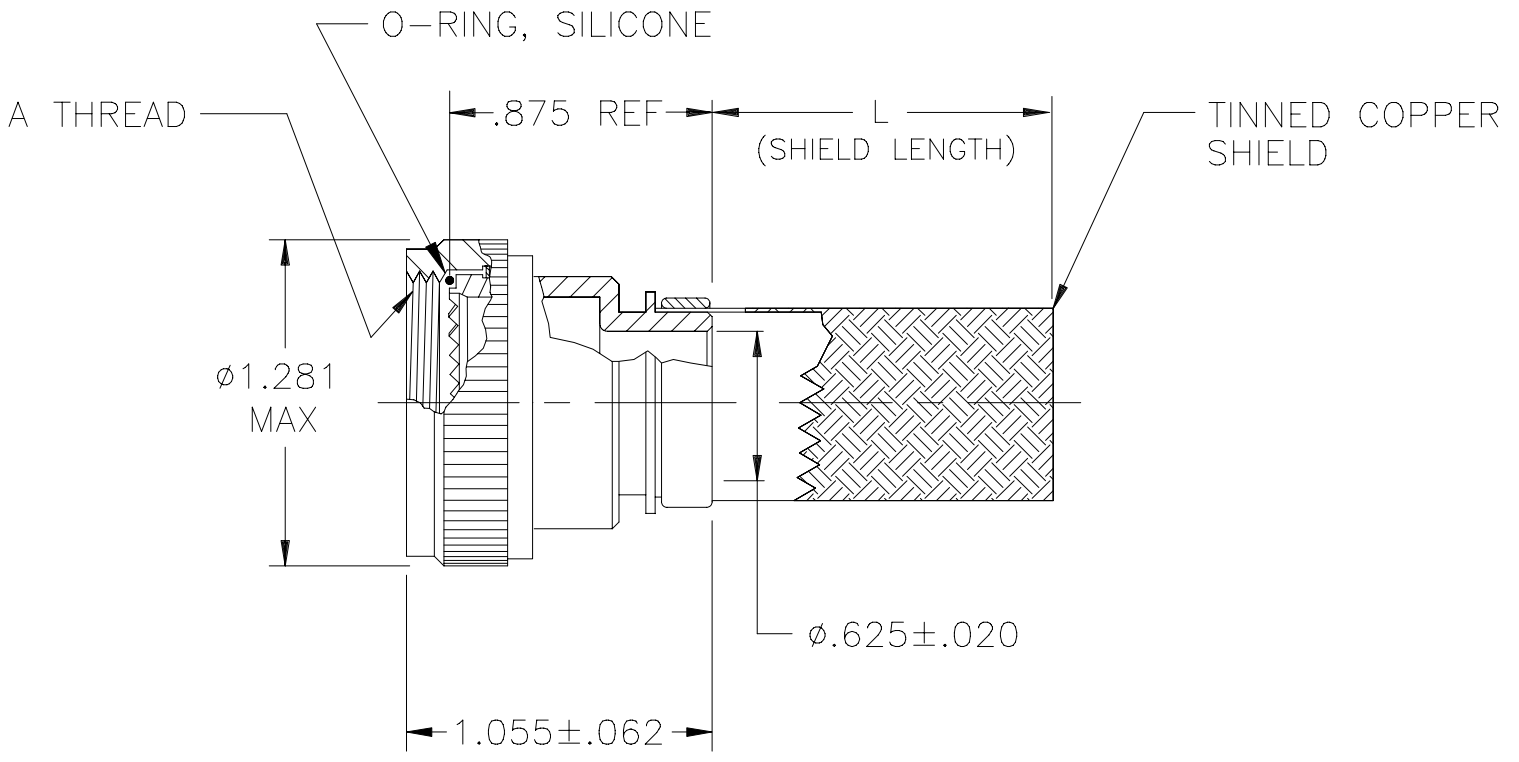

RAYCHEM ADAPTER
(RAYCHEM BOOT OMITTED FOR CLARITY)

RAYCHEM PART NUMBER	SHELL SIZE $\text{\textcircled{3}}$		RAYCHEM ADAPTER PART NUMBER	RAYCHEM BOOT PART NUMBER	L MIN	A R.H. THREAD CLASS 2B
	SER I	SER II				
HWS-38-16-S	17	16	204M016-19D10	202D232-4	6	.938-20 UNEF
HWS-38-16-S-12	17	16	204M016-19D1012	202D232-4	12	.938-20 UNEF
HWS-38-16-S-48	17	16	204M016-19D1048	202D232-4	48	.938-20 UNEF

If this document is printed it becomes uncontrolled.
Check with document control for latest revision.

SIZE	CODE IDENT. NO.	DWG. NO.	REV
A	06090	HWS-38-16-S	C
DO NOT SCALE THIS DWG		CAD NAME ADAPTERS\HWS38-2	SHEET 2 OF 2