

XMC1400 AA-Step

Microcontroller Series
for Industrial Applications

XMC1000 Family

ARM[®] Cortex[®]-M0
32-bit processor core

Data Sheet

V1.4 2017-11

Edition 2017-11

**Published by
Infineon Technologies AG
81726 Munich, Germany**

**© 2017 Infineon Technologies AG
All Rights Reserved.**

Legal Disclaimer

The information given in this document shall in no event be regarded as a guarantee of conditions or characteristics. With respect to any examples or hints given herein, any typical values stated herein and/or any information regarding the application of the device, Infineon Technologies hereby disclaims any and all warranties and liabilities of any kind, including without limitation, warranties of non-infringement of intellectual property rights of any third party.

Information

For further information on technology, delivery terms and conditions and prices, please contact the nearest Infineon Technologies Office (www.infineon.com).

Warnings

Due to technical requirements, components may contain dangerous substances. For information on the types in question, please contact the nearest Infineon Technologies Office.

Infineon Technologies components may be used in life-support devices or systems only with the express written approval of Infineon Technologies, if a failure of such components can reasonably be expected to cause the failure of that life-support device or system or to affect the safety or effectiveness of that device or system. Life support devices or systems are intended to be implanted in the human body or to support and/or maintain and sustain and/or protect human life. If they fail, it is reasonable to assume that the health of the user or other persons may be endangered.

XMC1400 AA-Step

Microcontroller Series
for Industrial Applications

XMC1000 Family

ARM[®] Cortex[®]-M0
32-bit processor core

Data Sheet

V1.4 2017-11

XMC1400 Data Sheet

Revision History: V1.4 2017-11

Previous Versions:

V1.3 2016-10

V1.2 2016-08

V1.1 2016-06

V1.0 2016-02

V0.3 2015-10

| Page | Subjects |
|--|---|
| 11 | Added XMC1404-Q040 variants in Table 1.1 |
| 14 | Added XMC1404-Q040 variants in Table 1.3 |
| 16 | Added XMC1404-Q040 variants in Table 1.4 |
| V1.3 2016-10 | |
| 43 , 44 | In Absolute Maximum Ratings renamed parameter V_{CM} to V_{INP2} , as the limitation is related to most P2 pins, also if no ACMP is available. Clarified limit to pins P2.[1,2,6:9,11] in Overload specification. |
| 14 | Corrected XMC1402-T038X0200 and XMC1402-Q048X0200 marking variants in Table 2 |
| V1.2 2016-08 | |
| many | Added XMC™ trademark |
| 11 , 14 , 16 | Added XMC1402-T038X0200, XMC1402-Q040X0200 and XMC1402-Q048X0200 marking variants |
| V1.1 2016-06 | |
| many | Added TSSOP-38-9 package |
| 11 , 14 , 16 | Added XMC1402-T038 marking variants in TSSOP-38 |
| 11 , 14 , 16 | Added XMC1403-Q040 marking variants |
| V1.0 2016-02 | |
| 10 | The device provides four USIC channels. |
| 11 | XMC1401 devices available for max. ambient temperature of 85°C. |
| 34 | Reformatted pinout table. |
| 59 | Updated footnote to the definition of the start-up times of OSC_XTAL and RTC_XTAL oscillators. |

XMC1400 Data Sheet

Revision History: V1.4 2017-11

| | |
|-----------|---|
| 74 | Added Δf_{LT} parameter to on-chip oscillators DCO1 and DCO2. |
| 86 | Updated package outline drawings. |

Trademarks

C166™, TriCore™, XMC™ and DAVE™ are trademarks of Infineon Technologies AG. ARM®, ARM Powered®, Cortex®, Thumb® and AMBA® are registered trademarks of ARM, Limited.

CoreSight™, ETM™, Embedded Trace Macrocell™ and Embedded Trace Buffer™ are trademarks of ARM, Limited.

We Listen to Your Comments

Is there any information in this document that you feel is wrong, unclear or missing? Your feedback will help us to continuously improve the quality of this document. Please send your proposal (including a reference to this document) to:

mcdocu.comments@infineon.com



Table of Contents

| | | |
|----------|--|-----------|
| 1 | Summary of Features | 9 |
| 1.1 | Device Overview | 11 |
| 1.2 | Ordering Information | 12 |
| 1.3 | Device Types | 14 |
| 1.4 | Chip Identification Number | 16 |
| 2 | General Device Information | 19 |
| 2.1 | Logic Symbols | 19 |
| 2.2 | Pin Configuration and Definition | 23 |
| 2.2.1 | Package Pin Summary | 27 |
| 2.2.2 | Port Pin for Boot Modes | 31 |
| 2.2.3 | Port I/O Function Description | 32 |
| 2.2.4 | Hardware Controlled I/O Function Description | 33 |
| 3 | Electrical Parameter | 42 |
| 3.1 | General Parameters | 42 |
| 3.1.1 | Parameter Interpretation | 42 |
| 3.1.2 | Absolute Maximum Ratings | 43 |
| 3.1.3 | Pin Reliability in Overload | 44 |
| 3.1.4 | Operating Conditions | 46 |
| 3.2 | DC Parameters | 47 |
| 3.2.1 | Input/Output Characteristics | 47 |
| 3.2.2 | Analog to Digital Converters (ADC) | 51 |
| 3.2.3 | Out of Range Comparator (ORC) Characteristics | 55 |
| 3.2.4 | Analog Comparator Characteristics | 57 |
| 3.2.5 | Temperature Sensor Characteristics | 58 |
| 3.2.6 | Oscillator Pins | 59 |
| 3.2.7 | Power Supply Current | 63 |
| 3.2.8 | Flash Memory Parameters | 69 |
| 3.3 | AC Parameters | 71 |
| 3.3.1 | Testing Waveforms | 71 |
| 3.3.2 | Power-Up and Supply Threshold Characteristics | 72 |
| 3.3.3 | On-Chip Oscillator Characteristics | 74 |
| 3.3.4 | Serial Wire Debug Port (SW-DP) Timing | 75 |
| 3.3.5 | SPD Timing Requirements | 76 |
| 3.3.6 | Peripheral Timings | 77 |
| 3.3.6.1 | Synchronous Serial Interface (USIC SSC) Timing | 77 |
| 3.3.6.2 | Inter-IC (IIC) Interface Timing | 80 |
| 3.3.6.3 | Inter-IC Sound (IIS) Interface Timing | 82 |
| 4 | Package and Reliability | 84 |
| 4.1 | Package Parameters | 84 |

Table of Contents

| | | |
|-------|--------------------------------------|----|
| 4.1.1 | Thermal Considerations | 84 |
| 4.2 | Package Outlines | 86 |
| 5 | Quality Declaration | 89 |

About this Document

This Data Sheet is addressed to embedded hardware and software developers. It provides the reader with detailed descriptions about the ordering designations, available features, electrical and physical characteristics of the XMC1400 series devices.

The document describes the characteristics of a superset of the XMC1400 series devices. For simplicity, the various device types are referred to by the collective term XMC1400 throughout this document.

XMC1000 Family User Documentation

The set of user documentation includes:

- **Reference Manual**
 - describes the functionality of the superset of devices.
- **Data Sheets**
 - list the complete ordering designations, available features and electrical characteristics of derivative devices.
- **Errata Sheets**
 - list deviations from the specifications given in the related Reference Manual or Data Sheets. Errata Sheets are provided for the superset of devices.

Attention: Please consult all parts of the documentation set to attain consolidated knowledge about your device.

Application related guidance is provided by **Users Guides** and **Application Notes**.

Please refer to <http://www.infineon.com/xmc1000> to get access to the latest versions of those documents.

1 Summary of Features

The XMC1400 devices are members of the XMC1000 Family of microcontrollers based on the ARM Cortex-M0 processor core. The XMC1400 series addresses the real-time control needs of motor control and digital power conversion. It also features peripherals for LED Lighting applications and Human-Machine Interface (HMI).

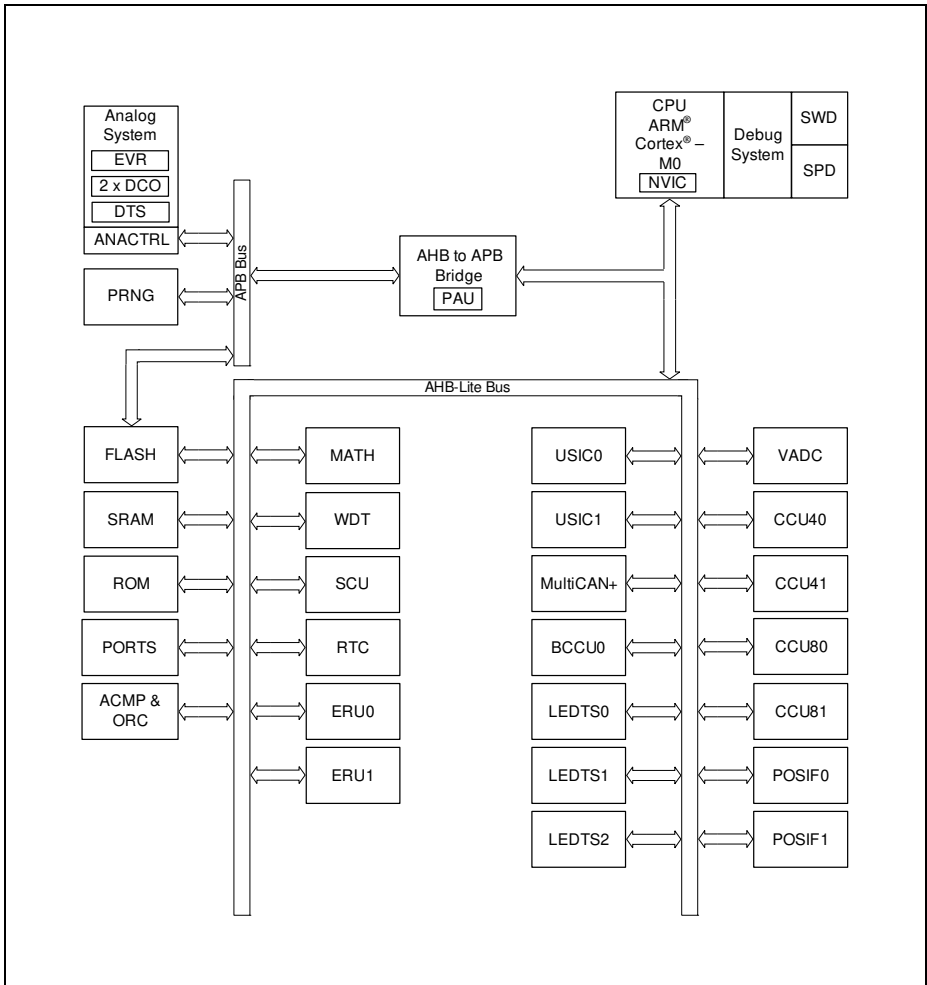

Figure 1 Block Diagram

Features

CPU subsystem

- 32-bit ARM Cortex-M0 CPU Core
 - 0.84 DMIPS/MHz (Dhrystone 2.1) at 48 MHz
- Nested Vectored Interrupt Controller
- 64 interrupt nodes
- MATH coprocessor
 - 24-bit trigonometric calculation (CORDIC)
 - 32-bit divide operation
- 2x4 channels ERU for event interconnections

On-Chip Memories

- 8 Kbyte ROM
- 16 Kbyte SRAM (with parity)
- up to 200 Kbyte Flash (with ECC)

Supply, Reset and Clock

- 1.8 V to 5.5 V supply with power on reset and brownout detector
- On-chip clock monitor
- External crystal oscillator support (32 kHz and 4 to 20 MHz)
- Internal slow and fast oscillators without the need of PLL

System Control

- Window watchdog
- Real time clock module
- Pseudo random number generator

Communication Peripherals

- Four USIC channels, usable as
 - UART (up to 12 Mb/s)
 - single-SPI (up to 12 Mb/s)
 - double-SPI (up to 2 × 12 Mb/s)
 - quad-SPI (up to 4 × 12 Mb/s)
 - IIC (up to 400 kb/s)
 - IIS (up to 12 Mb/s)
 - LIN interfaces (20kb/s)
- LEDTS in Human-Machine interface
 - up to 24 touch pads
 - drive up to 144 LEDs
- MultiCAN+, Full-CAN/Basic-CAN with 2 nodes, 32 message objects (up to 1 MBaud)

Analog Frontend Peripherals

- A/D Converters (up to 12 analog inputs)
 - 2 sample and hold stages
 - fast 12-bit ADC (up to 1.1 MS/s), adjustable gain
 - 0 V to 5.5 V input range
- Up to 8 channels out of range comparators
- Up to 4 fast analog comparators
- Temperature Sensor

Industrial Control Peripherals

- 2x4 16-bit 96 MHz CCU4 timers for signal monitoring and PWM
- 2x4 16-bit 96 MHz CCU8 timers for complex PWM, complementary high/low side switches and multi phase control
- 2x POSIF for hall and quadrature encoders, motor positioning
- 9 channel BCCU (brightness and color control) for LED lighting applications

Up to 56 Input/Output Ports

- 1.8 V to 5.5 V capable
- up to 8 high current pads (50 mA sink)

On-Chip Debug Support

- 4 breakpoints, 2 watchpoints
- ARM serial wire debug, single-pin debug interfaces

Programming Support

- Single-pin bootloader
- Secure bootstrap loader SBSL (optional)

Packages

- TSSOP-38 (9.7 × 6.4 mm²)
- VQFN-40/48/64 (5×5/7×7/8×8 mm²)
- LQFP-64 (12 × 12 mm²)

Tools

- Free DAVE™ toolchain with low level drivers and apps

1.1 Device Overview

The following table lists the available features per device type for the XMC1400 series.

Table 1 Features of XMC1400 Device Types¹⁾

| Features | XMC1401-Q048 | XMC1401-F064 | XMC1402-T038 | XMC1402-Q040 | XMC1402-Q048 | XMC1402-Q064 | XMC1402-F064 | XMC1403-Q040 | XMC1403-Q048 | XMC1403-Q064 | XMC1404-Q040 | XMC1404-Q048 | XMC1404-Q064 | XMC1404-F064 |
|---------------------------------|--------------------|--------------|---------------------|--------------|--------------|--------------|--------------|--------------|--------------|--------------|--------------|--------------|--------------|--------------|
| CPU frequency | 48 MHz | | | | | | | | | | | | | |
| Operating temperature (ambient) | -40 to 85 °C | | -40 to 105 °C | | | | | | | | | | | |
| Operating voltage | 1.8 V to 5.5 V | | | | | | | | | | | | | |
| Flash options (Kbytes) | 64, 128 64, 128 | | 32, 64, 128, 200 | | | 64, 128, 200 | | | | | | | | |
| SRAM (Kbytes) | 16 | 16 | 16 | 16 | 16 | 16 | 16 | 16 | 16 | 16 | 16 | 16 | 16 | 16 |
| MATH | - | - | 1 | 1 | 1 | 1 | 1 | - | - | - | 1 | 1 | 1 | 1 |
| Industrial Control | CCU4 | 2 | 2 | 2 | 2 | 2 | 2 | 2 | 2 | 2 | 2 | 2 | 2 | 2 |
| | CCU8 | - | - | 2 | 2 | 2 | 2 | 2 | - | - | - | 2 | 2 | 2 |
| | POSIF | - | - | 1 | 1 | 2 | 2 | 2 | - | - | - | 1 | 2 | 2 |
| | BCCU | - | - | 1 | 1 | 1 | 1 | 1 | - | - | - | 1 | 1 | 1 |

Table 1 Features of XMC1400 Device Types¹⁾ (cont'd)

| Features | | XMC1401-Q048 | XMC1401-F064 | XMC1402-T038 | XMC1402-Q040 | XMC1402-Q048 | XMC1402-Q064 | XMC1402-F064 | XMC1403-Q040 | XMC1403-Q048 | XMC1403-Q064 | XMC1404-Q040 | XMC1404-Q048 | XMC1404-Q064 | XMC1404-F064 |
|---------------|-------------------------------|--------------|--------------|--------------|--------------|--------------|--------------|--------------|--------------|--------------|--------------|--------------|--------------|--------------|--------------|
| Communication | USIC (modules / channels) | 2 / 2 | 2 / 2 | 2 / 2 | 2 / 2 | 2 / 2 | 2 / 2 | 2 / 2 | 2 / 2 | 2 / 2 | 2 / 2 | 2 / 2 | 2 / 2 | 2 / 2 | 2 / 2 |
| | LEDTS | 3 | 3 | - | - | - | - | - | - | - | - | 2 | 3 | 3 | 3 |
| | MultiCA N+ (nodes / MOs) | - | - | - | - | - | - | - | 2 / 32 | 2 / 32 | 2 / 32 | 2 / 32 | 2 / 32 | 2 / 32 | 2 / 32 |
| Analog | ADC (kernels / analog inputs) | 2 / 12 | 2 / 12 | 2 / 12 | 2 / 12 | 2 / 12 | 2 / 12 | 2 / 12 | 2 / 12 | 2 / 12 | 2 / 12 | 2 / 12 | 2 / 12 | 2 / 12 | 2 / 12 |
| | ACMP | - | - | 3 | 3 | 4 | 4 | 4 | - | - | - | 3 | 4 | 4 | 4 |
| GPIOs | | 34 | 48 | 26 | 27 | 34 | 48 | 48 | 27 | 34 | 48 | 27 | 34 | 48 | 48 |
| GPIs | | 8 | 8 | 8 | 8 | 8 | 8 | 8 | 8 | 8 | 8 | 8 | 8 | 8 | 8 |
| Packages | | VQFN-48 | LQFP-64 | TSSOP-38 | VQFN-40 | VQFN-48 | VQFN-64 | LQFP-64 | VQFN-40 | VQFN-48 | VQFN-64 | VQFN-40 | VQFN-48 | VQFN-64 | LQFP-64 |

1) Features that are not included in this table are available in all the derivatives

1.2 Ordering Information

The ordering code for an Infineon microcontroller provides an exact reference to a specific product. The code "XMC1<DDD>-<Z><PPP><T><FFFF>" identifies:

- <DDD> the derivatives function set
- <Z> the package variant
 - T: TSSOP
 - Q: VQFN
 - F: LQFP

- <PPP> package pin count
- <T> the temperature range:
 - F: -40°C to 85°C
 - X: -40°C to 105°C
- <FFFF> the Flash memory size in Kbytes.

For ordering codes for the XMC1400 please contact your sales representative or local distributor.

This document describes several derivatives of the XMC1400 series, some descriptions may not apply to a specific product. Please see [Table 2](#).

For simplicity the term **XMC1400** is used for all derivatives throughout this document.

1.3 Device Types

These device types are available and can be ordered through Infineon's direct and/or distribution channels.

Table 2 Synopsis of XMC1400 Device Types

| Derivative | Package | Flash Kbytes |
|-------------------|-------------|--------------|
| XMC1401-Q048F0064 | PG-VQFN-48 | 64 |
| XMC1401-Q048F0128 | PG-VQFN-48 | 128 |
| XMC1401-F064F0064 | PG-LQFP-64 | 64 |
| XMC1401-F064F0128 | PG-LQFP-64 | 128 |
| XMC1402-T038X0032 | PG-TSSOP-38 | 32 |
| XMC1402-T038X0064 | PG-TSSOP-38 | 64 |
| XMC1402-T038X0128 | PG-TSSOP-38 | 128 |
| XMC1402-T038X0200 | PG-TSSOP-38 | 200 |
| XMC1402-Q040X0032 | PG-VQFN-40 | 32 |
| XMC1402-Q040X0064 | PG-VQFN-40 | 64 |
| XMC1402-Q040X0128 | PG-VQFN-40 | 128 |
| XMC1402-Q040X0200 | PG-VQFN-40 | 200 |
| XMC1402-Q048X0032 | PG-VQFN-48 | 32 |
| XMC1402-Q048X0064 | PG-VQFN-48 | 64 |
| XMC1402-Q048X0128 | PG-VQFN-48 | 128 |
| XMC1402-Q048X0200 | PG-VQFN-48 | 200 |
| XMC1402-Q064X0064 | PG-VQFN-64 | 64 |
| XMC1402-Q064X0128 | PG-VQFN-64 | 128 |
| XMC1402-Q064X0200 | PG-VQFN-64 | 200 |
| XMC1402-F064X0064 | PG-LQFP-64 | 64 |
| XMC1402-F064X0128 | PG-LQFP-64 | 128 |
| XMC1402-F064X0200 | PG-LQFP-64 | 200 |
| XMC1403-Q040X0064 | PG-VQFN-40 | 64 |
| XMC1403-Q040X0128 | PG-VQFN-40 | 128 |
| XMC1403-Q040X0200 | PG-VQFN-40 | 200 |
| XMC1403-Q048X0064 | PG-VQFN-48 | 64 |
| XMC1403-Q048X0128 | PG-VQFN-48 | 128 |

Table 2 Synopsis of XMC1400 Device Types (cont'd)

| Derivative | Package | Flash Kbytes |
|-------------------|----------------|---------------------|
| XMC1403-Q048X0200 | PG-VQFN-48 | 200 |
| XMC1403-Q064X0064 | PG-VQFN-64 | 64 |
| XMC1403-Q064X0128 | PG-VQFN-64 | 128 |
| XMC1403-Q064X0200 | PG-VQFN-64 | 200 |
| XMC1404-Q040X0064 | PG-VQFN-40 | 64 |
| XMC1404-Q040X0128 | PG-VQFN-40 | 128 |
| XMC1404-Q040X0200 | PG-VQFN-40 | 200 |
| XMC1404-Q048X0064 | PG-VQFN-48 | 64 |
| XMC1404-Q048X0128 | PG-VQFN-48 | 128 |
| XMC1404-Q048X0200 | PG-VQFN-48 | 200 |
| XMC1404-Q064X0064 | PG-VQFN-64 | 64 |
| XMC1404-Q064X0128 | PG-VQFN-64 | 128 |
| XMC1404-Q064X0200 | PG-VQFN-64 | 200 |
| XMC1404-F064X0064 | PG-LQFP-64 | 64 |
| XMC1404-F064X0128 | PG-LQFP-64 | 128 |
| XMC1404-F064X0200 | PG-LQFP-64 | 200 |

1.4 Chip Identification Number

The Chip Identification Number allows software to identify the marking. It is an 8 words value with the most significant 7 words stored in Flash configuration sector 0 (CS0) at address location : 1000 0F00_H (MSB) - 1000 0F1B_H (LSB). The least significant word and most significant word of the Chip Identification Number are the value of registers DBGROMID and IDCHIP, respectively.

Table 3 XMC1400 Chip Identification Number

| Derivative | Value | Marking |
|-------------------|---|---------|
| XMC1401-Q048F0064 | 00014082 07CF00FF 1E071FF7 20006000 00000D00 00001000 00011000 10204083 _H | AA |
| XMC1401-Q048F0128 | 00014082 07CF00FF 1E071FF7 20006000 00000D00 00001000 00021000 10204083 _H | AA |
| XMC1401-F064F0064 | 000140A2 07CF00FF 1E071FF7 20006000 00000D00 00001000 00011000 10204083 _H | AA |
| XMC1401-F064F0128 | 000140A2 07CF00FF 1E071FF7 20006000 00000D00 00001000 00021000 10204083 _H | AA |
| XMC1402-T038X0032 | 00014013 07FF00FF 1E071FF7 000F900F 00000D00 00001000 00009000 10204083 _H | AA |
| XMC1402-T038X0064 | 00014013 07FF00FF 1E071FF7 000F900F 00000D00 00001000 00011000 10204083 _H | AA |
| XMC1402-T038X0128 | 00014013 07FF00FF 1E071FF7 000F900F 00000D00 00001000 00021000 10204083 _H | AA |
| XMC1402-T038X0200 | 00014013 07FF00FF 1E071FF7 000F900F 00000D00 00001000 00033000 10204083 _H | AA |
| XMC1402-Q040X0032 | 00014043 07FF00FF 1E071FF7 000F900F 00000D00 00001000 00009000 10204083 _H | AA |
| XMC1402-Q040X0064 | 00014043 07FF00FF 1E071FF7 000F900F 00000D00 00001000 00011000 10204083 _H | AA |
| XMC1402-Q040X0128 | 00014043 07FF00FF 1E071FF7 000F900F 00000D00 00001000 00021000 10204083 _H | AA |
| XMC1402-Q040X0200 | 00014043 07FF00FF 1E071FF7 000F900F 00000D00 00001000 00033000 10204083 _H | AA |
| XMC1402-Q048X0032 | 00014083 07FF00FF 1E071FF7 100F900F 00000D00 00001000 00009000 10204083 _H | AA |

Table 3 XMC1400 Chip Identification Number (cont'd)

| Derivative | Value | Marking |
|-------------------|---|----------------|
| XMC1402-Q048X0064 | 00014083 07FF00FF 1E071FF7 100F900F 00000D00 00001000 00011000 10204083 _H | AA |
| XMC1402-Q048X0128 | 00014083 07FF00FF 1E071FF7 100F900F 00000D00 00001000 00021000 10204083 _H | AA |
| XMC1402-Q048X0200 | 00014083 07FF00FF 1E071FF7 100F900F 00000D00 00001000 00033000 10204083 _H | AA |
| XMC1402-Q064X0064 | 00014093 07FF00FF 1E071FF7 100F900F 00000D00 00001000 00011000 10204083 _H | AA |
| XMC1402-Q064X0128 | 00014093 07FF00FF 1E071FF7 100F900F 00000D00 00001000 00021000 10204083 _H | AA |
| XMC1402-Q064X0200 | 00014093 07FF00FF 1E071FF7 100F900F 00000D00 00001000 00033000 10204083 _H | AA |
| XMC1402-F064X0064 | 000140A3 07FF00FF 1E071FF7 100F900F 00000D00 00001000 00011000 10204083 _H | AA |
| XMC1402-F064X0128 | 000140A3 07FF00FF 1E071FF7 100F900F 00000D00 00001000 00021000 10204083 _H | AA |
| XMC1402-F064X0200 | 000140A3 07FF00FF 1E071FF7 100F900F 00000D00 00001000 00033000 10204083 _H | AA |
| XMC1403-Q040X0064 | 00014043 07CF00FF 1E071FF7 00B00000 00000D00 00001000 00011000 10204083 _H | AA |
| XMC1403-Q040X0128 | 00014043 07CF00FF 1E071FF7 00B00000 00000D00 00001000 00021000 10204083 _H | AA |
| XMC1403-Q040X0200 | 00014043 07CF00FF 1E071FF7 00B00000 00000D00 00001000 00033000 10204083 _H | AA |
| XMC1403-Q048X0064 | 00014083 07CF00FF 1E071FF7 00B00000 00000D00 00001000 00011000 10204083 _H | AA |
| XMC1403-Q048X0128 | 00014083 07CF00FF 1E071FF7 00B00000 00000D00 00001000 00021000 10204083 _H | AA |
| XMC1403-Q048X0200 | 00014083 07CF00FF 1E071FF7 00B00000 00000D00 00001000 00033000 10204083 _H | AA |
| XMC1403-Q064X0064 | 00014093 07CF00FF 1E071FF7 00B00000 00000D00 00001000 00011000 10204083 _H | AA |
| XMC1403-Q064X0128 | 00014093 07CF00FF 1E071FF7 00B00000 00000D00 00001000 00021000 10204083 _H | AA |

Table 3 XMC1400 Chip Identification Number (cont'd)

| Derivative | Value | Marking |
|-------------------|---|----------------|
| XMC1403-Q064X0200 | 00014093 07FF00FF 1E071FF7 00B00000 00000D00 00001000 00033000 10204083 _H | AA |
| XMC1404-Q040X0064 | 00014043 07FF00FF 1E071FF7 30BFF00F 00000D00 00001000 00011000 10204083 _H | AA |
| XMC1404-Q040X0128 | 00014043 07FF00FF 1E071FF7 30BFF00F 00000D00 00001000 00021000 10204083 _H | AA |
| XMC1404-Q040X0200 | 00014043 07FF00FF 1E071FF7 30BFF00F 00000D00 00001000 00033000 10204083 _H | AA |
| XMC1404-Q048X0064 | 00014083 07FF00FF 1E071FF7 30BFF00F 00000D00 00001000 00011000 10204083 _H | AA |
| XMC1404-Q048X0128 | 00014083 07FF00FF 1E071FF7 30BFF00F 00000D00 00001000 00021000 10204083 _H | AA |
| XMC1404-Q048X0200 | 00014083 07FF00FF 1E071FF7 30BFF00F 00000D00 00001000 00033000 10204083 _H | AA |
| XMC1404-Q064X0064 | 00014093 07FF00FF 1E071FF7 30BFF00F 00000D00 00001000 00011000 10204083 _H | AA |
| XMC1404-Q064X0128 | 00014093 07FF00FF 1E071FF7 30BFF00F 00000D00 00001000 00021000 10204083 _H | AA |
| XMC1404-Q064X0200 | 00014093 07FF00FF 1E071FF7 30BFF00F 00000D00 00001000 00033000 10204083 _H | AA |
| XMC1404-F064X0064 | 000140A3 07FF00FF 1E071FF7 30BFF00F 00000D00 00001000 00011000 10204083 _H | AA |
| XMC1404-F064X0128 | 000140A3 07FF00FF 1E071FF7 30BFF00F 00000D00 00001000 00021000 10204083 _H | AA |
| XMC1404-F064X0200 | 000140A3 07FF00FF 1E071FF7 30BFF00F 00000D00 00001000 00033000 10204083 _H | AA |

2 General Device Information

This section summarizes the logic symbols and package pin configurations with a detailed list of the functional I/O mapping.

2.1 Logic Symbols

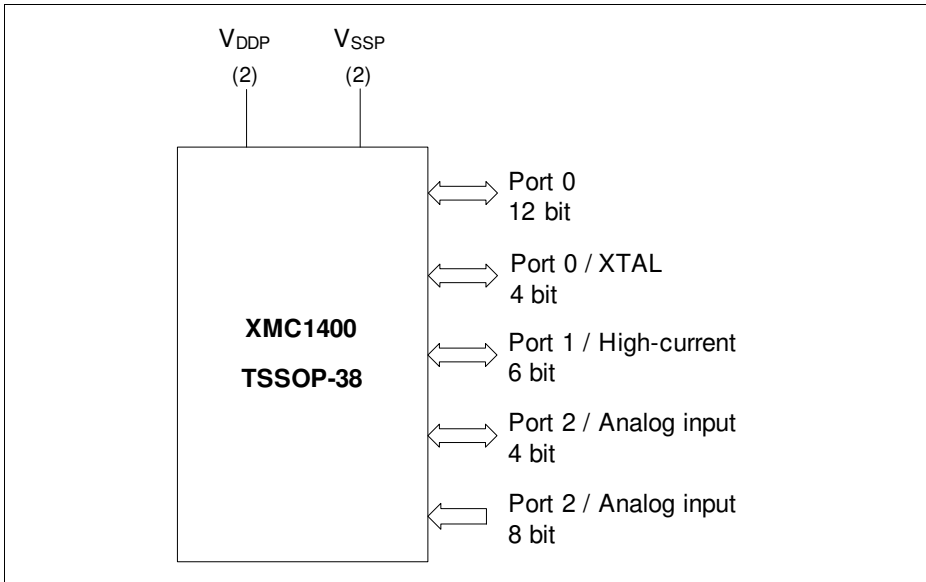

Figure 2 XMC1400 Logic Symbol for TSSOP-38-9

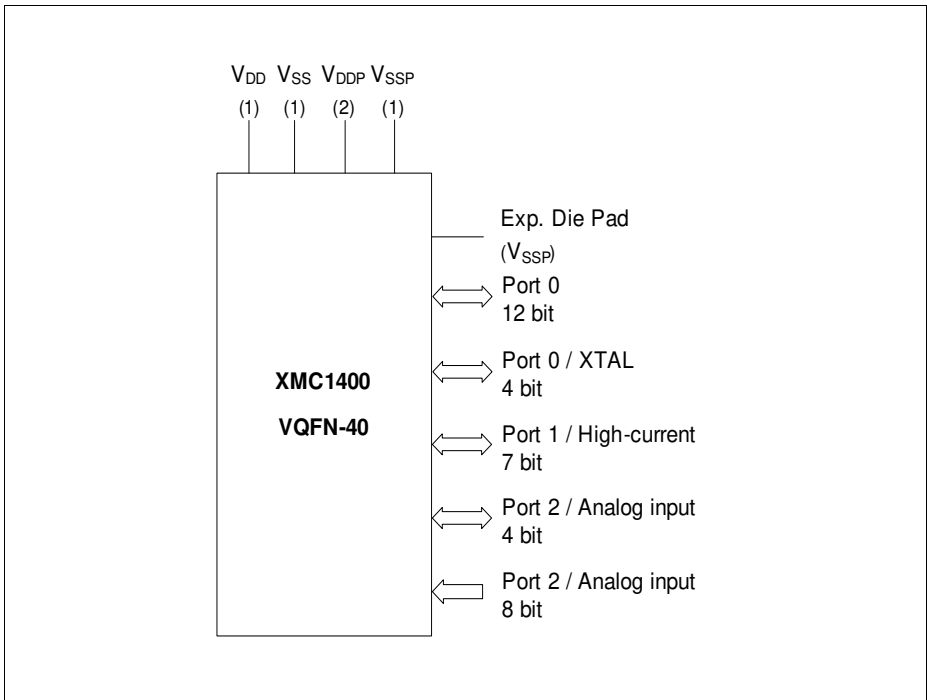

Figure 3 XMC1400 Logic Symbol for PG-VQFN-40-17

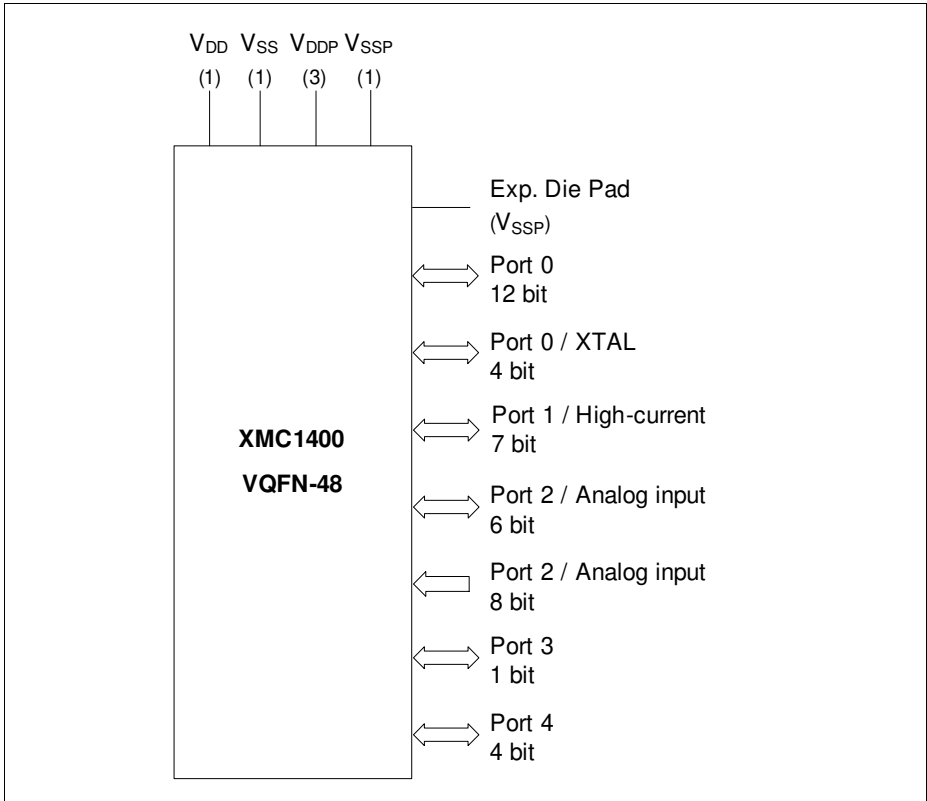

Figure 4 XMC1400 Logic Symbol for PG-VQFN-48-73

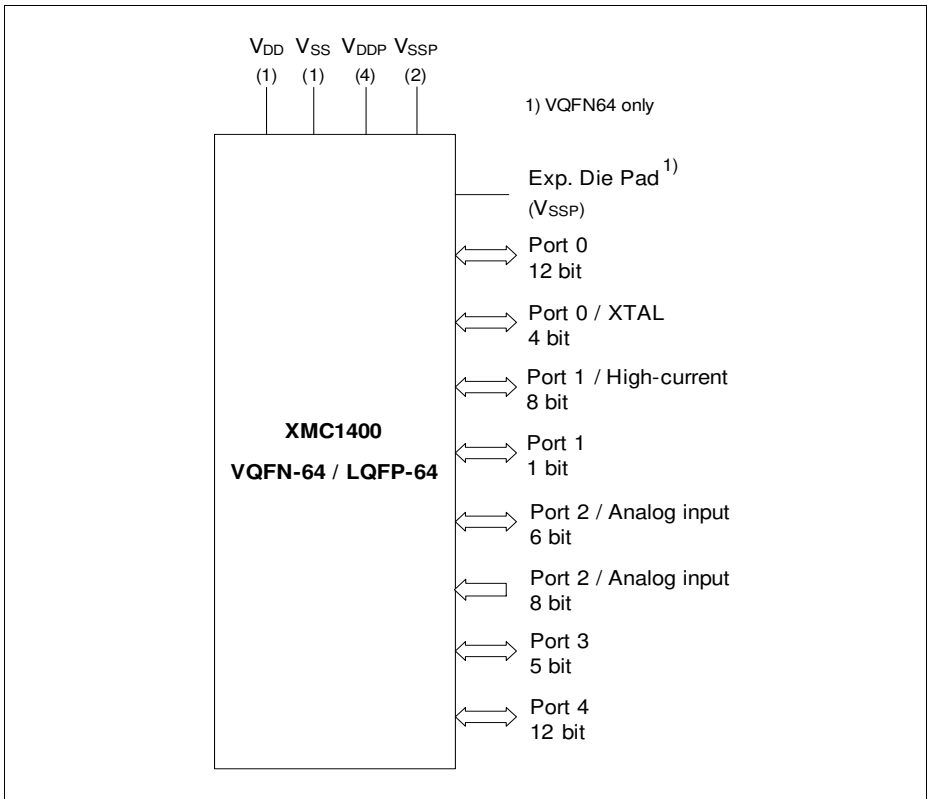

Figure 5 XMC1400 Logic Symbol for PG-LQFP-64-26 / PG-VQFN-64-6

2.2 Pin Configuration and Definition

The following figures summarize all pins, showing their locations on the different packages.

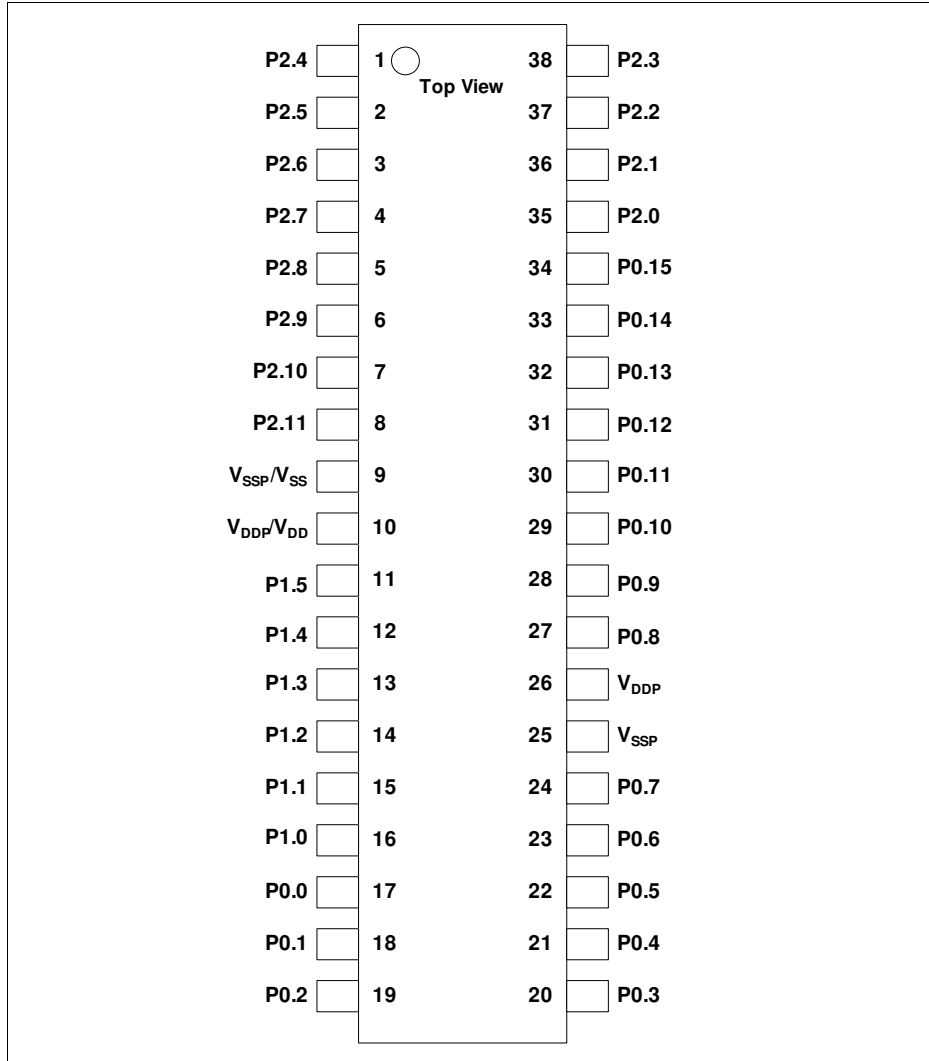

Figure 6 XMC1400 PG-TSSOP-38-9 Pin Configuration (top view)

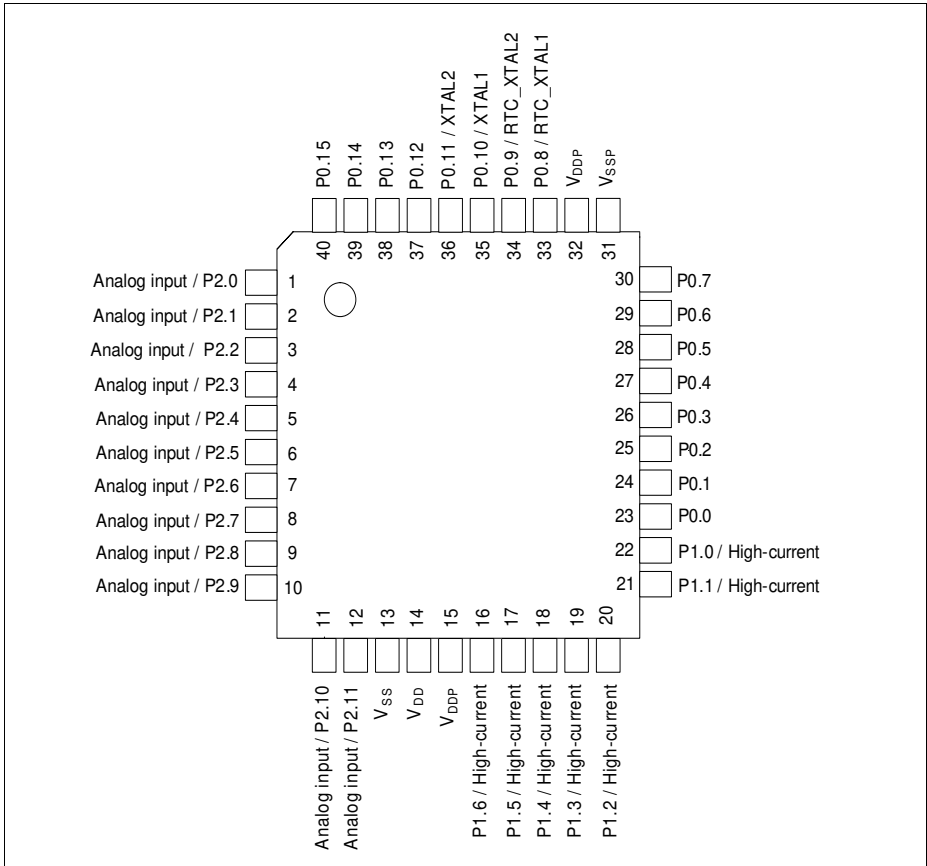

Figure 7 XMC1400 PG-VQFN-40-17 Pin Configuration (top view)

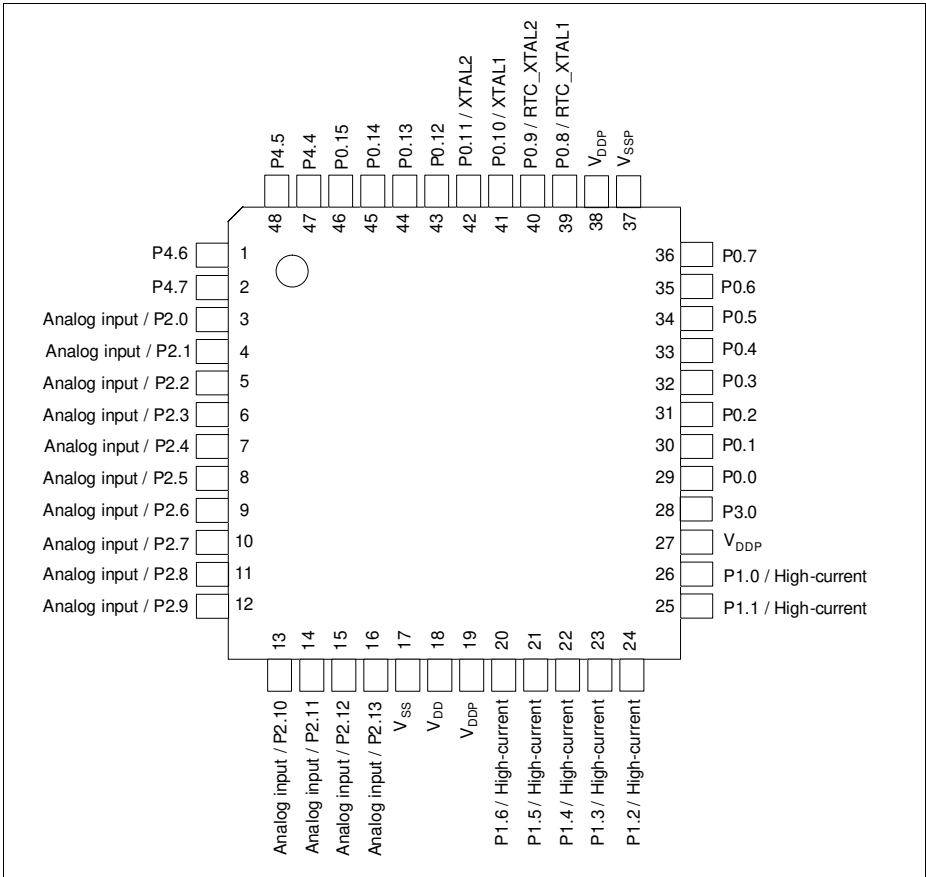

Figure 8 XMC1400 PG-VQFN-48-73 Pin Configuration (top view)

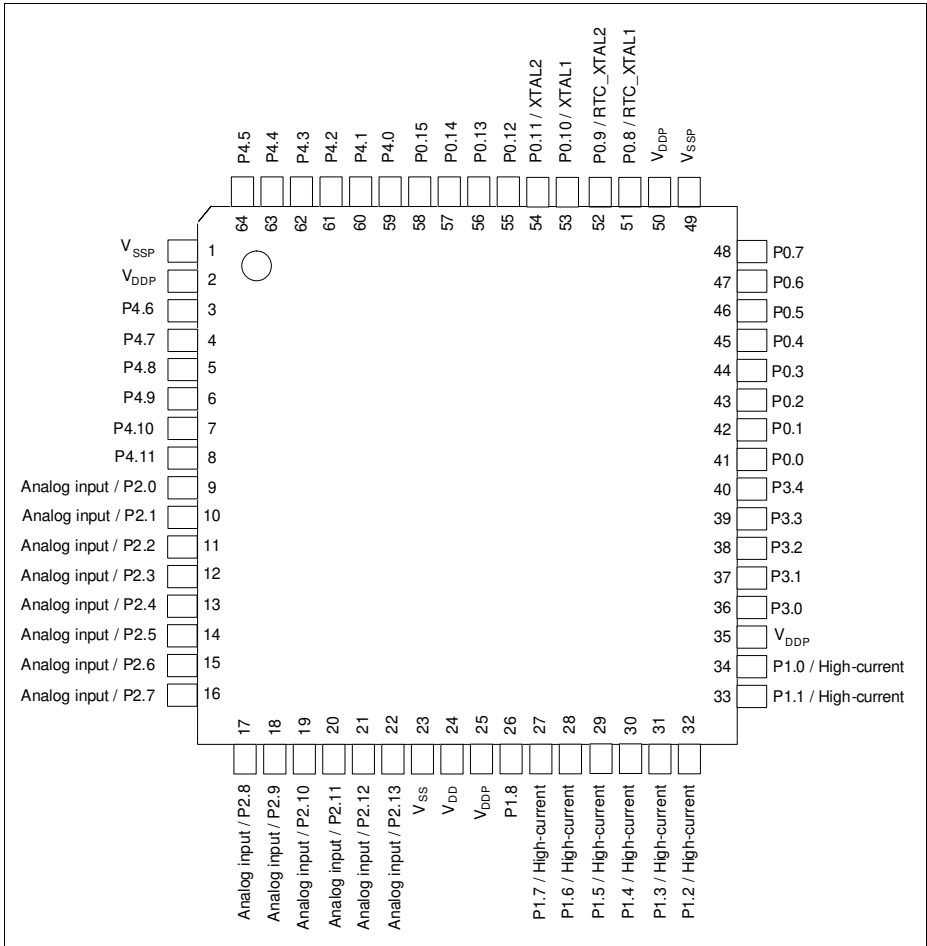

Figure 9 XMC1400 PG-LQFP-64-26 / PG-VQFN-64-6 Pin Configuration (top view)

2.2.1 Package Pin Summary

The following general building block is used to describe each pin:

Table 4 Package Pin Mapping Description

| Function | Package A | Package B | ... | Pad Type |
|----------|-----------|-----------|-----|-----------|
| Px.y | N | N | | Pad Class |

The table is sorted by the “Function” column, starting with the regular Port pins (Px.y), followed by the supply pins.

The following columns, titled with the supported package variants, lists the package pin number to which the respective function is mapped in that package.

The “Pad Type” indicates the employed pad type:

- STD_INOUT (standard bi-directional pads)
- STD_INOUT/AN (standard bi-directional pads with analog input)
- STD_INOUT/clock (standard bi-directional pads with oscillator function)
- High Current (high current bi-directional pads)
- STD_IN/AN (standard input pads with analog input)
- Power (power supply)

Details about the pad properties are defined in the Electrical Parameter chapter.

Table 5 Package Pin Mapping

| Function | LQFP 64, VQFN 64 | VQFN 48 | VQFN 40 | TSSOP 38 | Pad Type | Notes |
|------------------------|---------------------------|------------|------------|-------------|------------------------|-------|
| P0.0 | 41 | 29 | 23 | 17 | STD_INOUT | |
| P0.1 | 42 | 30 | 24 | 18 | STD_INOUT | |
| P0.2 | 43 | 31 | 25 | 19 | STD_INOUT | |
| P0.3 | 44 | 32 | 26 | 20 | STD_INOUT | |
| P0.4 | 45 | 33 | 27 | 21 | STD_INOUT | |
| P0.5 | 46 | 34 | 28 | 22 | STD_INOUT | |
| P0.6 | 47 | 35 | 29 | 23 | STD_INOUT | |
| P0.7 | 48 | 36 | 30 | 24 | STD_INOUT | |
| P0.8/ RTC_ XTAL1 | 51 | 39 | 33 | 27 | STD_INOUT /clock_IN | |

General Device Information
Table 5 Package Pin Mapping (cont'd)

| Function | LQFP 64, VQFN 64 | VQFN 48 | VQFN 40 | TSSOP 38 | Pad Type | Notes |
|------------------------|---------------------------|------------|------------|-------------|------------------------|-------|
| P0.9/ RTC_ XTAL2 | 52 | 40 | 34 | 28 | STD_INOUT /clock_O | |
| P0.10/ XTAL1 | 53 | 41 | 35 | 29 | STD_INOUT /clock_IN | |
| P0.11/ XTAL2 | 54 | 42 | 36 | 30 | STD_INOUT /clock_O | |
| P0.12 | 55 | 43 | 37 | 31 | STD_INOUT | |
| P0.13 | 56 | 44 | 38 | 32 | STD_INOUT | |
| P0.14 | 57 | 45 | 39 | 33 | STD_INOUT | |
| P0.15 | 58 | 46 | 40 | 34 | STD_INOUT | |
| P1.0 | 34 | 26 | 22 | 16 | High Current | |
| P1.1 | 33 | 25 | 21 | 15 | High Current | |
| P1.2 | 32 | 24 | 20 | 14 | High Current | |
| P1.3 | 31 | 23 | 19 | 13 | High Current | |
| P1.4 | 30 | 22 | 18 | 12 | High Current | |
| P1.5 | 29 | 21 | 17 | 11 | High Current | |
| P1.6 | 28 | 20 | 16 | - | High Current | |
| P1.7 | 27 | - | - | - | High Current | |
| P1.8 | 26 | - | - | - | STD_INOUT | |
| P2.0 | 9 | 3 | 1 | 35 | STD_INOUT /AN | |
| P2.1 | 10 | 4 | 2 | 36 | STD_INOUT /AN | |
| P2.2 | 11 | 5 | 3 | 37 | STD_IN/AN | |
| P2.3 | 12 | 6 | 4 | 38 | STD_IN/AN | |
| P2.4 | 13 | 7 | 5 | 1 | STD_IN/AN | |
| P2.5 | 14 | 8 | 6 | 2 | STD_IN/AN | |
| P2.6 | 15 | 9 | 7 | 3 | STD_IN/AN | |
| P2.7 | 16 | 10 | 8 | 4 | STD_IN/AN | |

General Device Information

Table 5 Package Pin Mapping (cont'd)

| Function | LQFP 64, VQFN 64 | VQFN 48 | VQFN 40 | TSSOP 38 | Pad Type | Notes |
|----------|---------------------------|------------|------------|-------------|------------------|----------------------------------|
| P2.8 | 17 | 11 | 9 | 5 | STD_IN/AN | |
| P2.9 | 18 | 12 | 10 | 6 | STD_IN/AN | |
| P2.10 | 19 | 13 | 11 | 7 | STD_INOUT /AN | |
| P2.11 | 20 | 14 | 12 | 8 | STD_INOUT /AN | |
| P2.12 | 21 | 15 | - | - | STD_INOUT /AN | |
| P2.13 | 22 | 16 | - | - | STD_INOUT /AN | |
| P3.0 | 36 | 28 | - | - | STD_INOUT | |
| P3.1 | 37 | - | - | - | STD_INOUT | |
| P3.2 | 38 | - | - | - | STD_INOUT | |
| P3.3 | 39 | - | - | - | STD_INOUT | |
| P3.4 | 40 | - | - | - | STD_INOUT | |
| P4.0 | 59 | - | - | - | STD_INOUT | |
| P4.1 | 60 | - | - | - | STD_INOUT | |
| P4.2 | 61 | - | - | - | STD_INOUT | |
| P4.3 | 62 | - | - | - | STD_INOUT | |
| P4.4 | 63 | 47 | - | - | STD_INOUT | |
| P4.5 | 64 | 48 | - | - | STD_INOUT | |
| P4.6 | 3 | 1 | - | - | STD_INOUT | |
| P4.7 | 4 | 2 | - | - | STD_INOUT | |
| P4.8 | 5 | - | - | - | STD_INOUT | |
| P4.9 | 6 | - | - | - | STD_INOUT | |
| P4.10 | 7 | - | - | - | STD_INOUT | |
| P4.11 | 8 | - | - | - | STD_INOUT | |
| VSS | 23 | 17 | 13 | 9 | Power | Supply GND, ADC reference GND |

General Device Information

Table 5 Package Pin Mapping (cont'd)

| Function | LQFP 64, VQFN 64 | VQFN 48 | VQFN 40 | TSSOP 38 | Pad Type | Notes |
|----------|-------------------------------------|------------|------------|-------------|----------|--|
| VDD | 24 | 18 | 14 | 10 | Power | Supply VDD, ADC reference voltage/ ORC reference voltage |
| VDDP | 25 | 19 | 15 | 10 | Power | When VDD is supplied, VDDP has to be supplied with the same voltage. |
| VDDP | 2 | - | - | - | Power | I/O port supply |
| VDDP | 35 | 27 | - | - | Power | I/O port supply |
| VDDP | 50 | 38 | 32 | 26 | Power | I/O port supply |
| VSSP | 1 | - | - | - | Power | I/O port ground |
| VSSP | 49 | 37 | 31 | 25 | Power | I/O port ground |
| VSSP | Exp. Pad (in VQFN 64 only) | Exp. Pad | Exp. Pad | - | Power | Exposed Die Pad The exposed die pad is connected internally to VSSP. For proper operation, it is mandatory to connect the exposed pad to the board ground. For thermal aspects, please refer to the Package and Reliability chapter. |

2.2.2 Port Pin for Boot Modes

Port functions can be overruled by the boot mode selected. The type of boot mode is selected via BMI. **Table 6** shows the port pins used for the various boot modes.

Table 6 Port Pin for Boot Modes

| Pin | Boot | Boot Description |
|-------|-----------|--|
| P0.13 | CS(O) | SSC BSL mode |
| P0.14 | SWDIO_0 | Debug mode (SWD) |
| | SPD_0 | Debug mode (SPD) |
| | RX/TX | ASC BSL half-duplex mode |
| | RX | ASC BSL full-duplex mode |
| | RX | CAN BSL mode |
| | SCLK(O) | SSC BSL mode |
| P0.15 | SWDCLK_0 | Debug mode (SWD) |
| | TX | ASC BSL full-duplex mode |
| | TX | CAN BSL mode |
| | DATA(I/O) | SSC BSL mode |
| P1.2 | SWDCLK_1 | Debug mode (SWD) |
| | TX | ASC BSL full-duplex mode |
| | TX | CAN BSL mode |
| P1.3 | SWDIO_1 | Debug mode (SWD) |
| | SPD_1 | Debug mode (SPD) |
| | RX/TX | ASC BSL half-duplex mode |
| | RX | ASC BSL full-duplex mode |
| | RX | CAN BSL mode |
| P4.6 | HWCON0 | Boot Pins |
| P4.7 | HWCON1 | (Boot from pins mode must be selected) |

2.2.3 Port I/O Function Description

The following general building block is used to describe the I/O functions of each PORT pin:

Table 7 Port I/O Function Description

| Function | Outputs | | Inputs | |
|----------|----------|----------|----------|----------|
| | ALT1 | ALTn | Input | Input |
| P0.0 | | MODA.OUT | MODC.INA | |
| Pn.y | MODA.OUT | | MODA.INA | MODC.INB |

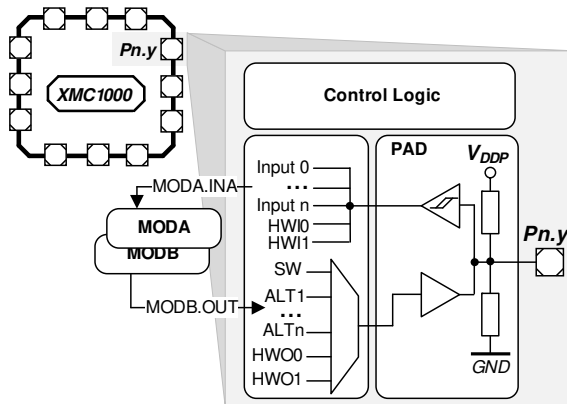

Figure 10 Simplified Port Structure

Pn.y is the port pin name, defining the control and data bits/registers associated with it. As GPIO, the port is under software control. Its input value is read via Pn_IN.y, Pn_OUT defines the output value.

Up to nine alternate output functions (ALT1 to ALT9) can be mapped to a single port pin, selected by Pn_IOC.R.PC. The output value is directly driven by the respective module, with the pin characteristics controlled by the port registers (within the limits of the connected pad).

The port pin input can be connected to multiple peripherals. Most peripherals have an input multiplexer to select between different possible input sources.

The input path is also active while the pin is configured as output. This allows to feedback an output to on-chip resources without wasting an additional external pin.

Please refer to the **Port I/O Functions** table for the complete Port I/O function mapping.

2.2.4 Hardware Controlled I/O Function Description

The following general building block is used to describe the hardware I/O and pull control functions of each PORT pin:

Table 8 Hardware Controlled I/O Function Description

| Function | Outputs | Inputs | Pull Control | |
|----------|----------|----------|--------------|----------|
| | HWO0 | HWI0 | HW0_PD | HW0_PU |
| P0.0 | MODB.OUT | MODB.INA | | |
| Pn.y | | | MODC.OUT | MODC.OUT |

By Pn_HWSEL, it is possible to select between different hardware “masters” (HWO0/HWI0, HWO1/HWI1). The selected peripheral can take control of the pin(s). Hardware control overrules settings in the respective port pin registers. Additional hardware signals HW0_PD/HW1_PD and HW0_PU/HW1_PU controlled by the peripherals can be used to control the pull devices of the pin.

Please refer to the **Hardware Controlled I/O Functions** table for the complete hardware I/O and pull control function mapping.

Port I/O Function Table

Table 9 Port I/O Functions

| Function | Outputs | | | | | | | | | Inputs | | | | | | | | | | | | |
|--------------------|-----------------|------------------|-----------------|---------------------------|-----------------|---------------------------|---------------------------|---------------------------|-------------------------|-----------------------|-----------------------|-----------------|-----------------|-----------------|-----------------|-----------------|------------------------|------------------------|------------------------|------------------------|-----------------|------------------------|
| | ALT1 | ALT2 | ALT3 | ALT4 | ALT5 | ALT6 | ALT7 | ALT8 | ALT9 | Input | Input | Input | Input | Input | Input | Input | Input | Input | Input | | | |
| P0.0 | ERU0.P DOUT0 | LEDTS0 .LINE7 | ERU0.G OUT0 | CCU40. OUT0 | CCU80. OUT00 | USIC0_ CH0.SE LO0 | USIC0_ CH1.SE LO0 | CCU81. OUT00 | USIC1_ CH1.DO UT0 | | BCCU0. TRAPIN B | CCU40.I NOAC | | | | | USIC1_ CH1.DX 0A | USIC0_ CH0.D X2A | | USIC0_ CH1.DX 2A | | |
| P0.1 | ERU0.P DOUT1 | LEDTS0 .LINE6 | ERU0.G OUT1 | CCU40. OUT1 | CCU80. OUT01 | BCCU0. OUT8 | SCU.VD ROP | USIC1_ CH1.SC LKOUT | USIC1_ CH1.DO UT0 | | | CCU40.I N1AC | | | | | USIC1_ CH1.DX 0B | USIC1_ CH1.D X1A | | | | |
| P0.2 | ERU0.P DOUT2 | LEDTS0 .LINE5 | ERU0.G OUT2 | CCU40. OUT2 | CCU80. OUT02 | VADC0. EMUX02 | CCU80. OUT10 | USIC1_ CH0.SC LKOUT | USIC1_ CH0.DO UT0 | | | CCU40.I N2AC | | | | | USIC1_ CH0.DX 0A | USIC1_ CH0.D X1A | | | | |
| P0.3 | ERU0.P DOUT3 | LEDTS0 .LINE4 | ERU0.G OUT3 | CCU40. OUT3 | CCU80. OUT03 | VADC0. EMUX01 | CCU80. OUT11 | USIC1_ CH1.SC LKOUT | USIC1_ CH0.DO UT0 | | | CCU40.I N3AC | | | | | USIC1_ CH0.DX 0B | | | | | |
| P0.4 | BCCU0. OUT0 | LEDTS0 .LINE3 | LEDTS0 .COL3 | CCU40. OUT1 | CCU80. OUT13 | VADC0. EMUX00 | WWDT. SERVIC E_OUT | USIC1_ CH1.SE LO0 | CAN.N0 _TXD | | | CCU41.I N0AB | CCU80.I N0AB | | | | | | | | | CAN.N0 _RXDA |
| P0.5 | BCCU0. OUT1 | LEDTS0 .LINE2 | LEDTS0 .COL2 | CCU40. OUT0 | CCU80. OUT12 | ACMP2. OUT | CCU80. OUT01 | VADC0. EMUX10 | CAN.N0 _TXD | | | CCU41.I N1AB | CCU80.I N1AB | | | | | | | | | CAN.N0 _RXDB |
| P0.6 | BCCU0. OUT2 | LEDTS0 .LINE1 | LEDTS0 .COL1 | CCU40. OUT0 | CCU80. OUT11 | USIC0_ CH1.MC LKOUT | USIC0_ CH1.DO UT0 | VADC0. EMUX11 | CCU41. OUT0 | | CCU40.I N0AB | CCU41.I N2AB | | | | | | | | | | USIC0_ CH1.DX 0C |
| P0.7 | BCCU0. OUT3 | LEDTS0 .LINE0 | LEDTS0 .COL0 | CCU40. OUT1 | CCU80. OUT10 | USIC0_ CH0.SC LKOUT | USIC0_ CH1.DO UT0 | VADC0. EMUX12 | CCU41. OUT1 | | CCU40.I N1AB | CCU41.I N3AB | | | | | USIC0_ CH0.D X1C | USIC0_ CH1.DX 0D | USIC0_ CH1.DX 1C | | | |
| P0.8/ RTC_XTAL1 | BCCU0. OUT4 | LEDTS1 .LINE0 | LEDTS0 .COLA | CCU40. OUT20 | CCU80. OUT20 | USIC0_ CH0.SC LKOUT | USIC0_ CH1.SC LKOUT | CCU81. OUT20 | CCU41. OUT2 | | CCU40.I N2AB | | | | | | USIC0_ CH0.D X1B | | USIC0_ CH1.DX 1B | | | |
| P0.9/ RTC_XTAL2 | BCCU0. OUT5 | LEDTS1 .LINE1 | LEDTS0 .COL6 | CCU40. OUT3 | CCU80. OUT21 | USIC0_ CH0.SE LO0 | USIC0_ CH1.SE LO0 | CCU81. OUT21 | CCU41. OUT3 | | CCU40.I N3AB | | | | | | USIC0_ CH0.D X2B | | USIC0_ CH1.DX 2B | | | |
| P0.10/ XTAL1 | BCCU0. OUT6 | LEDTS1 .LINE2 | LEDTS0 .COL5 | ACMP0. OUT | CCU80. OUT22 | USIC0_ CH0.SE LO1 | USIC0_ CH1.SE LO1 | CCU81. OUT22 | | | | CCU80.I N2AB | CCU81.I N2AB | | | | USIC0_ CH0.D X2C | | USIC0_ CH1.DX 2C | | | |
| P0.11/ XTAL2 | BCCU0. OUT7 | LEDTS1 .LINE3 | LEDTS0 .COL4 | USIC0_ CH0.MC LKOUT | CCU80. OUT23 | USIC0_ CH0.SE LO2 | USIC0_ CH1.SE LO2 | CCU81. OUT23 | | | | | | | | | USIC0_ CH0.D X2D | | USIC0_ CH1.DX 2D | | | |
| P0.12 | BCCU0. OUT6 | LEDTS1 .LINE4 | LEDTS0 .COL3 | LEDTS1 .COL3 | CCU80. OUT33 | USIC0_ CH0.SE LO3 | CCU80. OUT20 | | CAN.N1 _TXD | BCCU0. TRAPIN A | CCU40.I N0AA | CCU40.I N1AA | CCU40.I N2AA | CCU80.I N0AU | CCU40.I N3AA | CCU80.I N0AA | USIC0_ CH0.D X2E | CCU80.I N1AA | CCU80.I N2AA | CAN.N1 _RXDA | CCU80.I N3AA | |

Table 9 Port I/O Functions (cont'd)

| Function | Outputs | | | | | | | | Inputs | | | | | | | | | | | |
|----------|--------------------------|---------------------------|---------------------------|---------------------------|-----------------|---------------------------|---------------------------|-----------------|----------------|---------------|-----------------|-------|-----------------|-----------------|------------------------|------------------------|------------------------|------------------------|-----------------|-----------------|
| | ALT1 | ALT2 | ALT3 | ALT4 | ALT5 | ALT6 | ALT7 | ALT8 | ALT9 | Input | Input | Input | Input | Input | Input | Input | Input | Input | Input | |
| P0.13 | WWDT. SERVIC E_OUT | LEDTS1 LINE5 | LEDTS0 .COL2 | LEDTS1 .COL2 | CCU80. OUT32 | USIC0. CH0.SE LO4 | CCU80. OUT21 | | CAN.N1 _TXD | | | | CCU80.1 N3AB | CCU81.1 N1AU | POSIF0. IN0B | | USIC0_ CH0.D X2F | | | CAN.N1 _RXDB |
| P0.14 | BCCU0. OUT7 | LEDTS1 LINE6 | LEDTS0 .COL1 | LEDTS1 .COL1 | CCU80. OUT31 | USIC0_ CH0.DO UT0 | USIC0_ CH0.SC LKOUT | | CAN.N0 _TXD | | | | CCU81.1 N2AU | POSIF0. IN1B | USIC0_ CH0.DX 0A | USIC0_ CH0.D X1A | USIC1_ CH1.DX 5B | | CAN.N0 _RXDC | |
| P0.15 | BCCU0. OUT8 | LEDTS1 LINE7 | LEDTS0 .COL0 | LEDTS1 .COL0 | CCU80. OUT30 | USIC0_ CH0.DO UT0 | USIC0_ CH1.MC LKOUT | | CAN.N0 _TXD | | | | CCU81.1 N3AU | POSIF0. IN2B | USIC0_ CH0.DX 0B | | USIC1_ CH1.DX 3B | USIC1_ CH1.DX 4B | CAN.N0 _RXDD | |
| P1.0 | BCCU0. OUT0 | CCU40. OUT0 | LEDTS0 .COL0 | LEDTS1 .COLA | CCU80. OUT00 | ACMP1. OUT | USIC0_ CH0.DO UT0 | CCU81. OUT00 | CAN.N0 _TXD | | | | | POSIF0. IN2A | USIC0_ CH0.DX 0C | | | | CAN.N0 _RXDG | |
| P1.1 | ERU1.P DOUT1 | CCU40. OUT1 | LEDTS0 .COL1 | LEDTS1 .COL0 | CCU80. OUT01 | USIC0_ CH0.DO UT0 | USIC0_ CH1.SE LO0 | CCU81. OUT01 | CAN.N0 _TXD | | | | | POSIF0. IN1A | USIC0_ CH0.DX 0D | USIC0_ CH0.D X1D | | USIC0_ CH1.DX 2E | CAN.N0 _RXDH | |
| P1.2 | ERU1.P DOUT2 | CCU40. OUT2 | LEDTS0 .COL2 | LEDTS1 .COL1 | CCU80. OUT10 | ACMP2. OUT | USIC0_ CH1.DO UT0 | CCU81. OUT10 | CAN.N1 _TXD | | | | | POSIF0. IN0A | | | USIC0_ CH1.DX 0B | | CAN.N1 _RXDG | |
| P1.3 | ERU1.P DOUT3 | CCU40. OUT3 | LEDTS0 .COL3 | LEDTS1 .COL2 | CCU80. OUT11 | USIC0_ CH1.SC LKOUT | USIC0_ CH1.DO UT0 | CCU81. OUT11 | CAN.N1 _TXD | | | | | | | | USIC0_ CH1.DX 0A | USIC0_ CH1.DX 1A | CAN.N1 _RXDH | |
| P1.4 | ERU1.P DOUT0 | USIC0_ CH1.SC LKOUT | LEDTS0 .COL4 | LEDTS1 .COL3 | CCU80. OUT20 | USIC0_ CH0.SE LO0 | USIC0_ CH1.SE LO1 | CCU81. OUT20 | CCU41. OUT0 | | | | | | USIC0_ CH0.DX 5E | | USIC0_ CH1.DX 5E | | | |
| P1.5 | ERU1.P DOUT1 | USIC0_ CH0.DO UT0 | LEDTS0 COLA | BCCU0. OUT1 | CCU80. OUT21 | USIC0_ CH0.SE LO1 | USIC0_ CH1.SE LO2 | CCU81. OUT21 | CCU41. OUT1 | | | | | | | | USIC0_ CH1.DX 5F | | | |
| P1.6 | ERU1.P DOUT2 | USIC0_ CH1.DO UT0 | LEDTS0 COL5 | USIC0_ CH0.SC LKOUT | BCCU0. OUT2 | USIC0_ CH0.SE LO2 | USIC0_ CH1.SE LO3 | CCU81. OUT30 | CCU41. OUT2 | | | | | POSIF1. IN2A | USIC0_ CH0.DX 5F | | | | | |
| P1.7 | BCCU0. OUT8 | CCU40. OUT3 | LEDTS0 COL6 | LEDTS1 COL4 | | ACMP3. OUT | ERU1.P DOUT3 | CCU81. OUT31 | CCU41. OUT3 | | | | | POSIF1. IN1A | USIC1_ CH0.DX 5B | | | USIC1_ CH1.DX 2C | | |
| P1.8 | BCCU0. OUT0 | CCU40. OUT0 | USIC1_ CH1.SC LKOUT | VADC0. EMUX02 | | ACMP1. OUT | ERU1.P DOUT0 | CCU81. OUT32 | | | | | | POSIF1. IN0A | USIC1_ CH0.DX 3B | USIC1_ CH0.D X4B | | USIC1_ CH1.DX 1C | | |
| P2.0 | ERU0.P DOUT3 | CCU40. OUT0 | ERU0.G OUT3 | LEDTS1 COL5 | CCU80. OUT20 | USIC0_ CH0.DO UT0 | USIC0_ CH0.SC LKOUT | CCU81. OUT20 | CAN.N0 _TXD | | VADC0. G0CH5 | | | | USIC0_ CH0.DX 0E | USIC0_ CH0.D X1E | | USIC0_ CH1.DX 2F | CAN.N0 _RXDE | ERU0.0 B0 |
| P2.1 | ERU0.P DOUT2 | CCU40. OUT1 | ERU0.G OUT2 | LEDTS1 COL6 | CCU80. OUT21 | USIC0_ CH0.DO UT0 | USIC0_ CH1.SC LKOUT | CCU81. OUT21 | CAN.N0 _TXD | ACMP2.1 NP | VADC0. G0CH6 | | | | USIC0_ CH0.DX 0F | | USIC0_ CH1.DX 3A | USIC0_ CH1.DX 4A | CAN.N0 _RXDF | ERU0.1 B0 |

Table 9 Port I/O Functions (cont'd)

| Function | Outputs | | | | | | | | | Inputs | | | | | | | | | | | |
|----------|-----------------|-------------------------|---------------------------|---------------------------|-----------------|---------------------------|-------------------------|-----------------|----------------|-----------------------|-----------------|-----------------|-----------------|------------------------|------------------------|------------------------|------------------------|------------------------|------------------------|-----------------|--------------|
| | ALT1 | ALT2 | ALT3 | ALT4 | ALT5 | ALT6 | ALT7 | ALT8 | ALT9 | Input | Input | Input | Input | Input | Input | Input | Input | Input | Input | | |
| P2.2 | | | | | | | | | | ACMP2.1 NN | VADC0. G0CH7 | | ORC0.A N | USIC1_ CH0.DX 5E | | USIC0_ CH0.DX 3A | USIC0_ CH0.D X4A | USIC0_ CH1.DX 5A | | ERU0.0 B1 | |
| P2.3 | | | | | | | | | | | VADC0. G1CH5 | | ORC1.A N | USIC1_ CH0.DX 3E | USIC1_ CH0.DX 4E | USIC0_ CH1.DX 3C | USIC0_ CH0.D X5B | USIC0_ CH1.DX 3C | USIC0_ CH1.DX 4C | ERU0.1 B1 | |
| P2.4 | | | | | | | | | | | VADC0. G1CH6 | | ORC2.A N | USIC1_ CH1.DX 3C | USIC1_ CH1.DX 4C | USIC0_ CH0.DX 3B | USIC0_ CH0.D X4B | USIC1_ CH0.DX 5F | USIC0_ CH1.DX 5B | ERU0.0 A1 | |
| P2.5 | | | | | | | | | | | VADC0. G1CH7 | | ORC3.A N | USIC1_ CH1.DX 5D | | USIC0_ CH0.DX 5D | | USIC0_ CH1.DX 3E | USIC0_ CH1.DX 4E | ERU0.1 A1 | |
| P2.6 | | | | | | | | | | ACMP1.1 NN | VADC0. G0CH0 | | ORC4.A N | USIC1_ CH1.DX 3E | USIC1_ CH1.DX 4E | USIC0_ CH0.DX 3E | USIC0_ CH0.D X4E | USIC0_ CH1.DX 5D | | ERU0.2 A1 | |
| P2.7 | | | | | | | | | | ACMP1.1 NP | VADC0. G1CH1 | | ORC5.A N | USIC1_ CH1.DX 5E | | USIC0_ CH0.DX 5C | | USIC0_ CH1.DX 3D | USIC0_ CH1.DX 4D | ERU0.3 A1 | |
| P2.8 | | | | | | | | | | ACMP0.1 NN | VADC0. G0CH1 | VADC0. G1CH0 | ORC6.A N | | | USIC0_ CH0.DX 3D | USIC0_ CH0.D X4D | USIC0_ CH1.DX 5C | | ERU0.3 B1 | |
| P2.9 | | | | | | | | | | ACMP0.1 NP | VADC0. G0CH2 | VADC0. G1CH4 | ORC7.A N | | | USIC0_ CH0.DX 5A | | USIC0_ CH1.DX 3B | USIC0_ CH1.DX 4B | ERU0.3 B0 | |
| P2.10 | ERU0.P DOUT1 | CCU40. OUT2 | ERU0.G OUT1 | LEDTS1 .COL4 | CCU80. OUT30 | ACMP0. OUT | USIC0_ CH1.DO UT0 | | CAN.N1 _TXD | | VADC0. G0CH3 | VADC0. G1CH2 | | | | USIC0_ CH0.DX 3C | USIC0_ CH0.D X4C | USIC0_ CH1.DX 0F | | CAN.N1 _RXDE | ERU0.2 B0 |
| P2.11 | ERU0.P DOUT0 | CCU40. OUT3 | ERU0.G OUT0 | LEDTS1 .COL3 | CCU80. OUT31 | USIC0_ CH1.SC LKOUT | USIC0_ CH1.DO UT0 | | CAN.N1 _TXD | ACMP.R EF | VADC0. G0CH4 | VADC0. G1CH3 | | | | | | USIC0_ CH1.DX 0E | USIC0_ CH1.DX 1E | CAN.N1 _RXDF | ERU0.2 B1 |
| P2.12 | BCCU0. OUT3 | VADC0. EMUX00 | USIC1_ CH0.SC LKOUT | USIC1_ CH1.SC LKOUT | | ACMP2. OUT | USIC1_ CH1.DO UT0 | LEDTS2 .COL6 | | ACMP3.1 NN | | | | | USIC1_ CH0.DX 3A | USIC1_ CH0.D X4A | USIC1_ CH1.DX 0C | USIC1_ CH1.DX 1B | | ERU1.3 A2 | |
| P2.13 | BCCU0. OUT4 | CCU40. OUT3 | USIC1_ CH0.MC LKOUT | CCU81. OUT31 | | VADC0. EMUX01 | USIC1_ CH1.DO UT0 | CCU81. OUT33 | CCU41. OUT3 | ACMP3.1 NP | | | | | USIC1_ CH0.DX 5A | | USIC1_ CH1.DX 0D | | | ERU1.3 A3 | |
| P3.0 | BCCU0. OUT0 | USIC1_ CH1.DO UT0 | USIC1_ CH1.SC LKOUT | LEDTS2 .COLA | CCU80. OUT21 | ACMP1. OUT | USIC1_ CH0.SE LO1 | CCU81. OUT21 | CCU41. OUT0 | BCCU0. TRAPIN C | CCU41.1 N0AA | CCU41.1 N1AA | CCU41.1 N2AA | CCU41.1 N3AA | CCU81.1 N0AA | CCU81.1 N1AA | CCU81. IN2AA | USIC1_ CH1.DX 0E | USIC1_ CH1.DX 1D | CCU81.1 N3AA | ERU1.0 A1 |
| P3.1 | BCCU0. OUT1 | USIC1_ CH1.DO UT0 | | LEDTS2 .COL0 | CCU80. OUT20 | ACMP3. OUT | USIC1_ CH0.SE LO0 | CCU81. OUT20 | CCU41. OUT1 | | | | | | | USIC1_ CH0.D X2F | | USIC1_ CH1.DX 0F | | | ERU1.1 A1 |

Table 9 Port I/O Functions (cont'd)

| Function | Outputs | | | | | | | | | Inputs | | | | | | | | | | | | |
|----------|----------------|---------------------------|---------------------------|-----------------|-----------------|---------------------------|---------------------------|-----------------|----------------|--------|-----------------|-----------------|-----------------|-----------------|-----------------|------------------------|------------------------|------------------------|------------------------|-------|-----------------|--------------|
| | ALT1 | ALT2 | ALT3 | ALT4 | ALT5 | ALT6 | ALT7 | ALT8 | ALT9 | Input | Input | Input | Input | Input | Input | Input | Input | Input | Input | Input | Input | Input |
| P3.2 | BCCU0. OUT2 | USIC1_ CH1.SC LKOUT | | LEDTS2 .COL1 | CCU80. OUT11 | ACMP2. OUT | USIC1_ CH0.SC LKOUT | CCU81. OUT11 | CCU41. OUT2 | | | | | | | USIC1_ CH0.DX 3C | USIC1_ CH0.D X4C | USIC1_ CH1.DX 3D | USIC1_ CH1.DX 4D | | | ERU1.2 A1 |
| P3.3 | BCCU0. OUT5 | USIC1_ CH0.DO UT0 | | LEDTS2 .COL2 | CCU80. OUT10 | ACMP0. OUT | USIC1_ CH1.SE LO0 | CCU81. OUT10 | CCU41. OUT3 | | | | | | | USIC1_ CH0.DX 0E | | | USIC1_ CH1.DX 2A | | | ERU1.1 A3 |
| P3.4 | BCCU0. OUT6 | USIC1_ CH0.DO UT0 | USIC1_ CH0.SC LKOUT | LEDTS2 .COL3 | CCU80. OUT01 | USIC1_ CH1.MC LKOUT | USIC1_ CH1.SE LO1 | CCU81. OUT01 | | | | | | | | USIC1_ CH0.DX 0F | USIC1_ CH0.D X1E | | USIC1_ CH1.DX 2B | | | ERU1.2 A3 |
| P4.0 | BCCU0. OUT0 | ERU1.P DOUT0 | LEDTS2 .COL5 | ERU1.G OUT0 | CCU40. OUT0 | ACMP1. OUT | USIC1_ CH1.SE LO1 | CCU81. OUT10 | CCU41. OUT0 | | CCU40.I N0BA | CCU41.I N0AC | CCU80.I N0AU | | | | USIC1_ CH0.DX 3D | USIC1_ CH0.D X4D | | | | |
| P4.1 | BCCU0. OUT8 | ERU1.P DOUT1 | LEDTS2 .COL4 | ERU1.G OUT1 | CCU40. OUT1 | ACMP3. OUT | USIC1_ CH1.SE LO2 | CCU81. OUT11 | CCU41. OUT1 | | CCU40.I N1BA | CCU41.I N1AC | CCU80.I N1AU | | POSIF1. IN0B | | USIC1_ CH0.DX 5C | | | | | |
| P4.2 | BCCU0. OUT4 | ERU1.P DOUT2 | CCU81. OUT20 | ERU1.G OUT2 | CCU40. OUT2 | ACMP2. OUT | USIC1_ CH1.SE LO3 | CCU81. OUT12 | CCU41. OUT2 | | CCU40.I N2BA | CCU41.I N2AC | CCU80.I N2AU | CCU81.I N1AB | POSIF1. IN1B | | USIC1_ CH0.DX 5D | | | | | |
| P4.3 | BCCU0. OUT5 | ERU1.P DOUT3 | CCU81. OUT21 | ERU1.G OUT3 | CCU40. OUT3 | ACMP0. OUT | USIC1_ CH0.SC LKOUT | CCU81. OUT13 | CCU41. OUT3 | | CCU40.I N3BA | CCU41.I N3AC | CCU80.I N3AU | | POSIF1. IN2B | | USIC1_ CH0.D X1B | | | | | |
| P4.4 | BCCU0. OUT0 | LEDTS2 .LINE0 | | LEDTS1 .COLA | CCU80. OUT00 | USIC1_ CH0.DO UT0 | | CCU81. OUT00 | CCU41. OUT0 | | | | CCU41.I N0AV | | | | USIC1_ CH0.DX 0C | | USIC1_ CH1.DX 5F | | | ERU1.0 A2 |
| P4.5 | BCCU0. OUT8 | LEDTS2 .LINE1 | | LEDTS1 .COL6 | CCU80. OUT01 | USIC1_ CH0.DO UT0 | USIC1_ CH0.SC LKOUT | CCU81. OUT01 | CCU41. OUT1 | | | | CCU41.I N1AV | | | | USIC1_ CH0.DX 0D | USIC1_ CH0.D X1C | | | | ERU1.1 A2 |
| P4.6 | BCCU0. OUT2 | LEDTS2 .LINE2 | CCU81. OUT10 | LEDTS1 .COL5 | CCU80. OUT10 | | USIC1_ CH0.SC LKOUT | CCU81. OUT02 | CCU41. OUT2 | | | | CCU41.I N2AV | | CCU81.I N0AB | | | USIC1_ CH0.D X1D | | | | ERU1.2 A2 |
| P4.7 | BCCU0. OUT5 | LEDTS2 .LINE3 | CCU81. OUT11 | LEDTS1 .COL4 | CCU80. OUT11 | | USIC1_ CH0.SE LO0 | CCU81. OUT03 | CCU41. OUT3 | | | | CCU41.I N3AV | | | | | USIC1_ CH0.D X2A | | | | ERU1.0 A3 |
| P4.8 | BCCU0. OUT7 | LEDTS2 .LINE4 | LEDTS2 .COL3 | LEDTS1 .COL3 | CCU80. OUT30 | CCU40. OUT0 | USIC1_ CH0.SE LO1 | CCU81. OUT30 | CAN.N1 _TXD | | CCU40.I N0AV | CCU41.I N0BA | | | | | | USIC1_ CH0.D X2B | | | CAN.N1 _RXDC | |
| P4.9 | BCCU0. OUT3 | LEDTS2 .LINE5 | LEDTS2 .COL2 | LEDTS1 .COL2 | CCU80. OUT31 | CCU40. OUT1 | USIC1_ CH0.SE LO2 | CCU81. OUT31 | CAN.N1 _TXD | | CCU40.I N1AV | CCU41.I N1BA | | | | | | USIC1_ CH0.D X2C | | | CAN.N1 _RXDD | |

Table 9 Port I/O Functions (cont'd)

| Function | Outputs | | | | | | | | | Inputs | | | | | | | | | | | | |
|----------|---------|-----------------|-----------------|-----------------|-----------------|----------------|-------------------------|-----------------|-----------------|-----------------------|-----------------|-----------------|-------|-----------------|-------|-------|-------|------------------------|------------------------|------------------------|-------|--|
| | ALT1 | ALT2 | ALT3 | ALT4 | ALT5 | ALT6 | ALT7 | ALT8 | ALT9 | Input | Input | Input | Input | Input | Input | Input | Input | Input | Input | Input | Input | |
| P4.10 | | LEDTS2 LINE6 | LEDTS2 .COL1 | LEDTS1 .COL1 | CCU80. OUT00 | CCU40. OUT2 | USIC1_ CH0.SE LO3 | CCU81. OUT32 | CCU81. OUT00 | BCCU0. TRAPIN D | CCU40.1 N2AV | CCU41.1 N2BA | | CCU81.1 N3AB | | | | USIC1_ CH0.D X2D | USIC1_ CH1.DX 5A | | | |
| P4.11 | | LEDTS2 LINE7 | LEDTS2 .COL0 | LEDTS1 .COL0 | CCU80. OUT01 | CCU40. OUT3 | USIC1_ CH0.SE LO4 | CCU81. OUT33 | CCU81. OUT01 | | CCU40.1 N3AV | CCU41.1 N3BA | | | | | | USIC1_ CH0.D X2E | USIC1_ CH1.DX 3A | USIC1_ CH1.DX 4A | | |

Table 10 Hardware I/O Controlled Functions

| Function | Outputs | Outputs | Inputs | Inputs | Pull Control | Pull Control | Pull Control | Pull Control |
|----------|------------------|-----------------|--------------|-----------------|--|---|---|--------------|
| | HWO0 | HWO1 | HWI0 | HWI1 | HW0_PD | HW0_PU | HW1_PD | HW1_PU |
| P0.0 | LEDTS0.EXTENDED7 | | LEDTS0.TSIN7 | LEDTS0.TSIN7 | Reserved for LEDTS Scheme A: pull-down disabled always | Reserved for LEDTS Scheme A: pull-down enabled always | Reserved for LEDTS Scheme B: pull-up enabled and pull-down disabled, and vice versa | |
| P0.1 | LEDTS0.EXTENDED6 | | LEDTS0.TSIN6 | LEDTS0.TSIN6 | | | | |
| P0.2 | LEDTS0.EXTENDED5 | | LEDTS0.TSIN5 | LEDTS0.TSIN5 | | | | |
| P0.3 | LEDTS0.EXTENDED4 | | LEDTS0.TSIN4 | LEDTS0.TSIN4 | | | | |
| P0.4 | LEDTS0.EXTENDED3 | | LEDTS0.TSIN3 | LEDTS0.TSIN3 | | | | |
| P0.5 | LEDTS0.EXTENDED2 | | LEDTS0.TSIN2 | LEDTS0.TSIN2 | | | | |
| P0.6 | LEDTS0.EXTENDED1 | | LEDTS0.TSIN1 | LEDTS0.TSIN1 | | | | |
| P0.7 | LEDTS0.EXTENDED0 | | LEDTS0.TSIN0 | LEDTS0.TSIN0 | | | | |
| P0.8 | LEDTS1.EXTENDED0 | | LEDTS1.TSIN0 | LEDTS1.TSIN0 | | | | |
| P0.9 | LEDTS1.EXTENDED1 | | LEDTS1.TSIN1 | LEDTS1.TSIN1 | | | | |
| P0.10 | LEDTS1.EXTENDED2 | | LEDTS1.TSIN2 | LEDTS1.TSIN2 | | | | |
| P0.11 | LEDTS1.EXTENDED3 | | LEDTS1.TSIN3 | LEDTS1.TSIN3 | | | | |
| P0.12 | LEDTS1.EXTENDED4 | | LEDTS1.TSIN4 | LEDTS1.TSIN4 | | | | |
| P0.13 | LEDTS1.EXTENDED5 | | LEDTS1.TSIN5 | LEDTS1.TSIN5 | | | | |
| P0.14 | LEDTS1.EXTENDED6 | | LEDTS1.TSIN6 | LEDTS1.TSIN6 | | | | |
| P0.15 | LEDTS1.EXTENDED7 | | LEDTS1.TSIN7 | LEDTS1.TSIN7 | | | | |
| P1.0 | | USIC0_CH0.DOUT0 | | USIC0_CH0.HWIN0 | BCCU0.OUT2 | BCCU0.OUT2 | | |
| P1.1 | | USIC0_CH0.DOUT1 | | USIC0_CH0.HWIN1 | BCCU0.OUT3 | BCCU0.OUT3 | | |
| P1.2 | | USIC0_CH0.DOUT2 | | USIC0_CH0.HWIN2 | BCCU0.OUT4 | BCCU0.OUT4 | | |

Table 10 Hardware I/O Controlled Functions (cont'd)

| Function | Outputs | Outputs | Inputs | Inputs | Pull Control | Pull Control | Pull Control | Pull Control |
|----------|---------|-----------------|--------|-----------------|--------------|--------------|--------------|--------------|
| | HWO0 | HWO1 | HWI0 | HWI1 | HW0_PD | HW0_PU | HW1_PD | HW1_PU |
| P1.3 | | USIC0_CH0.DOUT3 | | USIC0_CH0.HWIN3 | BCCU0.OUT5 | BCCU0.OUT5 | | |
| P1.4 | | | | | BCCU0.OUT6 | BCCU0.OUT6 | | |
| P1.5 | | | | | BCCU0.OUT7 | BCCU0.OUT7 | | |
| P1.6 | | | | | BCCU0.OUT8 | BCCU0.OUT8 | | |
| P1.7 | | | | | | | | |
| P1.8 | | | | | | | | |
| P2.0 | | | | | BCCU0.OUT1 | BCCU0.OUT1 | | |
| P2.1 | | | | | BCCU0.OUT6 | BCCU0.OUT6 | | |
| P2.2 | | | | | BCCU0.OUT0 | BCCU0.OUT0 | CCU40.OUT3 | CCU40.OUT3 |
| P2.3 | | | | | ACMP2.OUT | ACMP2.OUT | | |
| P2.4 | | | | | BCCU0.OUT8 | BCCU0.OUT8 | | |
| P2.5 | | | | | ACMP1.OUT | ACMP1.OUT | | |
| P2.6 | | | | | BCCU0.OUT2 | BCCU0.OUT2 | CCU40.OUT3 | CCU40.OUT3 |
| P2.7 | | | | | BCCU0.OUT8 | BCCU0.OUT8 | CCU40.OUT3 | CCU40.OUT3 |
| P2.8 | | | | | BCCU0.OUT1 | BCCU0.OUT1 | CCU40.OUT2 | CCU40.OUT2 |
| P2.9 | | | | | BCCU0.OUT7 | BCCU0.OUT7 | CCU40.OUT2 | CCU40.OUT2 |
| P2.10 | | | | | BCCU0.OUT4 | BCCU0.OUT4 | | |
| P2.11 | | | | | BCCU0.OUT5 | BCCU0.OUT5 | | |
| P2.12 | | | | | BCCU0.OUT3 | BCCU0.OUT3 | CCU41.OUT0 | CCU41.OUT0 |
| P2.13 | | | | | BCCU0.OUT4 | BCCU0.OUT4 | CCU41.OUT2 | CCU41.OUT2 |
| P3.0 | | | | | | | | |
| P3.1 | | USIC1_CH0.DOUT3 | | USIC1_CH0.HWIN3 | | | | |
| P3.2 | | USIC1_CH0.DOUT2 | | USIC1_CH0.HWIN2 | | | | |
| P3.3 | | USIC1_CH0.DOUT1 | | USIC1_CH0.HWIN1 | | | | |
| P3.4 | | USIC1_CH0.DOUT0 | | USIC1_CH0.HWIN0 | | | | |
| P4.0 | | | | | | | | |
| P4.1 | | | | | | | | |
| P4.2 | | | | | | | | |
| P4.3 | | | | | | | | |

Table 10 Hardware I/O Controlled Functions (cont'd)

| Function | Outputs | Outputs | Inputs | Inputs | Pull Control | Pull Control | Pull Control | Pull Control |
|----------|------------------|---------|--------------|--------------|--|---|---|--------------|
| | HWO0 | HWO1 | HWI0 | HWI1 | HW0_PD | HW0_PU | HW1_PD | HW1_PU |
| P4.4 | LEDTS2.EXTENDED0 | | LEDTS2.TSIN0 | LEDTS2.TSIN0 | Reserved for LEDTS Scheme A: pull-down disabled always | Reserved for LEDTS Scheme A: pull-down enabled always | Reserved for LEDTS Scheme B: pull-up enabled and pull-down disabled, and vice versa | |
| P4.5 | LEDTS2.EXTENDED1 | | LEDTS2.TSIN1 | LEDTS2.TSIN1 | | | | |
| P4.6 | LEDTS2.EXTENDED2 | | LEDTS2.TSIN2 | LEDTS2.TSIN2 | | | | |
| P4.7 | LEDTS2.EXTENDED3 | | LEDTS2.TSIN3 | LEDTS2.TSIN3 | | | | |
| P4.8 | LEDTS2.EXTENDED4 | | LEDTS2.TSIN4 | LEDTS2.TSIN4 | | | | |
| P4.9 | LEDTS2.EXTENDED5 | | LEDTS2.TSIN5 | LEDTS2.TSIN5 | | | | |
| P4.10 | LEDTS2.EXTENDED6 | | LEDTS2.TSIN6 | LEDTS2.TSIN6 | | | | |
| P4.11 | LEDTS2.EXTENDED7 | | LEDTS2.TSIN7 | LEDTS2.TSIN7 | | | | |

3 Electrical Parameter

This section provides the electrical parameter which are implementation-specific for the XMC1400.

3.1 General Parameters

3.1.1 Parameter Interpretation

The parameters listed in this section represent partly the characteristics of the XMC1400 and partly its requirements on the system. To aid interpreting the parameters easily when evaluating them for a design, they are indicated by the abbreviations in the "Symbol" column:

- **CC**
Such parameters indicate **C**ontroller **C**haracteristics, which are distinctive feature of the XMC1400 and must be regarded for a system design.
- **SR**
Such parameters indicate **S**ystem **R**equirements, which must be provided by the application system in which the XMC1400 is designed in.

3.1.2 Absolute Maximum Ratings

Stresses above the values listed under “Absolute Maximum Ratings” may cause permanent damage to the device. This is a stress rating only and functional operation of the device at these or any other conditions above those indicated in the operational sections of this specification is not implied. Exposure to absolute maximum rating conditions may affect device reliability.

Table 11 Absolute Maximum Rating Parameters

| Parameter | Symbol | | Values | | | Unit | Note / Test Condition |
|--|-------------------------|----|--------|------|------------------------------|------|-----------------------|
| | | | Min | Typ. | Max. | | |
| Junction temperature | T_J | SR | -40 | – | 115 | °C | – |
| Storage temperature | T_{ST} | SR | -40 | – | 125 | °C | – |
| Voltage on power supply pin with respect to V_{SSP} | V_{DDP} | SR | -0.3 | – | 6 | V | – |
| Voltage on digital pins with respect to V_{SSP} ¹⁾ | V_{IN} | SR | -0.5 | – | $V_{DDP} + 0.5$ or max. 6 | V | whichever is lower |
| Voltage on P2 pins with respect to V_{SSP} ²⁾ | V_{INP2} | SR | -0.3 | – | $V_{DDP} + 0.3$ | V | – |
| Voltage on analog input pins with respect to V_{SSP} | V_{AIN} V_{AREF} | SR | -0.5 | – | $V_{DDP} + 0.5$ or max. 6 | V | whichever is lower |
| Input current on any pin during overload condition | I_{IN} | SR | -10 | – | 10 | mA | – |
| Absolute maximum sum of all input currents during overload condition | ΣI_{IN} | SR | -50 | – | +50 | mA | – |

1) Excluding port pins P2.[1,2,6,7,8,9,11].

2) Applicable to port pins P2.[1,2,6,7,8,9,11].

3.1.3 Pin Reliability in Overload

When receiving signals from higher voltage devices, low-voltage devices experience overload currents and voltages that go beyond their own IO power supplies specification.

Table 12 defines overload conditions that will not cause any negative reliability impact if all the following conditions are met:

- full operation life-time is not exceeded
- **Operating Conditions** are met for
 - pad supply levels (V_{DDP})
 - temperature

If a pin current is outside of the **Operating Conditions** but within the overload conditions, then the parameters of this pin as stated in the Operating Conditions can no longer be guaranteed. Operation is still possible in most cases but with relaxed parameters.

Note: An overload condition on one or more pins does not require a reset.

Note: A series resistor at the pin to limit the current to the maximum permitted overload current is sufficient to handle failure situations like short to battery.

Table 12 Overload Parameters

| Parameter | Symbol | Values | | | Unit | Note / Test Condition |
|--|--------------|--------|------|------|------|-----------------------|
| | | Min. | Typ. | Max. | | |
| Input current on any port pin during overload condition | I_{OV} SR | -5 | – | 5 | mA | |
| Absolute sum of all input circuit currents during overload condition | I_{OVS} SR | – | – | 25 | mA | |

Figure 11 shows the path of the input currents during overload via the ESD protection structures. The diodes against V_{DDP} and ground are a simplified representation of these ESD protection structures.

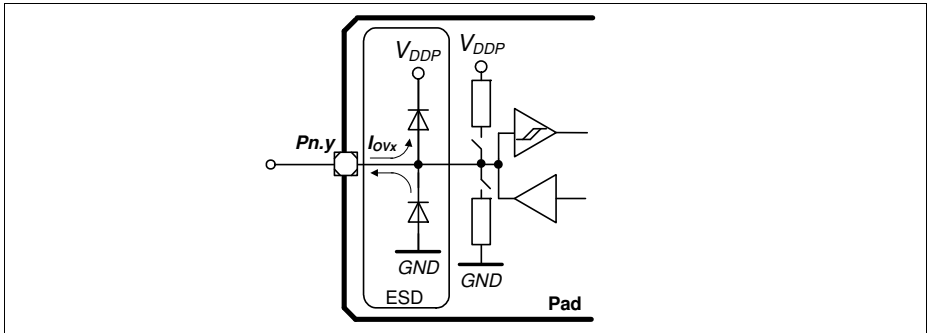

Figure 11 Input Overload Current via ESD structures

Table 13 and Table 14 list input voltages that can be reached under overload conditions. Note that the absolute maximum input voltages as defined in the **Absolute Maximum Ratings** must not be exceeded during overload.

Table 13 PN-Junction Characteristics for positive Overload

| Pad Type | $I_{OV} = 5 \text{ mA}$ |
|-----------------------------------|---|
| Standard, High-current, AN/DIG_IN | $V_{IN} = V_{DDP} + 0.5 \text{ V}$ $V_{AIN} = V_{DDP} + 0.5 \text{ V}$ $V_{AREF} = V_{DDP} + 0.5 \text{ V}$ |
| P2.[1,2,6:9,11] | $V_{INP2} = V_{DDP} + 0.3 \text{ V}$ |

Table 14 PN-Junction Characteristics for negative Overload

| Pad Type | $I_{OV} = 5 \text{ mA}$ |
|-----------------------------------|--|
| Standard, High-current, AN/DIG_IN | $V_{IN} = V_{SS} - 0.5 \text{ V}$ $V_{AIN} = V_{SS} - 0.5 \text{ V}$ $V_{AREF} = V_{SS} - 0.5 \text{ V}$ |
| P2.[1,2,6:9,11] | $V_{INP2} = V_{SS} - 0.3 \text{ V}$ |

3.1.4 Operating Conditions

The following operating conditions must not be exceeded in order to ensure correct operation and reliability of the XMC1400. All parameters specified in the following tables refer to these operating conditions, unless noted otherwise.

Table 15 Operating Conditions Parameters

| Parameter | Symbol | | Values | | | Unit | Note / Test Condition |
|--|--------------------|----|--------|------|------|------|-----------------------|
| | | | Min. | Typ. | Max. | | |
| Ambient Temperature | T_A | SR | -40 | – | 85 | °C | Temp. Range F |
| | | | -40 | – | 105 | °C | Temp. Range X |
| Digital supply voltage ¹⁾ | V_{DDP} | SR | 1.8 | – | 5.5 | V | |
| Short circuit current of digital outputs | I_{SC} | SR | -5 | – | 5 | mA | |
| Absolute sum of short circuit currents of the device | ΣI_{SC_D} | SR | – | – | 25 | mA | |

1) See also the Supply Monitoring thresholds, [Chapter 3.3.2](#).

3.2 DC Parameters

3.2.1 Input/Output Characteristics

Table 16 provides the characteristics of the input/output pins of the XMC1400.

Note: These parameters are not subject to production test, but verified by design and/or characterization.

Note: Unless otherwise stated, input DC and AC characteristics, including peripheral timings, assume that the input pads operate with the standard hysteresis.

Table 16 Input/Output Characteristics (Operating Conditions apply)

| Parameter | Symbol | | Limit Values | | Unit | Test Conditions |
|--|------------|----|----------------------|-----------------------|------|--|
| | | | Min. | Max. | | |
| Output low voltage on port pins (with standard pads) | V_{OLP} | CC | – | 1.0 | V | $I_{OL} = 11 \text{ mA}$ (5 V) $I_{OL} = 7 \text{ mA}$ (3.3 V) |
| | | | – | 0.4 | V | $I_{OL} = 5 \text{ mA}$ (5 V) $I_{OL} = 3.5 \text{ mA}$ (3.3 V) |
| Output low voltage on high current pads | V_{OLP1} | CC | – | 1.0 | V | $I_{OL} = 50 \text{ mA}$ (5 V) $I_{OL} = 25 \text{ mA}$ (3.3 V) |
| | | | – | 0.32 | V | $I_{OL} = 10 \text{ mA}$ (5 V) |
| | | | – | 0.4 | V | $I_{OL} = 5 \text{ mA}$ (3.3 V) |
| Output high voltage on port pins (with standard pads) | V_{OHP} | CC | $V_{DDP} - 1.0$ | – | V | $I_{OH} = -10 \text{ mA}$ (5 V) $I_{OH} = -7 \text{ mA}$ (3.3 V) |
| | | | $V_{DDP} - 0.4$ | – | V | $I_{OH} = -4.5 \text{ mA}$ (5 V) $I_{OH} = -2.5 \text{ mA}$ (3.3 V) |
| Output high voltage on high current pads | V_{OHP1} | CC | $V_{DDP} - 0.32$ | – | V | $I_{OH} = -6 \text{ mA}$ (5 V) |
| | | | $V_{DDP} - 1.0$ | – | V | $I_{OH} = -8 \text{ mA}$ (3.3 V) |
| | | | $V_{DDP} - 0.4$ | – | V | $I_{OH} = -4 \text{ mA}$ (3.3 V) |
| Input low voltage on port pins (Standard Hysteresis) | V_{ILPS} | SR | – | $0.19 \times V_{DDP}$ | V | CMOS Mode (5 V, 3.3 V & 2.2 V) |
| Input high voltage on port pins (Standard Hysteresis) | V_{IHPS} | SR | $0.7 \times V_{DDP}$ | – | V | CMOS Mode (5 V, 3.3 V & 2.2 V) |

Table 16 Input/Output Characteristics (Operating Conditions apply) (cont'd)

| Parameter | Symbol | | Limit Values | | Unit | Test Conditions |
|---|----------------------------|----|-----------------------|-----------------------|------|---|
| | | | Min. | Max. | | |
| Input low voltage on port pins (Large Hysteresis) | V_{ILPL} | SR | – | $0.08 \times V_{DDP}$ | V | CMOS Mode (5 V, 3.3 V & 2.2 V) |
| Input high voltage on port pins (Large Hysteresis) | V_{IHPL} | SR | $0.85 \times V_{DDP}$ | – | V | CMOS Mode (5 V, 3.3 V & 2.2 V) |
| Rise/fall time on High Current Pad ¹⁾ | t_{HCPR} , t_{HCPF} | CC | – | 9 | ns | 50 pF @ 5 V ²⁾ |
| | | | – | 12 | ns | 50 pF @ 3.3 V ³⁾ |
| | | | – | 25 | ns | 50 pF @ 1.8 V ⁴⁾ |
| Rise/fall time on Standard Pad ¹⁾ | t_R , t_F | CC | – | 12 | ns | 50 pF @ 5 V ⁵⁾ |
| | | | – | 15 | ns | 50 pF @ 3.3 V ⁶⁾ . |
| | | | – | 31 | ns | 50 pF @ 1.8 V ⁷⁾ . |
| Input Hysteresis on port pin except P2.3 - P2.9 ⁸⁾ | HYS | CC | $0.08 \times V_{DDP}$ | – | V | CMOS Mode (5 V), Standard Hysteresis |
| | | | $0.03 \times V_{DDP}$ | – | V | CMOS Mode (3.3 V), Standard Hysteresis |
| | | | $0.02 \times V_{DDP}$ | – | V | CMOS Mode (2.2 V), Standard Hysteresis |
| | | | $0.5 \times V_{DDP}$ | $0.75 \times V_{DDP}$ | V | CMOS Mode(5 V), Large Hysteresis |
| | | | $0.4 \times V_{DDP}$ | $0.75 \times V_{DDP}$ | V | CMOS Mode(3.3 V), Large Hysteresis |
| | | | $0.2 \times V_{DDP}$ | $0.65 \times V_{DDP}$ | V | CMOS Mode(2.2 V), Large Hysteresis |

Table 16 Input/Output Characteristics (Operating Conditions apply) (cont'd)

| Parameter | Symbol | Limit Values | Unit | Test Conditions | |
|---|----------------------|----------------------------|----------------------------|-----------------|---|
| | | | | Min. | Max. |
| Input Hysteresis on port pin P2.3 - P2.9 ⁸⁾ | HYS_ CC P2 | 0.08 × V _{DDP} | – | V | CMOS Mode (5 V), Standard Hysteresis |
| | | 0.03 × V _{DDP} | – | V | CMOS Mode (3.3 V), Standard Hysteresis |
| | | 0.02 × V _{DDP} | – | V | CMOS Mode (2.2 V), Standard Hysteresis |
| | | 0.35 × V _{DDP} | 0.75 × V _{DDP} | V | CMOS Mode(5 V), Large Hysteresis |
| | | 0.25 × V _{DDP} | 0.75 × V _{DDP} | V | CMOS Mode(3.3 V), Large Hysteresis |
| | | 0.15 × V _{DDP} | 0.65 × V _{DDP} | V | CMOS Mode(2.2 V), Large Hysteresis |
| Pin capacitance (digital inputs/outputs) | C _{IO} CC | – | 10 | pF | |
| Pull-up current on port pins | I _{PUP} CC | – | -80 | μA | V _{IH,min} (5 V) |
| | | -95 | – | μA | V _{IL,max} (5 V) |
| | | – | -50 | μA | V _{IH,min} (3.3 V) |
| | | -65 | – | μA | V _{IL,max} (3.3 V) |
| Pull-down current on port pins | I _{PDP} CC | – | 40 | μA | V _{IL,max} (5 V) |
| | | 95 | – | μA | V _{IH,min} (5 V) |
| | | – | 30 | μA | V _{IL,max} (3.3 V) |
| | | 60 | – | μA | V _{IH,min} (3.3 V) |
| Input leakage current except P0.11 ⁹⁾ | I _{OZP} CC | -1 | 1 | μA | 0 < V _{IN} < V _{DDP} , T _A ≤ 105 °C |
| Input leakage current for P0.11 ⁹⁾ | I _{OZP1} CC | -10 | 1 | μA | 0 < V _{IN} < V _{DDP} , T _A ≤ 105 °C |
| Voltage on any pin during V _{DDP} power off | V _{PO} SR | – | 0.3 | V | ¹⁰⁾ |
| Maximum current per pin (excluding P1, V _{DDP} and V _{SS}) | I _{MP} SR | -10 | 11 | mA | – |
| Maximum current per high current pins | I _{MP1A} SR | -10 | 50 | mA | – |

Table 16 Input/Output Characteristics (Operating Conditions apply) (cont'd)

| Parameter | Symbol | Limit Values | | Unit | Test Conditions |
|--|----------------|--------------|------|------|-----------------|
| | | Min. | Max. | | |
| Maximum current into V_{DDP} (VQFN64, LQFP64) | I_{MVDD1} SR | – | 520 | mA | |
| Maximum current into V_{DDP} (VQFN48) | I_{MVDD2} SR | – | 390 | mA | |
| Maximum current into V_{DDP} (VQFN40) | I_{MVDD3} SR | – | 260 | mA | |
| Maximum current out of V_{SS} (VQFN64, LQFP64) | I_{MVSS1} SR | – | 390 | mA | |
| Maximum current out of V_{SS} (VQFN48) | I_{MVSS2} SR | – | 260 | mA | |
| Maximum current out of V_{SS} (VQFN40) | I_{MVSS3} SR | – | 260 | mA | |

- 1) Rise/Fall time parameters are taken with 10% - 90% of supply.
- 2) Additional rise/fall time valid for $C_L = 50$ pF - $C_L = 100$ pF @ 0.150 ns/pF at 5 V supply voltage.
- 3) Additional rise/fall time valid for $C_L = 50$ pF - $C_L = 100$ pF @ 0.205 ns/pF at 3.3 V supply voltage.
- 4) Additional rise/fall time valid for $C_L = 50$ pF - $C_L = 100$ pF @ 0.445 ns/pF at 1.8 V supply voltage.
- 5) Additional rise/fall time valid for $C_L = 50$ pF - $C_L = 100$ pF @ 0.225 ns/pF at 5 V supply voltage.
- 6) Additional rise/fall time valid for $C_L = 50$ pF - $C_L = 100$ pF @ 0.288 ns/pF at 3.3 V supply voltage.
- 7) Additional rise/fall time valid for $C_L = 50$ pF - $C_L = 100$ pF @ 0.588 ns/pF at 1.8 V supply voltage.
- 8) Hysteresis is implemented to avoid meta stable states and switching due to internal ground bounce. It cannot be guaranteed that it suppresses switching due to external system noise.
- 9) An additional error current (I_{INJ}) will flow if an overload current flows through an adjacent pin.
- 10) However, for applications with strict low power-down current requirements, it is mandatory that no active voltage source is supplied at any GPIO pin when V_{DDP} is powered off.

3.2.2 Analog to Digital Converters (ADC)

Table 17 shows the Analog to Digital Converter (ADC) characteristics.

Note: These parameters are not subject to production test, but verified by design and/or characterization.

Table 17 ADC Characteristics (Operating Conditions apply)¹⁾

| Parameter | Symbol | Values | | | Unit | Note / Test Condition |
|---|---------------------|---------------------|------|---------------------|------|--|
| | | Min. | Typ. | Max. | | |
| Supply voltage range (internal reference) | V_{DD_int} SR | 2.0 | – | 3.0 | V | SHSCFG.AREF = 11 _B ; CALCTR.CALGNSTC = 0C _H for f_{SH} = 32 MHz, 12 _H for f_{SH} = 48 MHz |
| | | 3.0 | – | 5.5 | V | SHSCFG.AREF = 10 _B |
| Supply voltage range (external reference) | V_{DD_ext} SR | 3.0 | – | 5.5 | V | SHSCFG.AREF = 00 _B |
| Analog input voltage range | V_{AIN} SR | V_{SSP} - 0.05 | – | V_{DDP} + 0.05 | V | |
| Auxiliary analog reference ground ²⁾ | V_{REFGND} SR | V_{SSP} - 0.05 | – | 1.0 | V | G0CH0 |
| | | V_{SSP} - 0.05 | – | 0.2 | V | G1CH0 |
| Internal reference voltage (full scale value) | V_{REFINT} CC | 5 | | | V | |
| Switched capacitance of an analog input | C_{AINS} CC | – | 1.2 | 2 | pF | GNCTRxz.GAINy = 00 _B (unity gain) |
| | | – | 1.2 | 2 | pF | GNCTRxz.GAINy = 01 _B (gain g1) |
| | | – | 4.5 | 6 | pF | GNCTRxz.GAINy = 10 _B (gain g2) |
| | | – | 4.5 | 6 | pF | GNCTRxz.GAINy = 11 _B (gain g3) |
| Total capacitance of an analog input | C_{AINT} CC | – | – | 10 | pF | |
| Total capacitance of the reference input | C_{AREFT} CC | – | – | 10 | pF | |

Table 17 ADC Characteristics (Operating Conditions apply)¹⁾ (cont'd)

| Parameter | Symbol | Values | | | Unit | Note / Test Condition |
|--|------------------|--------|------|------------------|---------------|--|
| | | Min. | Typ. | Max. | | |
| Gain settings | $G_{IN\ CC}$ | 1 | | | – | GNCTR _{xz} .GAIN _y = 00 _B (unity gain) |
| | | 3 | | | – | GNCTR _{xz} .GAIN _y = 01 _B (gain g1) |
| | | 6 | | | – | GNCTR _{xz} .GAIN _y = 10 _B (gain g2) |
| | | 12 | | | – | GNCTR _{xz} .GAIN _y = 11 _B (gain g3) |
| Sample Time | $t_{sample\ CC}$ | 5 | – | – | 1 / f_{ADC} | $V_{DD} = 5.0\ V$, $f_{ADCI} = 48\ MHz$ |
| | | 3 | – | – | 1 / f_{ADC} | $V_{DD} = 5.0\ V$, $f_{ADCI} = 32\ MHz$ |
| | | 3 | – | – | 1 / f_{ADC} | $V_{DD} = 3.3\ V$, $f_{ADCI} = 32\ MHz$ |
| | | 30 | – | – | 1 / f_{ADC} | $V_{DD} = 2.0\ V$, $f_{ADCI} = 32\ MHz$ |
| Conversion time in fast compare mode | $t_{CF\ CC}$ | 9 | | | 1 / f_{ADC} | ³⁾ |
| Conversion time in 12-bit mode | $t_{C12\ CC}$ | 20 | | | 1 / f_{ADC} | ³⁾ |
| Maximum sample rate in 12-bit mode ⁴⁾ | $f_{C12\ CC}$ | – | – | $f_{ADC} / 42.5$ | – | 1 sample pending |
| | | – | – | $f_{ADC} / 62.5$ | – | 2 samples pending |
| Conversion time in 10-bit mode | $t_{C10\ CC}$ | 18 | | | 1 / f_{ADC} | ³⁾ |
| Maximum sample rate in 10-bit mode ⁴⁾ | $f_{C10\ CC}$ | – | – | $f_{ADC} / 40.5$ | – | 1 sample pending |
| | | – | – | $f_{ADC} / 58.5$ | – | 2 samples pending |
| Conversion time in 8-bit mode | $t_{C8\ CC}$ | 16 | | | 1 / f_{ADC} | ³⁾ |

Table 17 ADC Characteristics (Operating Conditions apply)¹⁾ (cont'd)

| Parameter | Symbol | Values | | | Unit | Note / Test Condition |
|--|----------------|--------|------|------------------|-----------|--|
| | | Min. | Typ. | Max. | | |
| Maximum sample rate in 8-bit mode ⁴⁾ | f_{C8} CC | – | – | $f_{ADC} / 38.5$ | – | 1 sample pending |
| | | – | – | $f_{ADC} / 54.5$ | – | 2 samples pending |
| RMS noise ⁵⁾ | EN_{RMS} CC | – | 1.5 | – | LSB 12 | DC input, SHSCFG.AREF = 00 _B , GNCTRz.GAINy = 00 _B (unity gain), $V_{DD} = 5.0$ V, $V_{AIN} = 2.5$ V, 25°C |
| DNL error | EA_{DNL} CC | – | ±2.0 | – | LSB 12 | |
| INL error | EA_{INL} CC | – | ±4.0 | – | LSB 12 | |
| Gain error with external reference | EA_{GAIN} CC | – | ±0.5 | – | % | SHSCFG.AREF = 00 _B (calibrated) |
| Gain error with internal reference ⁶⁾ | EA_{GAIN} CC | – | ±3.6 | – | % | SHSCFG.AREF = 1X _B (calibrated), -40°C - 110°C |
| | | – | ±2.0 | – | % | SHSCFG.AREF = 1X _B (calibrated), 0°C - 85°C |
| Offset error | EA_{OFF} CC | – | ±8.0 | – | mV | Calibrated, $V_{DD} = 5.0$ V |

1) The parameters are defined for ADC clock frequencies $f_{SH} = 32$ MHz for the full supply range, and $f_{SH} = 48$ MHz at V_{DD_int} , $V_{DD_ext} = 5$ V. Usage of any other frequencies may affect the ADC performance.

2) The alternate reference ground connection is separate for each converter. This mode, therefore, provides the lowest noise impact.

3) No pending samples assumed, excluding sampling time and calibration.

4) Includes synchronization and calibration (average of gain and offset calibration).

5) This parameter can also be defined as an SNR value: $SNR[dB] = 20 \times \log(A_{MAXeff} / N_{RMS})$.

With $A_{MAXeff} = 2^N / 2$, $SNR[dB] = 20 \times \log(2048 / N_{RMS})$ [$N = 12$].

$N_{RMS} = 1.5$ LSB12, therefore, equals $SNR = 20 \times \log(2048 / 1.5) = 62.7$ dB.

6) Includes error from the reference voltage.

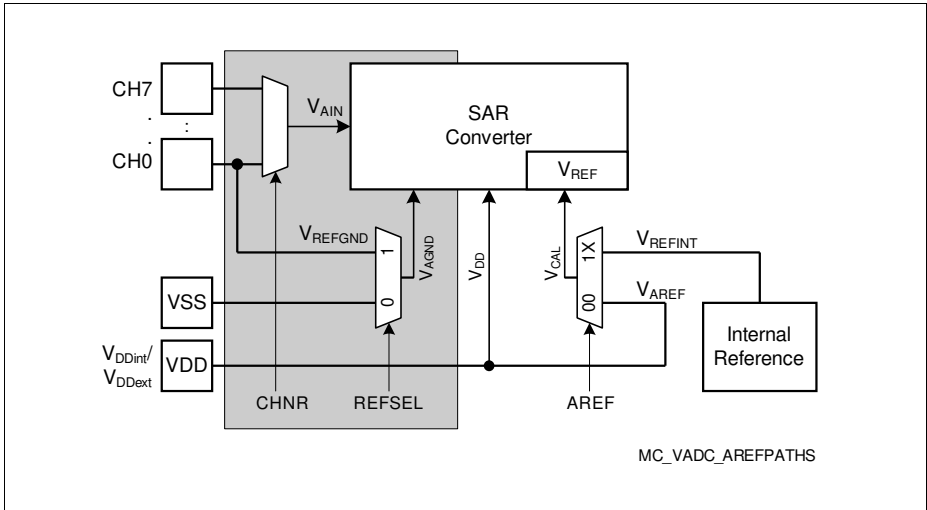

Figure 12 ADC Voltage Supply

3.2.3 Out of Range Comparator (ORC) Characteristics

The Out-of-Range Comparator (ORC) triggers on analog input voltages (V_{AIN}) above V_{DDP} on selected input pins (ORCx.AIN) and generates a service request trigger (ORCx.OUT).

Note: These parameters are not subject to production test, but verified by design and/or characterization.

Table 18 Out of Range Comparator (ORC) Characteristics (Operating Conditions apply; $V_{DDP} = 3.0\text{ V} - 5.5\text{ V}$; $C_L = 0.25\text{ pF}$)

| Parameter | Symbol | CC | Values | | | Unit | Note / Test Condition |
|-----------------------------------|------------|----|--------|------|------|------|---|
| | | | Min. | Typ. | Max. | | |
| DC Switching Level | V_{ODC} | CC | – | – | 180 | mV | $V_{AIN} \geq V_{DDP} + V_{ODC}$ |
| Hysteresis | V_{OHYS} | CC | 15 | – | 54 | mV | |
| Always detected Overvoltage Pulse | t_{OPDD} | CC | 103 | – | – | ns | $V_{AIN} \geq V_{DDP} + 150\text{ mV}$ |
| | | | 88 | – | – | ns | $V_{AIN} \geq V_{DDP} + 350\text{ mV}$ |
| Never detected Overvoltage Pulse | t_{OPDN} | CC | – | – | 21 | ns | $V_{AIN} \geq V_{DDP} + 150\text{ mV}$ |
| | | | – | – | 11 | ns | $V_{AIN} \geq V_{DDP} + 350\text{ mV}$ |
| Detection Delay | t_{ODD} | CC | 39 | – | 132 | ns | $V_{AIN} \geq V_{DDP} + 150\text{ mV}$ |
| | | | 31 | – | 121 | ns | $V_{AIN} \geq V_{DDP} + 350\text{ mV}$ |
| Release Delay | t_{ORD} | CC | 44 | – | 240 | ns | $V_{AIN} \leq V_{DDP}$; $V_{DDP} = 5\text{ V}$ |
| | | | 57 | – | 340 | ns | $V_{AIN} \leq V_{DDP}$; $V_{DDP} = 3.3\text{ V}$ |
| Enable Delay | t_{OED} | CC | – | – | 300 | ns | ORCCTRL.ENORCX = 1 |

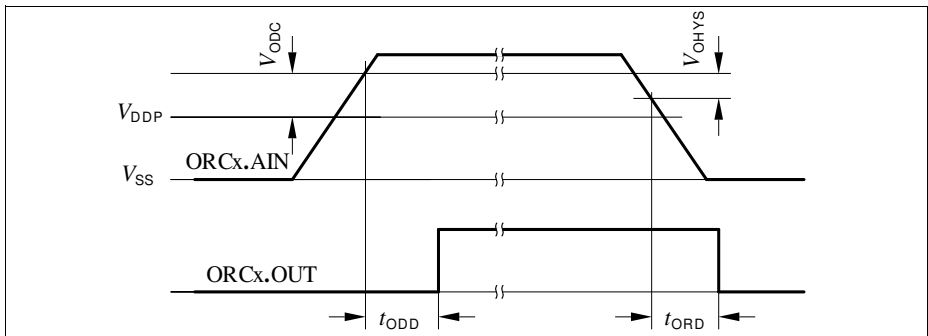

Figure 13 ORCx.OUT Trigger Generation

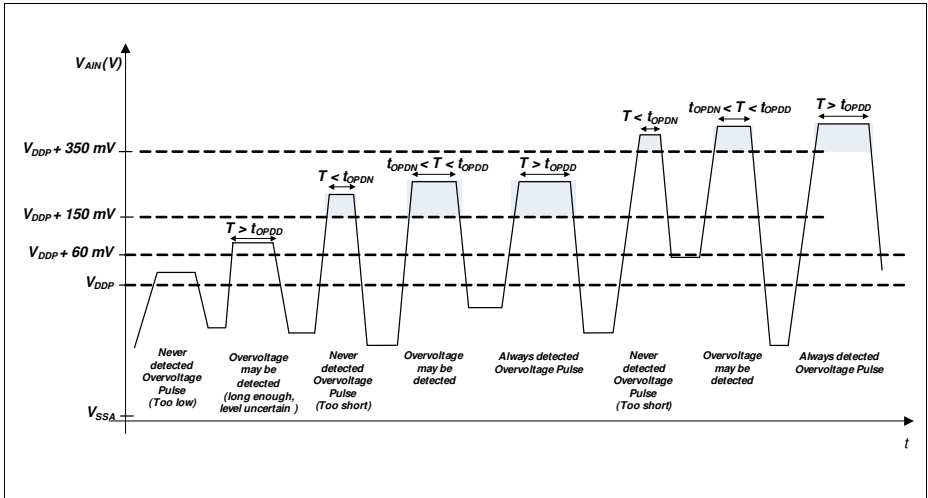

Figure 14 ORC Detection Ranges

3.2.4 Analog Comparator Characteristics

Table 19 below shows the Analog Comparator characteristics.

Note: These parameters are not subject to production test, but verified by design and/or characterization.

Table 19 Analog Comparator Characteristics (Operating Conditions apply)

| Parameter | Symbol | | Limit Values | | | Unit | Notes/ Test Conditions |
|---------------------------------|--------------|----|--------------|-------|------------------|---------|--|
| | | | Min. | Typ. | Max. | | |
| Input Voltage | V_{CMP} | SR | -0.05 | – | $V_{DDP} + 0.05$ | V | |
| Input Offset | V_{CMPOFF} | CC | – | +/-3 | – | mV | High power mode $\Delta V_{CMP} < 200$ mV |
| Propagation Delay ¹⁾ | t_{PDELAY} | CC | – | 25 | – | ns | High power mode, $\Delta V_{CMP} = 100$ mV |
| | | | – | 80 | – | ns | High power mode, $\Delta V_{CMP} = 25$ mV |
| | | | – | 250 | – | ns | Low power mode, $\Delta V_{CMP} = 100$ mV |
| | | | – | 700 | – | ns | Low power mode, $\Delta V_{CMP} = 25$ mV |
| Current Consumption | I_{ACMP} | CC | – | 100 | – | μ A | First active ACMP in high power mode, $\Delta V_{CMP} > 30$ mV |
| | | | – | 66 | – | μ A | Each additional ACMP in high power mode, $\Delta V_{CMP} > 30$ mV |
| | | | – | 10 | – | μ A | First active ACMP in low power mode |
| | | | – | 6 | – | μ A | Each additional ACMP in low power mode |
| Input Hysteresis | V_{HYS} | CC | – | +/-15 | – | mV | |
| Filter Delay ¹⁾ | t_{FDELAY} | CC | – | 5 | – | ns | |

1) Total Analog Comparator Delay is the sum of Propagation Delay and Filter Delay.

3.2.5 Temperature Sensor Characteristics

Note: These parameters are not subject to production test, but verified by design and/or characterization.

Table 20 Temperature Sensor Characteristics

| Parameter | Symbol | Values | | | Unit | Note / Test Condition |
|-------------------------------|------------------|--------|------|------|------|--|
| | | Min. | Typ. | Max. | | |
| Measurement time | t_M CC | – | – | 10 | ms | |
| Temperature sensor range | T_{SR} SR | -40 | – | 115 | °C | |
| Sensor Accuracy ¹⁾ | T_{TSAL} CC | -6 | – | 6 | °C | $T_J > 20^\circ\text{C}$ |
| | | -10 | – | 10 | °C | $0^\circ\text{C} \leq T_J \leq 20^\circ\text{C}$ |
| | | – | -/+8 | – | °C | $T_J < 0^\circ\text{C}$ |
| Start-up time | t_{TSST} SR | – | – | 15 | μs | |

1) The temperature sensor accuracy is independent of the supply voltage.

3.2.6 Oscillator Pins

Note: It is strongly recommended to measure the oscillation allowance (negative resistance) in the final target system (layout) to determine the optimal parameters for the oscillator operation. Please refer to the limits specified by the crystal or ceramic resonator supplier.

Note: These parameters are not subject to production test, but verified by design and/or characterization.

The oscillator pins can be operated with an external crystal/resonator (see [Figure 15](#)) or in direct input mode (see [Figure 16](#)).

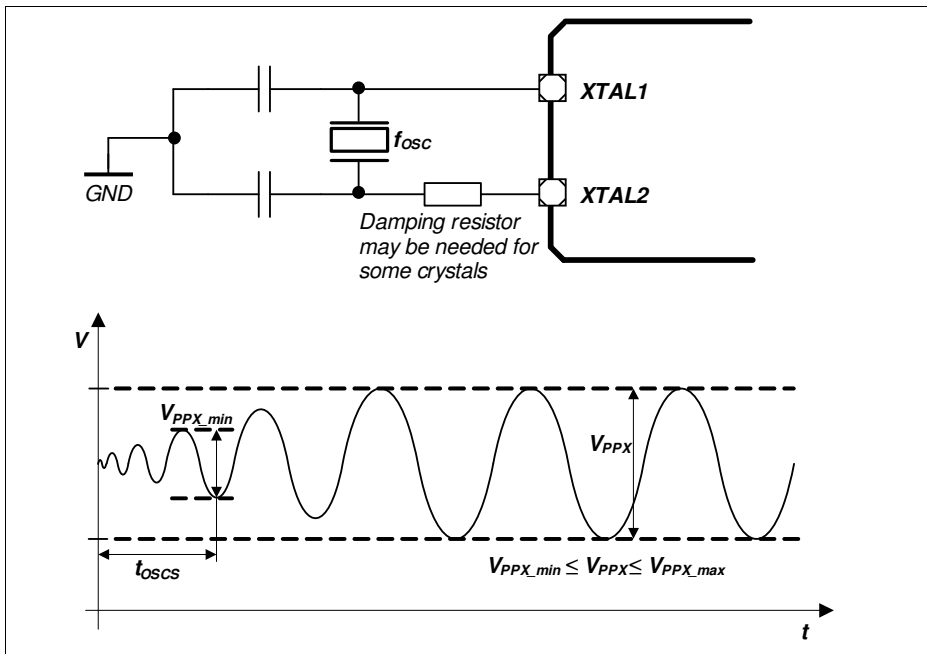

Figure 15 Oscillator in Crystal Mode

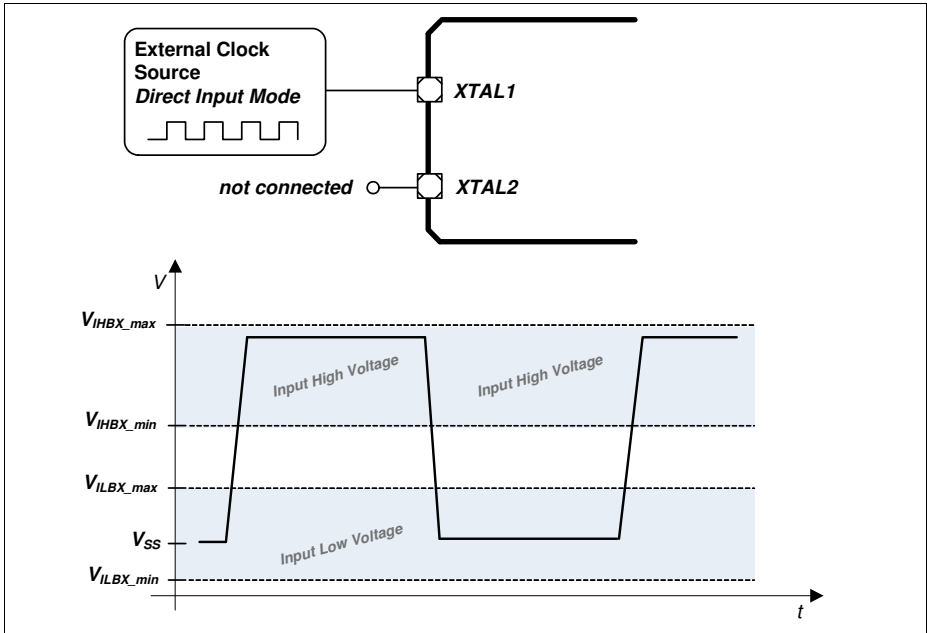

Figure 16 Oscillator in Direct Input Mode

Table 21 OSC_XTAL Parameters

| Parameter | Symbol | Values | | | Unit | Note / Test Condition |
|---|---------------|--------|------|------|------|-----------------------|
| | | Min. | Typ. | Max. | | |
| Input frequency | f_{OSC} SR | 4 | – | 48 | MHz | Direct Input Mode |
| | | 4 | – | 20 | MHz | External Crystal Mode |
| Oscillator start-up time ¹⁾²⁾ | t_{OSCS} CC | – | – | 10 | ms | |
| Input voltage at XTAL1 | V_{IX} SR | -0.3 | – | 1.5 | V | External Crystal Mode |
| | | -0.3 | – | 5.5 | V | Direct Input Mode |
| Input amplitude (peak-to-peak) at XTAL1 ²⁾³⁾ | V_{PPX} SR | 0.6 | – | 1.7 | V | External Crystal Mode |

1) t_{OSCS} is defined from the moment the oscillator is enabled with SCU_ANAOSCHPCTRL.MODE until the oscillations reach an amplitude at XTAL1 of $0.9 * V_{PPX}$.

2) The external oscillator circuitry must be optimized by the customer and checked for negative resistance and amplitude as recommended and specified by crystal suppliers.

3) If the shaper unit is enabled and not bypassed.

Table 22 RTC_XTAL Parameters

| Parameter | Symbol | Values | | | Unit | Note / Test Condition |
|---|------------------|--------|--------|------|------|--------------------------|
| | | Min. | Typ. | Max. | | |
| Input frequency | f_{OSC} SR | – | 32.768 | – | kHz | |
| Oscillator start-up time ¹⁾²⁾ | t_{OSCS} CC | – | – | 5 | s | |
| Input voltage at RTC_XTAL1 | V_{IX} SR | -0.3 | – | 1.5 | V | |
| Input amplitude (peak-to-peak) at RTC_XTAL1 ²⁾³⁾ | V_{PPX} SR | 0.2 | – | 1.2 | V | |

1) t_{OSCS} is defined from the moment the oscillator is enabled by the user with SCU_ANAOSCLPCTRL.MODE until the oscillations reach an amplitude at RTC_XTAL1 of $0.9 * V_{PPX}$.

2) The external oscillator circuitry must be optimized by the customer and checked for negative resistance and amplitude as recommended and specified by crystal suppliers.

3) If the shaper unit is enabled and not bypassed.

3.2.7 Power Supply Current

The total power supply current defined below consists of a leakage and a switching component.

Application relevant values are typically lower than those given in the following tables, and depend on the customer's system operating conditions (e.g. thermal connection or used application configurations).

Note: These parameters are not subject to production test, but verified by design and/or characterization.

Table 23 Power Supply parameter table; $V_{DDP} = 5V$

| Parameter | Symbol | Values | | | Unit | Note / Test Condition |
|--|----------------|--------|--------------------|------|------|-----------------------|
| | | Min. | Typ. ¹⁾ | Max. | | |
| Active mode current Peripherals enabled f_{MCLK} / f_{PCLK} in MHz ²⁾ | I_{DDPAE} CC | – | 14.1 | 20 | mA | 48 / 96 |
| | | – | 9.8 | – | mA | 24 / 48 |
| | | – | 7.8 | – | mA | 16 / 32 |
| | | – | 6.4 | – | mA | 8 / 16 |
| | | – | 4.4 | – | mA | 1 / 1 |
| Active mode current Peripherals disabled f_{MCLK} / f_{PCLK} in MHz ³⁾ | I_{DDPAD} CC | – | 6.2 | – | mA | 48 / 96 |
| | | – | 4.6 | – | mA | 24 / 48 |
| | | – | 3.6 | – | mA | 16 / 32 |
| | | – | 3.1 | – | mA | 8 / 16 |
| | | – | 1.8 | – | mA | 1 / 1 |
| Active mode current Code execution from RAM Flash is powered down f_{MCLK} / f_{PCLK} in MHz | I_{DDPAR} CC | – | 9.6 | – | mA | 48 / 96 |
| Sleep mode current Peripherals clock enabled f_{MCLK} / f_{PCLK} in MHz ⁴⁾ | I_{DDPSE} CC | – | 11.0 | – | mA | 48 / 96 |
| | | – | 7.6 | – | mA | 24 / 48 |
| | | – | 6.4 | – | mA | 16 / 32 |
| | | – | 5.3 | – | mA | 8 / 16 |
| | | – | 4.2 | – | mA | 1 / 1 |

Table 23 Power Supply parameter table; $V_{DDP} = 5V$

| Parameter | Symbol | Values | | | Unit | Note / Test Condition |
|---|-------------------|--------|--------------------|------|--------|-----------------------|
| | | Min. | Typ. ¹⁾ | Max. | | |
| Sleep mode current Peripherals clock disabled Flash active f_{MCLK} / f_{PCLK} in MHz ⁵⁾ | I_{DDPSD} CC | – | 2.8 | – | mA | 48 / 96 |
| | | – | 2.2 | – | mA | 24 / 48 |
| | | – | 2.0 | – | mA | 16 / 32 |
| | | – | 1.9 | – | mA | 8 / 16 |
| | | – | 1.7 | – | mA | 1 / 1 |
| Sleep mode current Peripherals clock disabled Flash powered down f_{MCLK} / f_{PCLK} in MHz ⁶⁾ | I_{DDPSR} CC | – | 2.2 | – | mA | 48 / 96 |
| | | – | 1.7 | – | mA | 24 / 48 |
| | | – | 1.4 | – | mA | 16 / 32 |
| | | – | 1.2 | – | mA | 8 / 16 |
| | | – | 1.1 | – | mA | 1 / 1 |
| Deep Sleep mode current ⁷⁾ | I_{DDPDS} CC | – | 0.27 | – | mA | |
| Wake-up time from Sleep to Active mode ⁸⁾ | t_{SSA} CC | – | 6 | – | cycles | |
| Wake-up time from Deep Sleep to Active mode ⁹⁾ | t_{DSA} CC | – | 290 | – | μsec | |

1) The typical values are measured at $T_A = +25\text{ °C}$ and $V_{DDP} = 5V$.

2) CPU and all peripherals clock enabled, Flash is in active mode.

3) CPU enabled, all peripherals clock disabled, Flash is in active mode.

4) CPU in sleep, all peripherals clock enabled and Flash is in active mode.

5) CPU in sleep, Flash is in active mode.

6) CPU in sleep, Flash is powered down and code executed from RAM after wake-up.

7) CPU in sleep, peripherals clock disabled, Flash is powered down and code executed from RAM after wake-up.

8) CPU in sleep, Flash is in active mode during sleep mode.

9) CPU in sleep, Flash is in powered down mode during deep sleep mode.

Figure 17 shows typical graphs for active mode supply current for $V_{DDP} = 5\text{ V}$, $V_{DDP} = 3.3\text{ V}$, $V_{DDP} = 1.8\text{ V}$ across different clock frequencies.

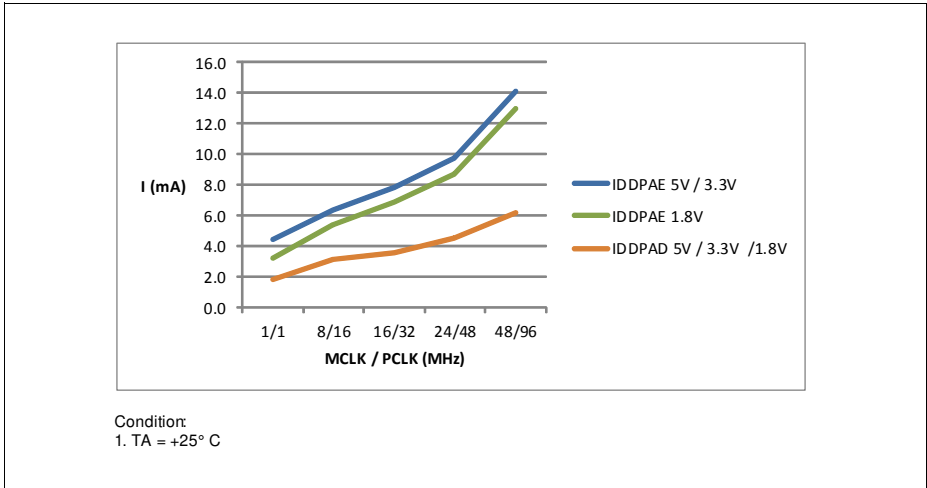
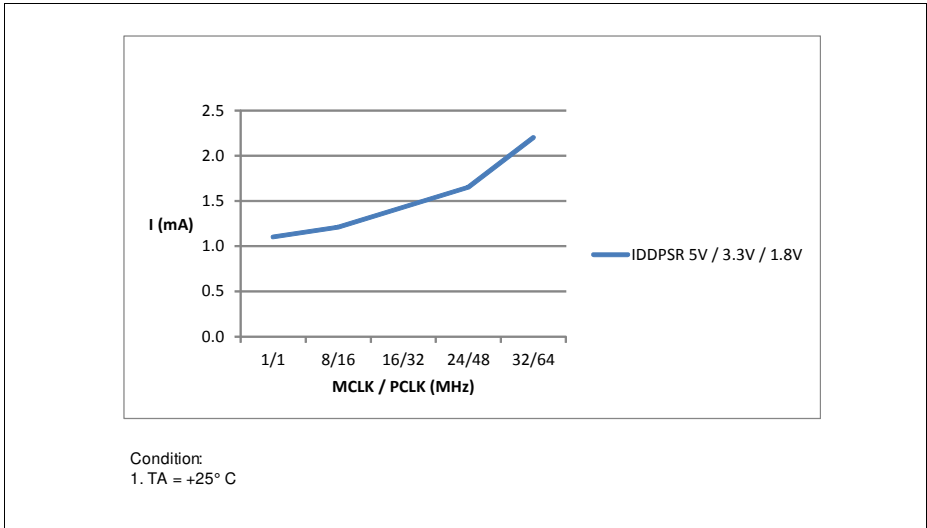

Figure 17 Active mode, a) peripherals clocks enabled, b) peripherals clocks disabled: Supply current I_{DDPA} over supply voltage V_{DDP} for different clock frequencies

Figure 18 shows typical graphs for sleep mode current for $V_{DDP} = 5\text{ V}$, $V_{DDP} = 3.3\text{ V}$, $V_{DDP} = 1.8\text{ V}$ across different clock frequencies.



**Figure 18 Sleep mode, peripherals clocks disabled, Flash powered down:
Supply current I_{DDPSD} over supply voltage V_{DDP} for different clock frequencies**

Table 24 provides the active current consumption of some modules operating at 5 V power supply at 25 °C. The typical values shown are used as a reference guide on the current consumption when these modules are enabled.

Table 24 Typical Active Current parameter table

| Active Current Consumption | Symbol | Limit Values | Unit | Test Condition |
|----------------------------|-----------------------|--------------|------|---|
| | | Typ. | | |
| Baseload current | I_{CPUDDC} | 4.14 | mA | Modules including Core, SCU, PORT, memories, ANATOP ¹⁾ |
| VADC and SHS | I_{ADCDDC} | 3.73 | mA | Set CGATCLR0.VADC to 1 ²⁾ |
| USICx | I_{USIC0DDC} | 1.35 | mA | Set CGATCLR0.USIC0 to 1 ³⁾ |
| CCU4x | I_{CCU40DDC} | 0.99 | mA | Set CGATCLR0.CCU40 to 1 ⁴⁾ |
| CCU8x | I_{CCU80DDC} | 1.00 | mA | Set CGATCLR0.CCU80 to 1 ⁵⁾ |
| POSIFx | I_{PIF0DDC} | 1.05 | mA | Set CGATCLR0.POSIF0 to 1 ⁶⁾ |
| LEDTSx | I_{LTSxDDC} | 1.14 | mA | Set CGATCLR0.LEDTSx to 1 ⁷⁾ |
| BCCU0 | I_{BCCU0DDC} | 0.29 | mA | Set CGATCLR0.BCCU0 to 1 ⁸⁾ |
| MATH | I_{MATHDDC} | 0.50 | mA | Set CGATCLR0.MATH to 1 ⁹⁾ |
| WDT | I_{WDTDDC} | 0.03 | mA | Set CGATCLR0.WDT to 1 ¹⁰⁾ |
| RTC | I_{RTCDDC} | 0.01 | mA | Set CGATCLR0.RTC to 1 ¹¹⁾ |
| MultiCAN | I_{MCANDDC} | 1.38 | mA | Set CGATCLR0.MCAN0 to 1 ¹²⁾ |

1) Baseload current is measured with device running in user mode, MCLK=PCLK=48 MHz, with an endless loop in the flash memory. The clock to the modules stated in CGATSTAT0 are gated.

2) Active current is measured with: module enabled, MCLK=48 MHz, running in auto-scan conversion mode

3) Active current is measured with: module enabled, each of the 2 USIC channels sending alternate messages at 57.6 kbaud every 200 ms

4) Active current is measured with: module enabled, MCLK=PCLK=48 MHz, 1 CCU4 slice for PWM switching at 20kHz with duty cycle varying at 10%-90%, 1 CCU4 slice in capture mode for reading period and duty cycle

5) Active current is measured with: module enabled, MCLK=PCLK=48 MHz, 3 CCU8 slices with PWM frequency at 20kHz and a period match interrupt used to toggle duty cycle between 10% and 90%

6) Active current is measured with: module enabled, MCLK=48 MHz, PCLK=96 MHz, hall sensor mode

7) Active current is measured with: module enabled, MCLK=48 MHz, 1 LED column, 6 LED/TS lines, Pad Scheme A with large pad hysteresis config, time slice duration = 1.048 ms

8) Active current is measured with: module enabled, MCLK=48 MHz, PCLK=96MHz, FCLK=0.8 MHz, Normal mode (BCCU clock = FCLK/4), 4 BCCU Channels with packers enabled and 1 Dimming Engine, change color or dim every 1s

9) Active current is measured with: module enabled, MCLK=48 MHz, PCLK=96 MHz, tangent calculation in while loop; CORDIC circular rotation, no keep, autostart; 32-by-32 bit signed DIV, autostart, DVS right shift by 11

Electrical Parameter

- 10) Active current is measured with: module enabled, MCLK=48 MHz, time-out mode; WLB = 0, WUB = 0x00008000; WDT serviced every 1 s
- 11) Active current is measured with: module enabled, MCLK=48 MHz, Periodic interrupt enabled
- 12) Active current is measured with: module enabled, MCLK=48 MHz, running at 20 MHz baudrate generator, 1 node activated, 1 transmit and 1 receive object active.

3.2.8 Flash Memory Parameters

Note: These parameters are not subject to production test, but verified by design and/or characterization.

Table 25 Flash Memory Parameters

| Parameter | Symbol | Values | | | Unit | Note / Test Condition |
|---------------------------------|-------------------------|--------|------|----------------|---------------|-------------------------------------|
| | | Min. | Typ. | Max. | | |
| Erase time per page / sector | $t_{\text{ERASE CC}}$ | 6.8 | 7.1 | 7.6 | ms | |
| Program time per block | $t_{\text{PSEB CC}}$ | 102 | 152 | 204 | μs | |
| Wake-Up time | $t_{\text{WU CC}}$ | – | 32.2 | – | μs | |
| Read time per word | $t_{\text{a CC}}$ | – | 50 | – | ns | |
| Data Retention Time | $t_{\text{RET CC}}$ | 10 | – | – | years | Max. 100 erase / program cycles |
| Flash Wait States ¹⁾ | $N_{\text{WSFLASH CC}}$ | 0 | 0 | 0 | | $f_{\text{MCLK}} = 8 \text{ MHz}$ |
| | | 0 | 1 | 1 | | $f_{\text{MCLK}} = 16 \text{ MHz}$ |
| | | 1 | 2 | 2 | | $f_{\text{MCLK}} = 32 \text{ MHz}$ |
| | | 2 | 2 | 3 | | $f_{\text{MCLK}} = 48 \text{ MHz}$ |
| Erase Cycles | $N_{\text{ECYC CC}}$ | – | – | $5 \cdot 10^4$ | cycles | Sum of page and sector erase cycles |
| Total Erase Cycles | $N_{\text{TECYC CC}}$ | – | – | $2 \cdot 10^6$ | cycles | |

1) Flash wait states are automatically inserted by the Flash module during memory read when needed. Typical values are calculated from the execution of the Dhrystone benchmark program.

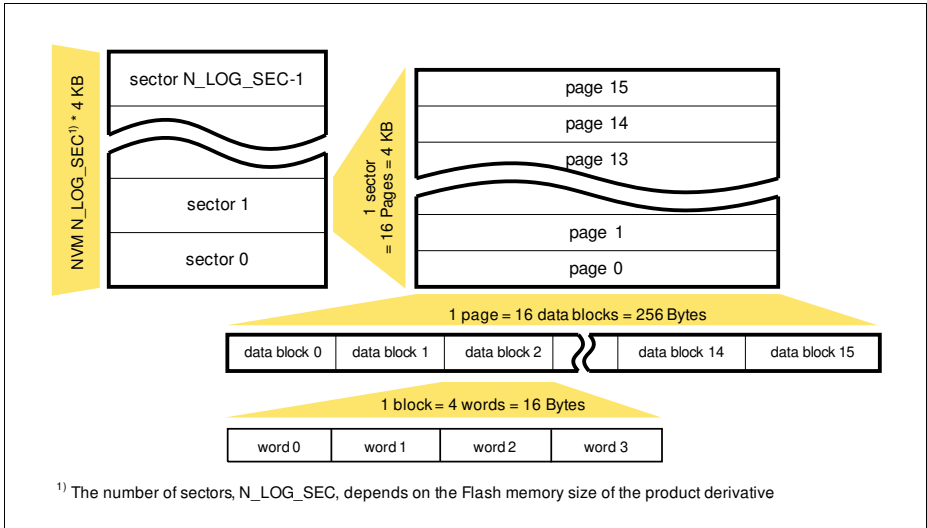

Figure 19 Logical Structure of the Flash

3.3 AC Parameters

3.3.1 Testing Waveforms

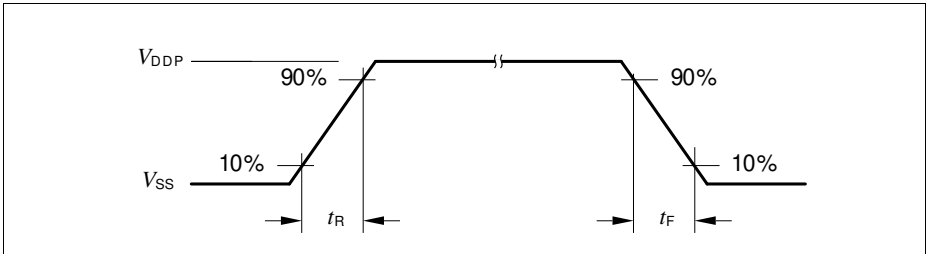

Figure 20 Rise/Fall Time Parameters

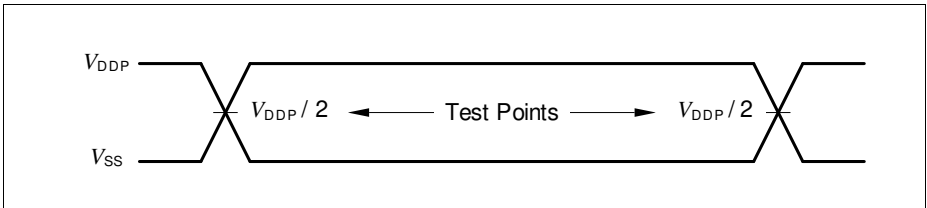

Figure 21 Testing Waveform, Output Delay

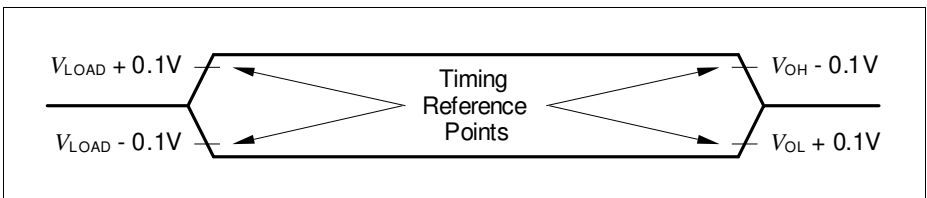

Figure 22 Testing Waveform, Output High Impedance

3.3.2 Power-Up and Supply Threshold Characteristics

Table 26 provides the characteristics of the supply threshold in XMC1400.

The guard band between the lowest valid operating voltage and the brownout reset threshold provides a margin for noise immunity and hysteresis. The electrical parameters may be violated while V_{DDP} is outside its operating range.

The brownout detection triggers a reset within the defined range. The prewarning detection can be used to trigger an early warning and issue corrective and/or fail-safe actions in case of a critical supply voltage drop.

Note: These parameters are not subject to production test, but verified by design and/or characterization.

Table 26 Power-Up and Supply Threshold Parameters (Operating Conditions apply)

| Parameter | Symbol | Values | | | Unit | Note / Test Condition |
|------------------------------|-------------------------------|-------------------------------|------|--------|------------------------|---|
| | | Min. | Typ. | Max. | | |
| V_{DDP} ramp-up time | $t_{RAMPU\text{P}}$ SR | $V_{DDP}/S_{VDDP\text{rise}}$ | – | 10^7 | μs | |
| V_{DDP} slew rate | $S_{VDDP\text{OP}}$ SR | 0 | – | 0.1 | $\text{V}/\mu\text{s}$ | Slope during normal operation |
| | S_{VDDP10} SR | 0 | – | 10 | $\text{V}/\mu\text{s}$ | Slope during fast transient within +/- 10% of V_{DDP} |
| | $S_{VDDP\text{rise}}$ SR | 0 | – | 10 | $\text{V}/\mu\text{s}$ | Slope during power-on or restart after brownout event |
| | $S_{VDDP\text{fall}}^{1)}$ SR | 0 | – | 0.25 | $\text{V}/\mu\text{s}$ | Slope during supply falling out of the +/- 10% limits ²⁾ |
| V_{DDP} prewarning voltage | $V_{DDP\text{PW}}$ CC | 2.1 | 2.25 | 2.4 | V | ANAVDEL.VDEL_SELECT = 00 _B |
| | | 2.85 | 3 | 3.15 | V | ANAVDEL.VDEL_SELECT = 01 _B |
| | | 4.2 | 4.4 | 4.6 | V | ANAVDEL.VDEL_SELECT = 10 _B |

Table 26 Power-Up and Supply Threshold Parameters (Operating Conditions apply) (cont'd)

| Parameter | Symbol | Values | | | Unit | Note / Test Condition |
|--|----------------|--------|------|------|---------|---|
| | | Min. | Typ. | Max. | | |
| V_{DDP} brownout reset voltage | V_{DDPBO} CC | 1.55 | 1.62 | 1.75 | V | calibrated, before user code starts running |
| V_{DDP} voltage to ensure defined pad states | V_{DDPPA} CC | – | 1.0 | – | V | |
| Start-up time from power-on reset | t_{SSW} SR | – | 260 | – | μ s | Time to the first user code instruction ³⁾ |
| BMI program time | t_{BMI} SR | – | 8.25 | – | ms | Time taken from a user-triggered system reset after BMI installation is requested |

1) A capacitor of at least 100 nF has to be added between V_{DDP} and V_{SSP} to fulfill the requirement as stated for this parameter.

2) Valid for a 100 nF buffer capacitor connected to supply pin where current from capacitor is forwarded only to the chip. A larger capacitor value has to be chosen if the power source sink a current.

3) This values does not include the ramp-up time. During startup firmware execution, MCLK is running at 48 MHz and the clocks to peripheral as specified in register CGATSTAT0 are gated.

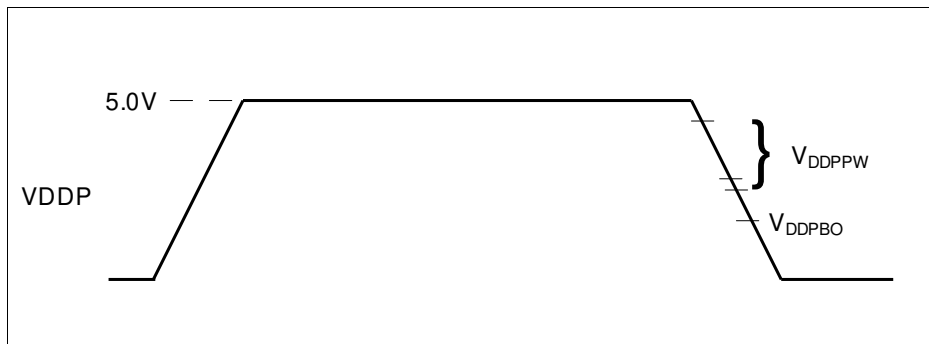

Figure 23 Supply Threshold Parameters

3.3.3 On-Chip Oscillator Characteristics

Table 27 provides the characteristics of the 96 MHz digital controlled oscillator DCO1.

Note: These parameters are not subject to production test, but verified by design and/or characterization.

Table 27 96 MHz DCO1 Characteristics (Operating Conditions apply)

| Parameter | Symbol | | Limit Values | | | Unit | Test Conditions |
|---|-------------------------|----|--------------|-----|------|------|--|
| | | | Min. | Typ | Max. | | |
| Nominal frequency | f_{NOM} | CC | — | 96 | — | MHz | under nominal conditions ¹⁾ after trimming |
| Accuracy with adjustment based on XTAL as reference | Δf_{LTX} | CC | -0.3 | — | 0.3 | % | with respect to $f_{\text{NOM}}(\text{typ})$, over temperature (-40 °C to 105 °C) |
| Accuracy | Δf_{LT} | CC | -1.7 | — | 3.4 | % | with respect to $f_{\text{NOM}}(\text{typ})$, over temperature (0 °C to 85 °C) |
| | | | -3.9 | — | 4.0 | % | with respect to $f_{\text{NOM}}(\text{typ})$, over temperature (-40 °C to 105 °C) |

1) The deviation is relative to the factory trimmed frequency at nominal V_{DDC} and $T_{\text{A}} = +25$ °C.

Table 28 provides the characteristics of the 32 kHz digital controlled oscillator DCO2.

Table 28 32 kHz DCO2 Characteristics (Operating Conditions apply)

| Parameter | Symbol | | Limit Values | | | Unit | Test Conditions |
|-------------------|------------------------|----|--------------|-------|------|------|--|
| | | | Min. | Typ. | Max. | | |
| Nominal frequency | f_{NOM} | CC | — | 32.75 | — | kHz | under nominal conditions ¹⁾ after trimming |
| Accuracy | Δf_{LT} | CC | -1.7 | — | 3.4 | % | with respect to $f_{\text{NOM}}(\text{typ})$, over temperature (0 °C to 85 °C) |
| | | | -3.9 | — | 4.0 | % | with respect to $f_{\text{NOM}}(\text{typ})$, over temperature (-40 °C to 105 °C) ¹⁾ |

1) The deviation is relative to the factory trimmed frequency at nominal V_{DDC} and $T_{\text{A}} = +25$ °C.

3.3.4 Serial Wire Debug Port (SW-DP) Timing

The following parameters are applicable for communication through the SW-DP interface.

Note: These parameters are not subject to production test, but verified by design and/or characterization.

Table 29 SWD Interface Timing Parameters(Operating Conditions apply)

| Parameter | Symbol | Values | | | Unit | Note / Test Condition |
|--|----------|--------|------|--------|------|-----------------------|
| | | Min. | Typ. | Max. | | |
| SWDCLK high time | t_1 SR | 50 | – | 500000 | ns | – |
| SWDCLK low time | t_2 SR | 50 | – | 500000 | ns | – |
| SWDIO input setup to SWDCLK rising edge | t_3 SR | 10 | – | – | ns | – |
| SWDIO input hold after SWDCLK rising edge | t_4 SR | 10 | – | – | ns | – |
| SWDIO output valid time after SWDCLK rising edge | t_5 CC | – | – | 68 | ns | $C_L = 50$ pF |
| | | – | – | 62 | ns | $C_L = 30$ pF |
| SWDIO output hold time from SWDCLK rising edge | t_6 CC | 4 | – | – | ns | |

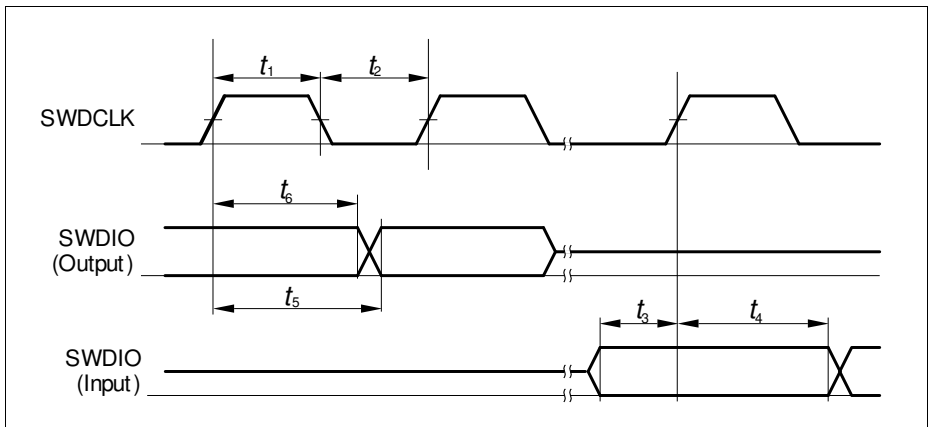

Figure 24 SWD Timing

3.3.5 SPD Timing Requirements

The optimum SPD decision time between 0_B and 1_B is $0.75 \mu\text{s}$. With this value the system has maximum robustness against frequency deviations of the sampling clock on tool and on device side. However it is not always possible to exactly match this value with the given constraints for the sample clock. For instance for a oversampling rate of 4, the sample clock will be 8 MHz and in this case the closest possible effective decision time is 5.5 clock cycles ($0.69 \mu\text{s}$).

Table 30 Optimum Number of Sample Clocks for SPD

| Sample Freq. | Sampling Factor | Sample Clocks 0_B | Sample Clocks 1_B | Effective Decision Time ¹⁾ | Remark |
|--------------|-----------------|---------------------|---------------------|---------------------------------------|---|
| 8 MHz | 4 | 1 to 5 | 6 to 12 | $0.69 \mu\text{s}$ | The other closest option ($0.81 \mu\text{s}$) for the effective decision time is less robust. |

1) Nominal sample frequency period multiplied with $0.5 + (\text{max. number of } 0_B \text{ sample clocks})$

For a balanced distribution of the timing robustness of SPD between tool and device, the timing requirements for the tool are:

- Frequency deviation of the sample clock is $\pm 5\%$
- Effective decision time is between $0.69 \mu\text{s}$ and $0.75 \mu\text{s}$ (calculated with nominal sample frequency)

3.3.6 Peripheral Timings

Note: These parameters are not subject to production test, but verified by design and/or characterization.

3.3.6.1 Synchronous Serial Interface (USIC SSC) Timing

The following parameters are applicable for a USIC channel operated in SSC mode.

Note: Operating Conditions apply.

Table 31 USIC SSC Master Mode Timing

| Parameter | Symbol | Values | | | Unit | Note / Test Condition |
|---|--------------|------------------|------|------|------|-----------------------|
| | | Min. | Typ. | Max. | | |
| SCLKOUT master clock period | t_{CLK} CC | 4/MCLK | – | – | ns | |
| Slave select output SELO active to first SCLKOUT transmit edge | t_1 CC | $t_{CLK}/2 - 28$ | – | – | ns | |
| Slave select output SELO inactive after last SCLKOUT receive edge | t_2 CC | 0 | – | – | ns | |
| Data output DOUT[3:0] valid time | t_3 CC | -28 | – | 28 | ns | |
| Receive data input DX0/DX[5:3] setup time to SCLKOUT receive edge | t_4 SR | 75 | – | – | ns | |
| Data input DX0/DX[5:3] hold time from SCLKOUT receive edge | t_5 SR | 0 | – | – | ns | |

Table 32 USIC SSC Slave Mode Timing

| Parameter | Symbol | Values | | | Unit | Note / Test Condition |
|---|--------------|--------|------|------|------|-----------------------|
| | | Min. | Typ. | Max. | | |
| DX1 slave clock period | t_{CLK} SR | 4/MCLK | – | – | ns | |
| Select input DX2 setup to first clock input DX1 transmit edge ¹⁾ | t_{10} SR | 16 | – | – | ns | |

Table 32 USIC SSC Slave Mode Timing

| Parameter | Symbol | Values | | | Unit | Note / Test Condition |
|---|----------------|--------|------|------|------|-----------------------|
| | | Min. | Typ. | Max. | | |
| Select input DX2 hold after last clock input DX1 receive edge ¹⁾ | t_{11} SR | 17 | – | – | ns | |
| Receive data input DX0/DX[5:3] setup time to shift clock receive edge ¹⁾ | t_{12} SR | 21 | – | – | ns | |
| Data input DX0/DX[5:3] hold time from clock input DX1 receive edge ¹⁾ | t_{13} SR | 15 | – | – | ns | |
| Data output DOUT[3:0] valid time | t_{14} CC | - | – | 71 | ns | |

1) These input timings are valid for asynchronous input signal handling of slave select input, shift clock input, and receive data input (bits DXnCR.DSEN = 0).

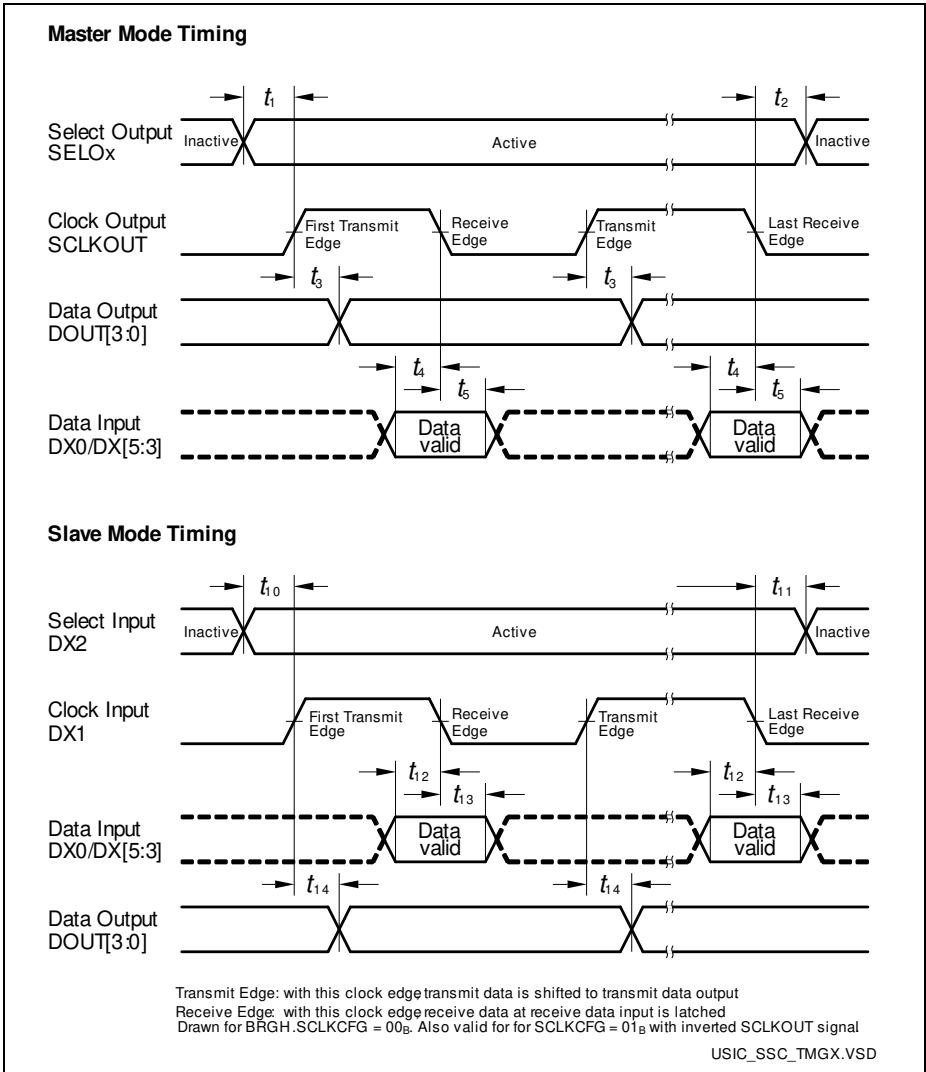

Figure 25 USIC - SSC Master/Slave Mode Timing

Note: This timing diagram shows a standard configuration, for which the slave select signal is low-active, and the serial clock signal is not shifted and not inverted.

3.3.6.2 Inter-IC (IIC) Interface Timing

The following parameters are applicable for a USIC channel operated in IIC mode.

Note: Operating Conditions apply.

Table 33 USIC IIC Standard Mode Timing¹⁾

| Parameter | Symbol | Values | | | Unit | Note / Test Condition |
|--|-------------------|--------|------|------|------|-----------------------|
| | | Min. | Typ. | Max. | | |
| Fall time of both SDA and SCL | t_1 CC/SR | - | - | 300 | ns | |
| Rise time of both SDA and SCL | t_2 CC/SR | - | - | 1000 | ns | |
| Data hold time | t_3 CC/SR | 0 | - | - | μs | |
| Data set-up time | t_4 CC/SR | 250 | - | - | ns | |
| LOW period of SCL clock | t_5 CC/SR | 4.7 | - | - | μs | |
| HIGH period of SCL clock | t_6 CC/SR | 4.0 | - | - | μs | |
| Hold time for (repeated) START condition | t_7 CC/SR | 4.0 | - | - | μs | |
| Set-up time for repeated START condition | t_8 CC/SR | 4.7 | - | - | μs | |
| Set-up time for STOP condition | t_9 CC/SR | 4.0 | - | - | μs | |
| Bus free time between a STOP and START condition | t_{10} CC/SR | 4.7 | - | - | μs | |
| Capacitive load for each bus line | C_b SR | - | - | 400 | pF | |

1) Due to the wired-AND configuration of an IIC bus system, the port drivers of the SCL and SDA signal lines need to operate in open-drain mode. The high level on these lines must be held by an external pull-up device, approximately 10 kOhm for operation at 100 kbit/s, approximately 2 kOhm for operation at 400 kbit/s.

Table 34 USIC IIC Fast Mode Timing¹⁾

| Parameter | Symbol | Values | | | Unit | Note / Test Condition |
|--|-------------------|--|------|------|------|-----------------------|
| | | Min. | Typ. | Max. | | |
| Fall time of both SDA and SCL | t_1 CC/SR | 20 + $0.1 \cdot C_b$ ²⁾ | - | 300 | ns | |
| Rise time of both SDA and SCL | t_2 CC/SR | 20 + $0.1 \cdot C_b$ | - | 300 | ns | |
| Data hold time | t_3 CC/SR | 0 | - | - | μs | |
| Data set-up time | t_4 CC/SR | 100 | - | - | ns | |
| LOW period of SCL clock | t_5 CC/SR | 1.3 | - | - | μs | |
| HIGH period of SCL clock | t_6 CC/SR | 0.6 | - | - | μs | |
| Hold time for (repeated) START condition | t_7 CC/SR | 0.6 | - | - | μs | |
| Set-up time for repeated START condition | t_8 CC/SR | 0.6 | - | - | μs | |
| Set-up time for STOP condition | t_9 CC/SR | 0.6 | - | - | μs | |
| Bus free time between a STOP and START condition | t_{10} CC/SR | 1.3 | - | - | μs | |
| Capacitive load for each bus line | C_b SR | - | - | 400 | pF | |

1) Due to the wired-AND configuration of an IIC bus system, the port drivers of the SCL and SDA signal lines need to operate in open-drain mode. The high level on these lines must be held by an external pull-up device, approximately 10 kOhm for operation at 100 kbit/s, approximately 2 kOhm for operation at 400 kbit/s.

2) C_b refers to the total capacitance of one bus line in pF.

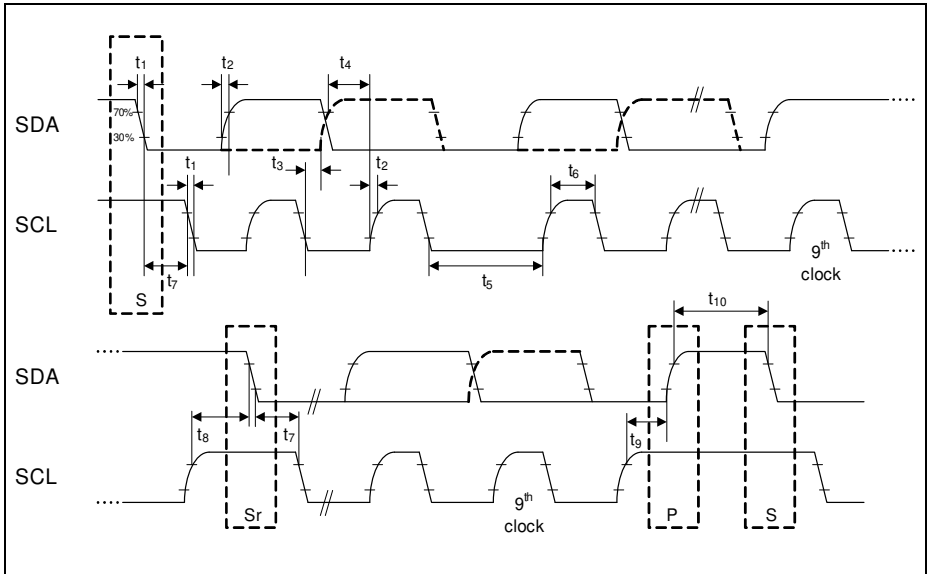

Figure 26 USIC IIC Timing

3.3.6.3 Inter-IC Sound (IIS) Interface Timing

The following parameters are applicable for a USIC channel operated in IIS mode.

Note: Operating Conditions apply.

Table 35 USIC IIS Master Transmitter Timing

| Parameter | Symbol | Values | | | Unit | Note / Test Condition |
|-----------------|----------|------------------------|------|------------------------|------|-----------------------|
| | | Min. | Typ. | Max. | | |
| Clock period | t_1 CC | $4/f_{MCLK}$ | - | - | ns | |
| Clock HIGH | t_2 CC | $0.35 \times t_{1min}$ | - | - | ns | |
| Clock Low | t_3 CC | $0.35 \times t_{1min}$ | - | - | ns | |
| Hold time | t_4 CC | 0 | - | - | ns | |
| Clock rise time | t_5 CC | - | - | $0.15 \times t_{1min}$ | ns | |

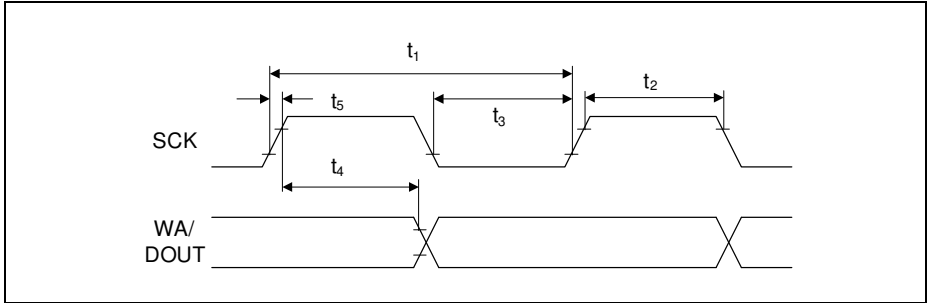

Figure 27 USIC IIS Master Transmitter Timing

Table 36 USIC IIS Slave Receiver Timing

| Parameter | Symbol | Values | | | Unit | Note / Test Condition |
|--------------|-------------|------------------------|------|------|------|-----------------------|
| | | Min. | Typ. | Max. | | |
| Clock period | t_6 SR | $4/f_{MCLK}$ | - | - | ns | |
| Clock HIGH | t_7 SR | $0.35 \times t_{6min}$ | - | - | ns | |
| Clock Low | t_8 SR | $0.35 \times t_{6min}$ | - | - | ns | |
| Set-up time | t_9 SR | $0.3 \times t_{6min}$ | - | - | ns | |
| Hold time | t_{10} SR | 15 | - | - | ns | |

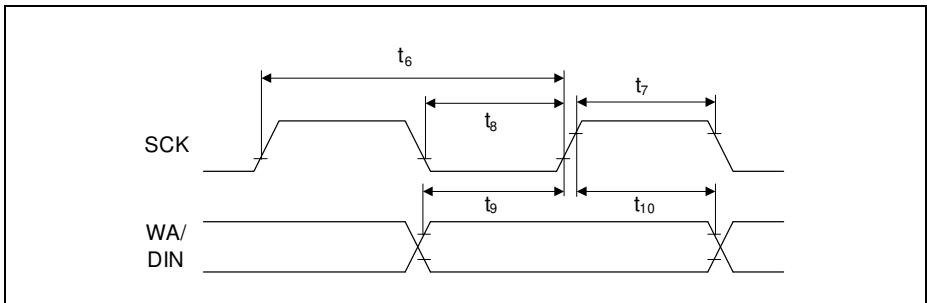

Figure 28 USIC IIS Slave Receiver Timing

4 Package and Reliability

The XMC1400 is a member of the XMC1000 Family of microcontrollers. It is also compatible to a certain extent with members of similar families or subfamilies.

Each package is optimized for the device it houses. Therefore, there may be slight differences between packages of the same pin-count but for different device types. In particular, the size of the exposed die pad may vary.

If different device types are considered or planned for an application, it must be ensured that the board layout fits all packages under consideration.

4.1 Package Parameters

Table 37 provides the thermal characteristics of the packages used in XMC1400.

Table 37 Thermal Characteristics of the Packages

| Parameter | Symbol | Limit Values | | Unit | Package Types |
|-------------------------------------|--------------------|--------------|-----------|------|-----------------------------|
| | | Min. | Max. | | |
| Exposed Die Pad Dimensions | Ex × Ey CC | - | 3.7 × 3.7 | mm | PG-VQFN-40-17 |
| | | - | 4.2 × 4.2 | mm | PG-VQFN-48-73 |
| | | - | 4.6 × 4.6 | mm | PG-VQFN-64-6 |
| Thermal resistance Junction-Ambient | $R_{\Theta JA}$ CC | - | 86.0 | K/W | PG-TSSOP-38-9 ¹⁾ |
| | | - | 45.3 | K/W | PG-VQFN-40-17 ¹⁾ |
| | | - | 44.9 | K/W | PG-VQFN-48-73 ¹⁾ |
| | | - | 66.7 | K/W | PG-LQFP-64-26 ¹⁾ |
| | | - | 44.7 | K/W | PG-VQFN-64-6 ¹⁾ |

1) Device mounted on a 4-layer JEDEC board (JESD 51-5); exposed pad soldered.

Note: For electrical reasons, it is required to connect the exposed pad to the board ground V_{SSP} , independent of EMC and thermal requirements.

4.1.1 Thermal Considerations

When operating the XMC1400 in a system, the total heat generated in the chip must be dissipated to the ambient environment to prevent overheating and the resulting thermal damage.

The maximum heat that can be dissipated depends on the package and its integration into the target board. The “Thermal resistance $R_{\Theta JA}$ ” quantifies these parameters. The power dissipation must be limited so that the average junction temperature does not exceed 115 °C.

Package and Reliability

The difference between junction temperature and ambient temperature is determined by

$$\Delta T = (P_{\text{INT}} + P_{\text{IOSTAT}} + P_{\text{IODYN}}) \times R_{\Theta\text{JA}}$$

The internal power consumption is defined as

$$P_{\text{INT}} = V_{\text{DDP}} \times I_{\text{DDP}} \text{ (switching current and leakage current).}$$

The static external power consumption caused by the output drivers is defined as

$$P_{\text{IOSTAT}} = \Sigma((V_{\text{DDP}} - V_{\text{OH}}) \times I_{\text{OH}}) + \Sigma(V_{\text{OL}} \times I_{\text{OL}})$$

The dynamic external power consumption caused by the output drivers (P_{IODYN}) depends on the capacitive load connected to the respective pins and their switching frequencies.

If the total power dissipation for a given system configuration exceeds the defined limit, countermeasures must be taken to ensure proper system operation:

- Reduce V_{DDP} , if possible in the system
- Reduce the system frequency
- Reduce the number of output pins
- Reduce the load on active output drivers

4.2 Package Outlines

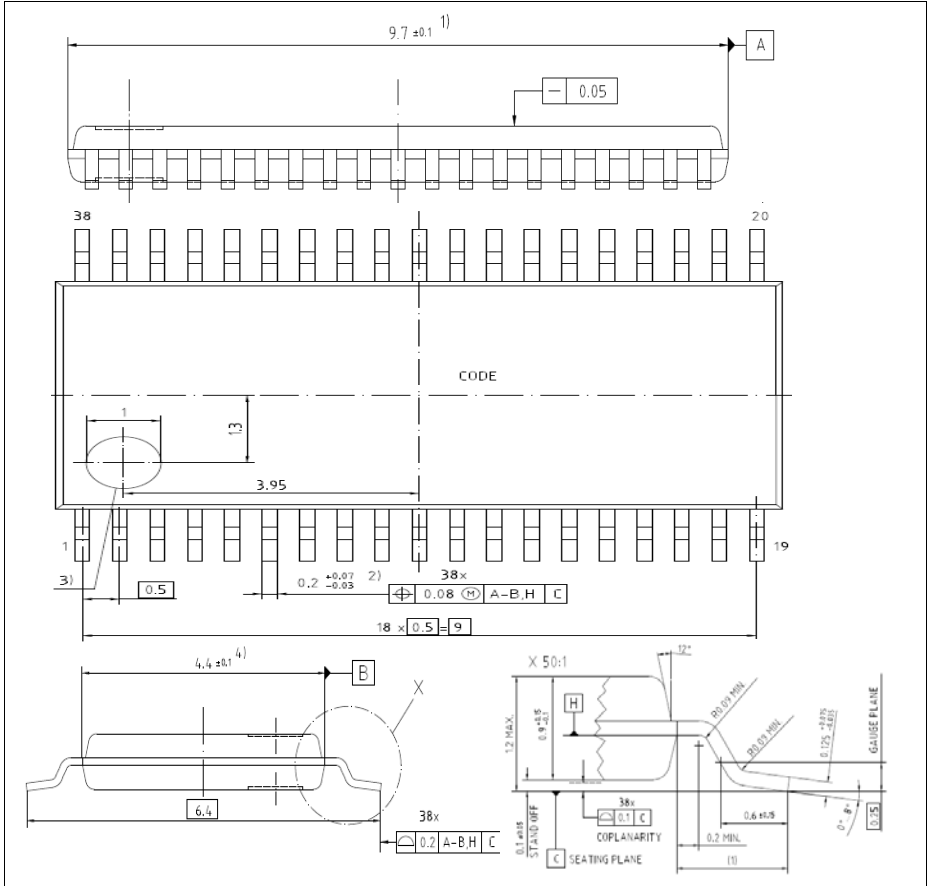

Figure 29 PG-TSSOP-38-9

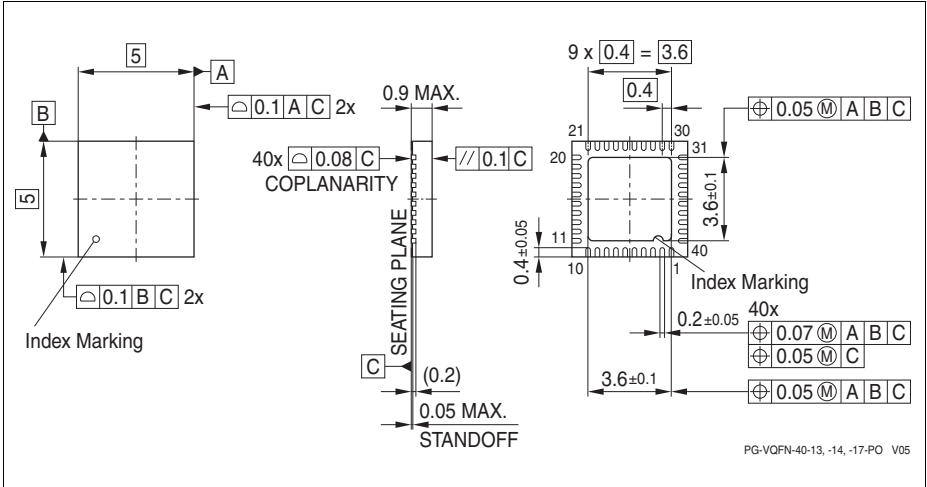

Figure 30 PG-VQFN-40-17

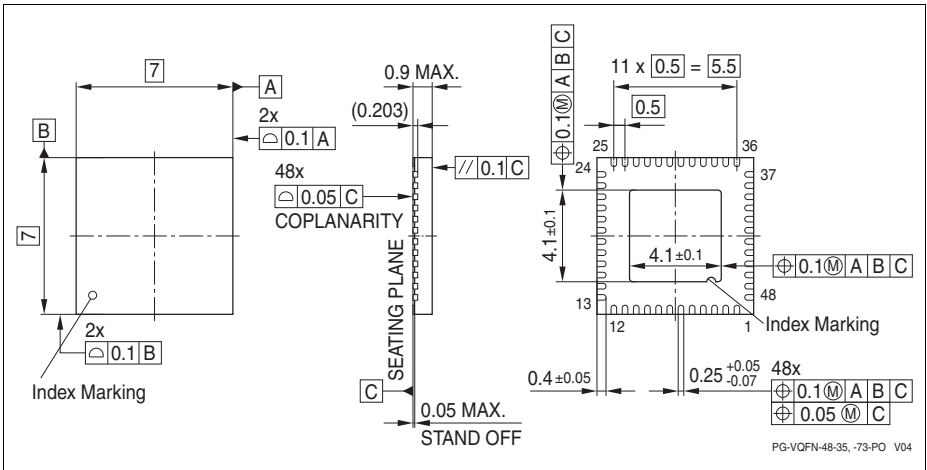

Figure 31 PG-VQFN-48-73

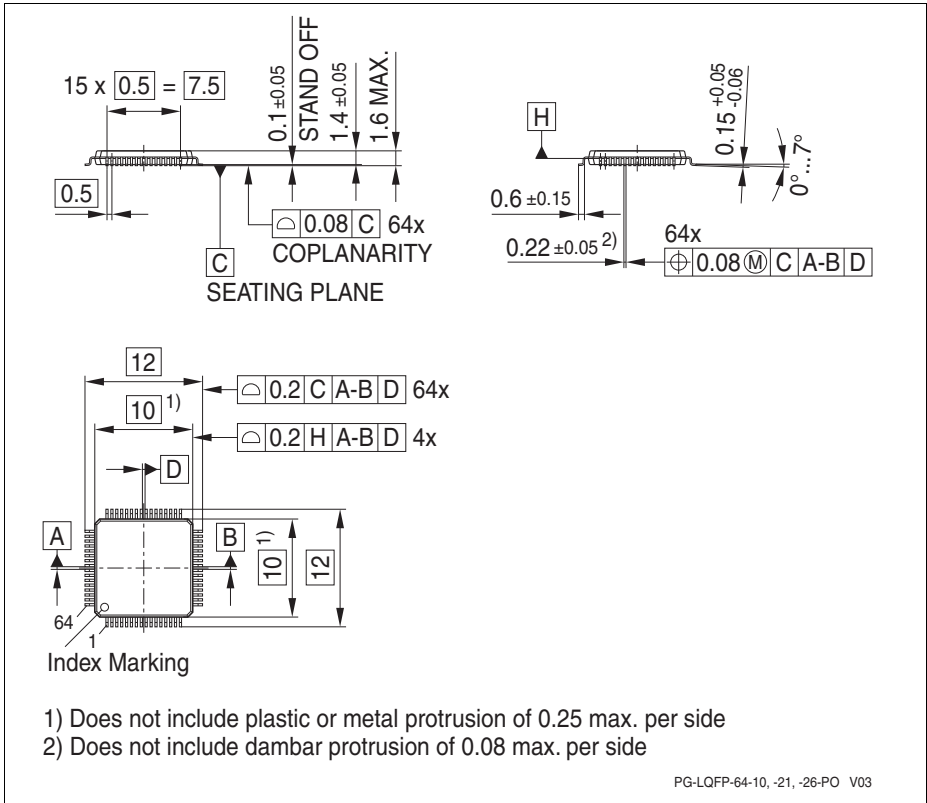

Figure 32 PG-LQFP-64-26

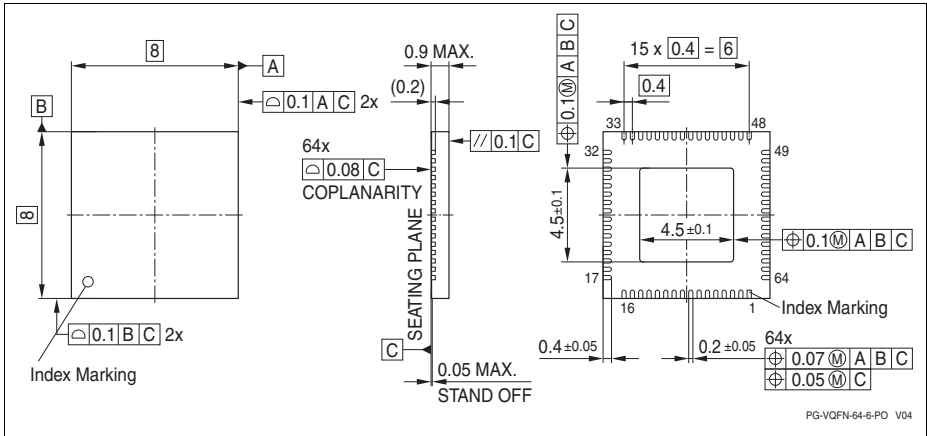

Figure 33 PG-VQFN-64-6

All dimensions in mm.

5 Quality Declaration

Table 38 shows the characteristics of the quality parameters in the XMC1400.

Table 38 Quality Parameters

| Parameter | Symbol | Limit Values | | Unit | Notes |
|---|-----------------|--------------|------|------|---------------------------------------|
| | | Min. | Max. | | |
| ESD susceptibility according to Human Body Model (HBM) | V_{HBM} SR | - | 2000 | V | Conforming to EIA/JESD22-A114-B |
| ESD susceptibility according to Charged Device Model (CDM) pins | V_{CDM} SR | - | 500 | V | Conforming to JESD22-C101-C |
| Moisture sensitivity level | MSL CC | - | 3 | - | JEDEC J-STD-020D |
| Soldering temperature | T_{SDR} SR | - | 260 | °C | Profile according to JEDEC J-STD-020D |

www.infineon.com

Published by Infineon Technologies AG