

REVISIONS				
P	LTN	DESCRIPTION	DATE	APVD
A		FROMAL RELEASED	14JAN2020	IT SH

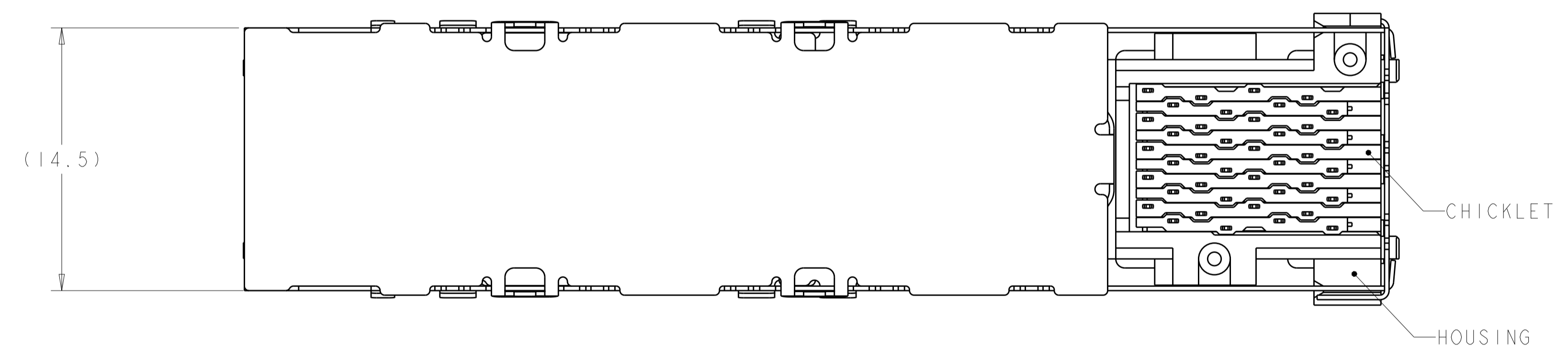

- 1 MATERIALS:
 CAGE ASSEMBLY- NICKEL SILVER ALLOY PER ASTM B 122.
 HOUSING- BLACK LCP, UL 94V-0 RATED.
 CHICKLET- BLACK LCP, UL 94V-0 RATED.
 CONTACT- COPPER ALLOY.
- 2 DATUM AND BASIC DIMENSIONS ESTABLISHED BY CUSTOMER.
- 3. MINIMUM PCB THICKNESS OF 1.5.
- 4 CONTACT FINISH- CONFORMS TO THE REQUIREMENTS OF TYCO ELECTRONICS PRODUCT SPECIFICATION 108-2331, BASED ON EIA/ECA-364-1000.01A, (CONTROLLED ENVIRONMENT APPLICATIONS) ON MATING INTERFACE, TIN ON NEEDLE EYE.
- 5 FOR HOLE SIZE AND PLATINGS, SEE APPLICATION SPEC 114-13219.
- 6 THE ENTIRE AREA OF THE CONNECTOR FOOTPRINT, INDICATED BY THE DASHED LINE, TO BE CONSIDERED THE KEEPOUT AREA FOR COMPONENTS AND SIGNAL TRACES, TOP SIDE ONLY. TOP SIDE TRACES ALLOWED WITHIN CONNECTOR HOLE PATTERN.

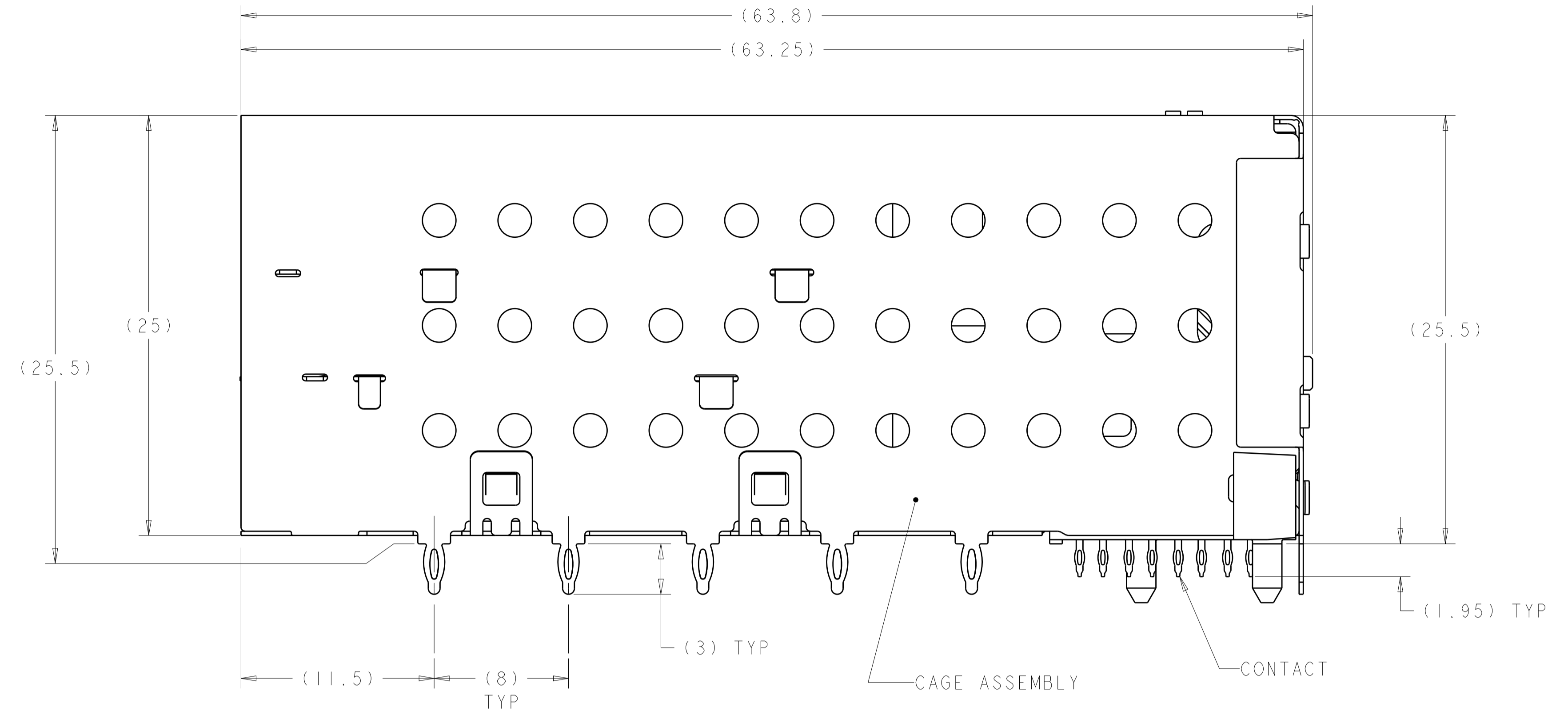
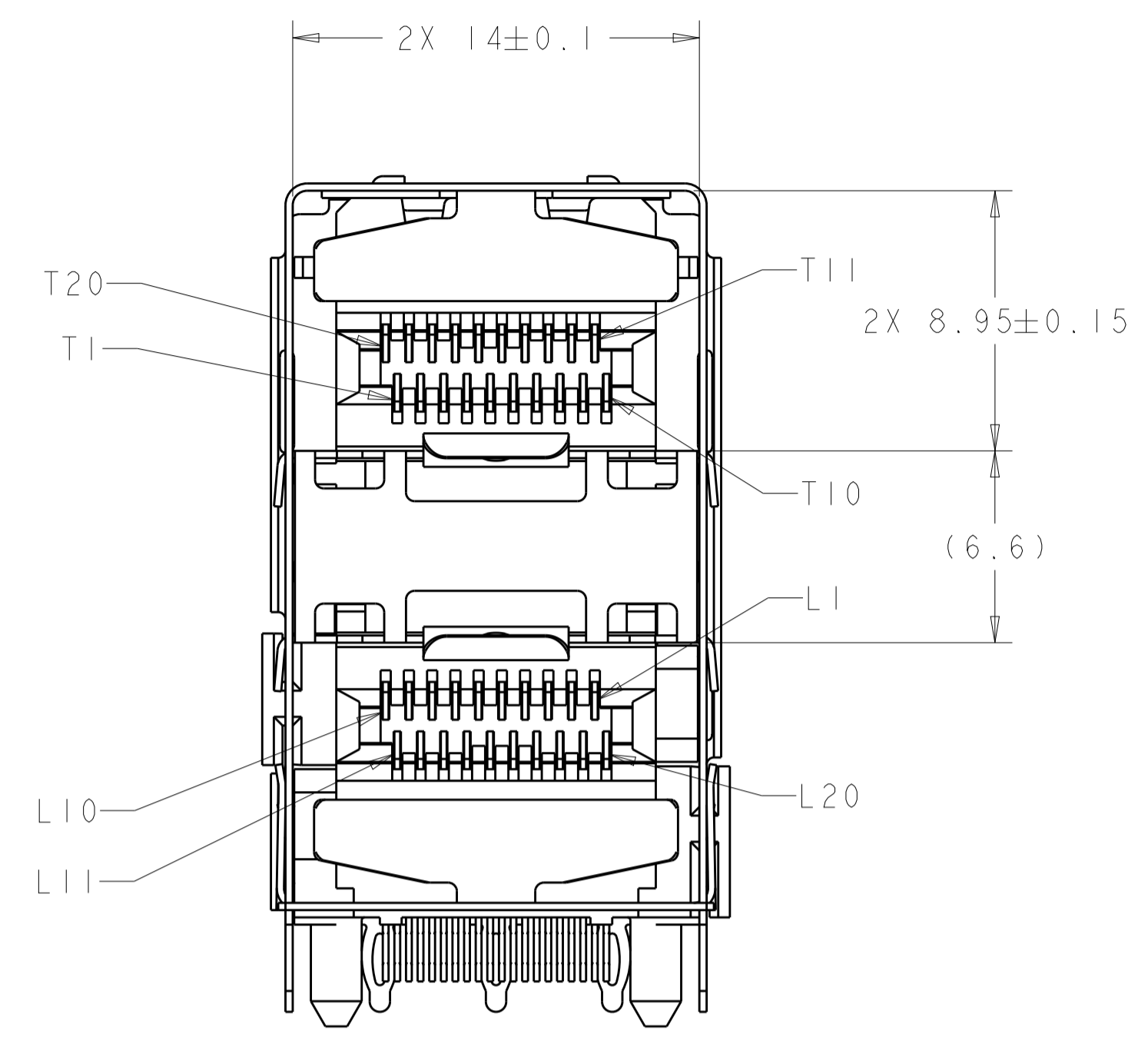
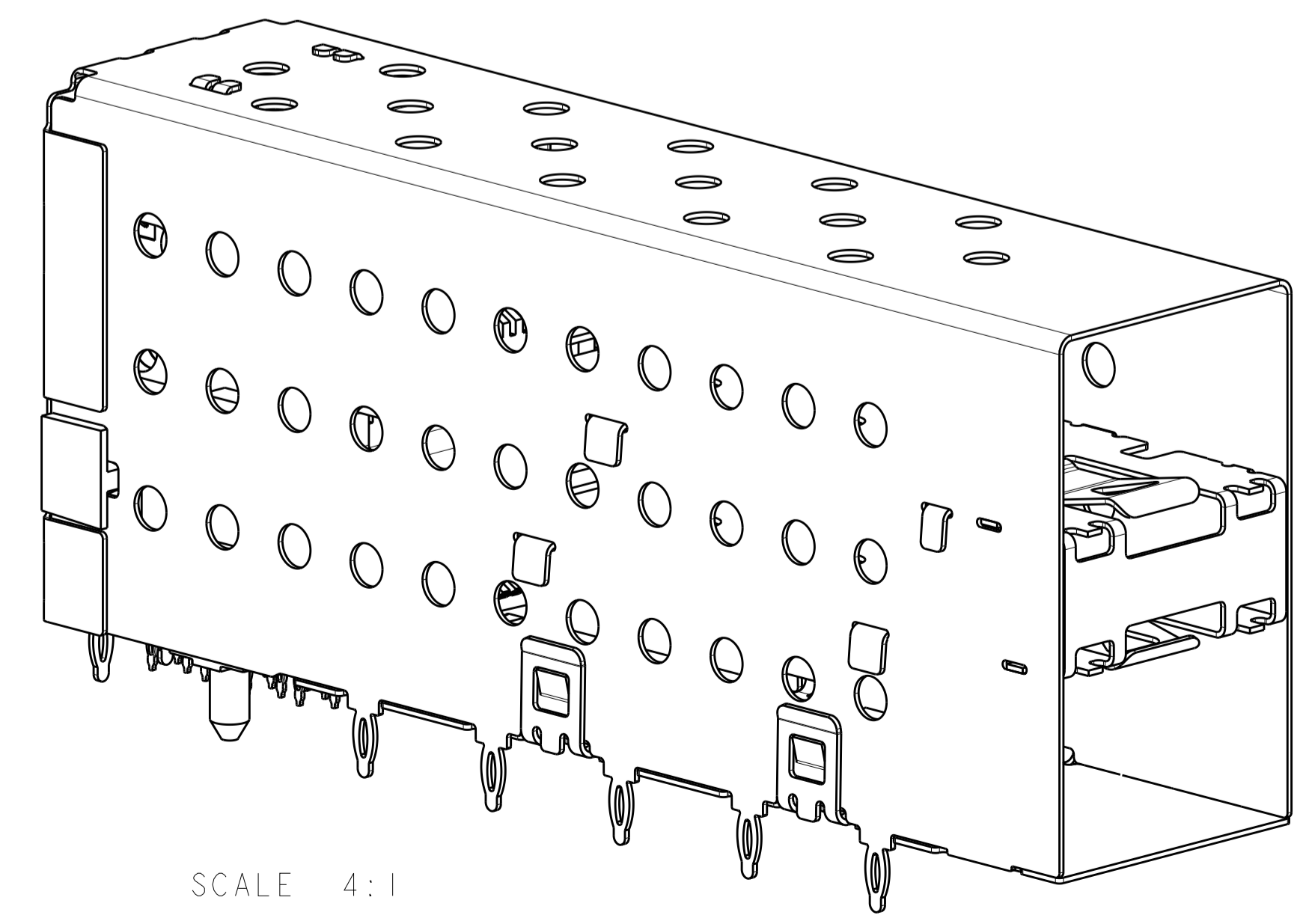

SCALE 4:1

2149102-1
 PART NUMBER

THIS DRAWING IS A CONTROLLED DOCUMENT.		DWN B. MATTHEWS 07AUG2013	TE Connectivity
DIMENSIONS: mm		CHK P. RECCE 07AUG2013	
TOLERANCES UNLESS OTHERWISE SPECIFIED:		APVD P. RECCE 07AUG2013	NAME
0 PLC ±0.10	1 PLC ±0.10	PRODUCT SPEC	CAGE AND PT CONNECTOR ASSEMBLY,
2 PLC ±0.10	3 PLC ±0.10	APPLICATION SPEC	PRESS FIT, 2X1,
4 PLC ±0.10	ANGLES ±°	114-13219	STACKED SFP+
MATERIAL TBD	FINISH	SIZE CAGE CODE DRAWING NO	RESTRICTED TO
		WEIGHT	A100779C=2149102
		CUSTOMER DRAWING	SCALE 5:1 SHEET 1 OF 3 REV A

REVISIONS				
P.	LTR.	DESCRIPTION	DATE	APPD.
-	-	SEE SHEET 1	-	-

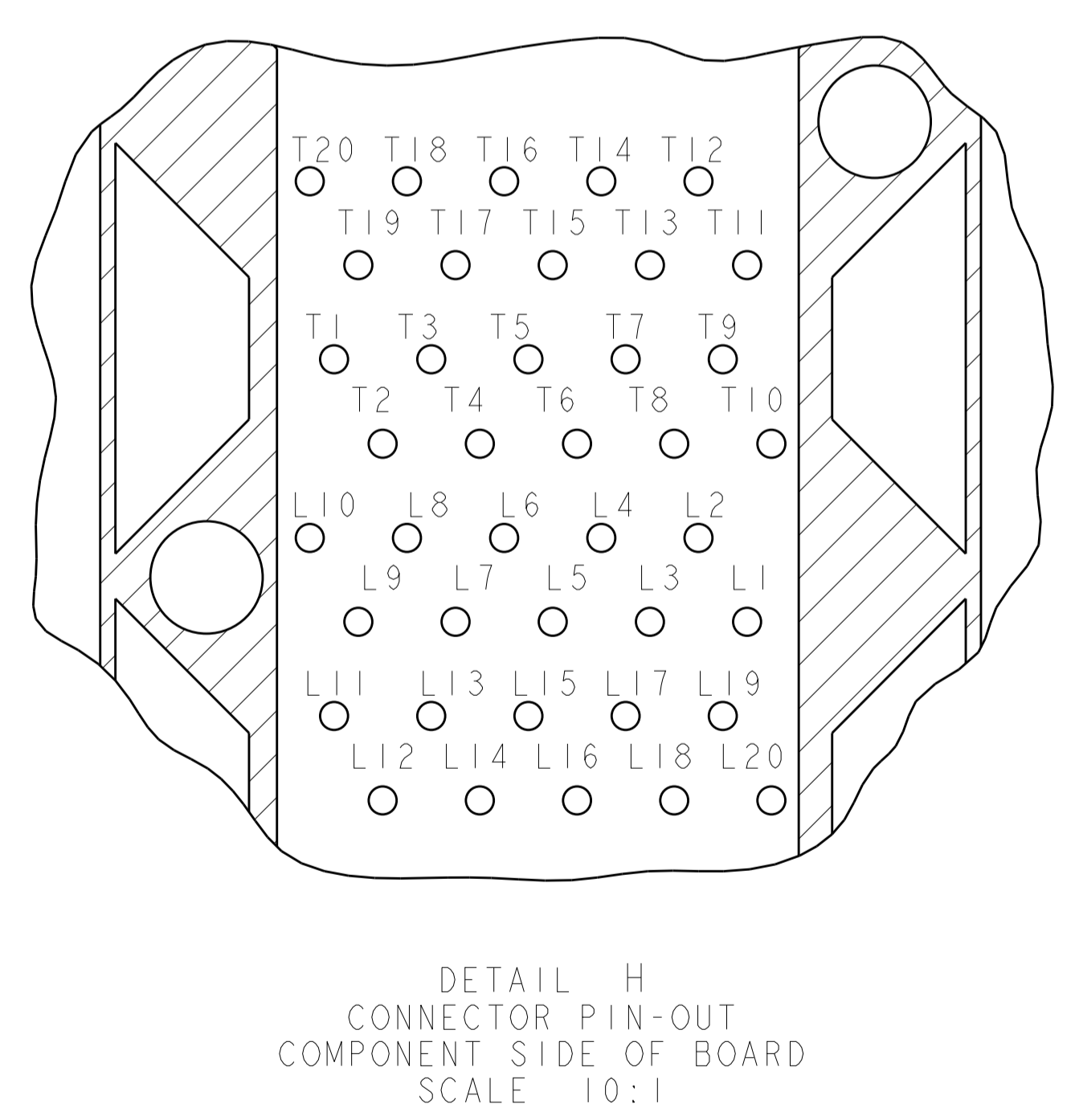
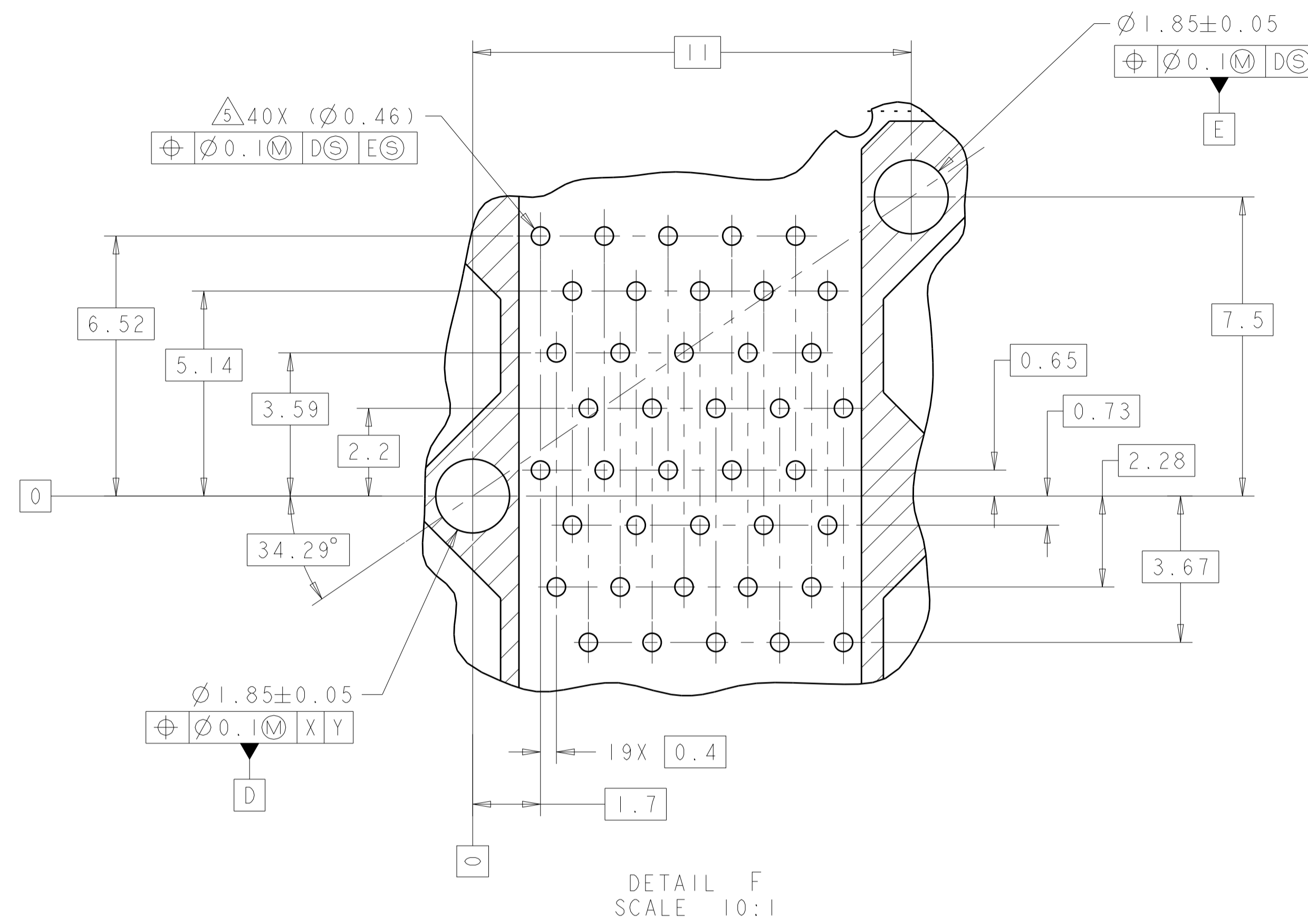
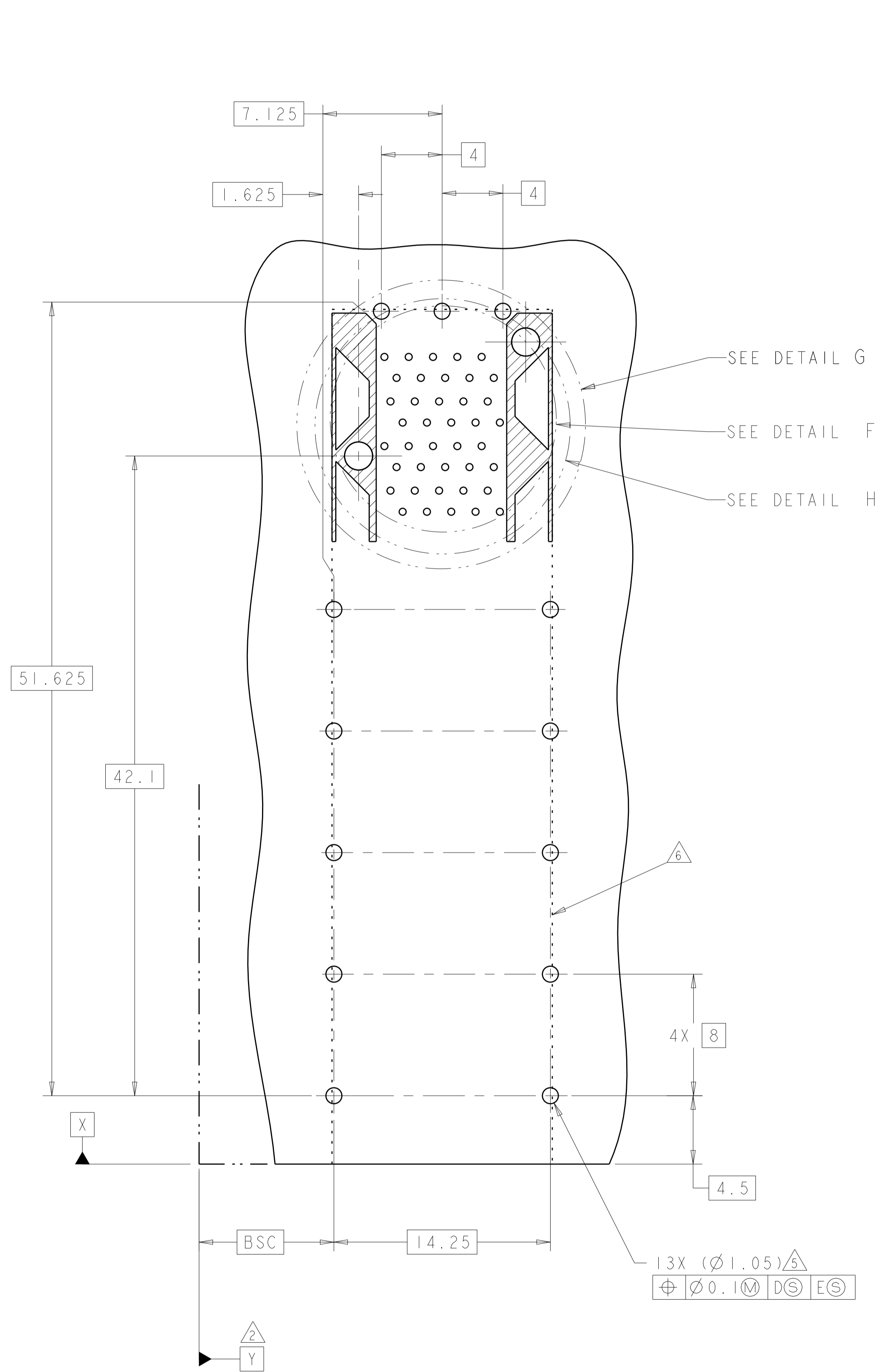

THIS DRAWING IS A CONTROLLED DOCUMENT.		OWN B. MATTHEWS 07AUG2013	TE Connectivity
DIMENSIONS: mm		CHK P. RECCE 07AUG2013	
TOLERANCES UNLESS OTHERWISE SPECIFIED:		APPD P. RECCE 07AUG2013	
0 PLC ±0.10 1 PLC ±0.10 2 PLC ±0.10 3 PLC ±0.10 4 PLC ±0.10 ANGLES ±°		NAME CAGE AND PT CONNECTOR ASSEMBLY, PRESS FIT, 2X1, STACKED SFP+ PRODUCT SPEC 108-2331 APPLICATION SPEC 114-13219 WEIGHT - CUSTOMER DRAWING	
MATERIAL TBD	FINISH -	SIZE A100779C=2149102	RESTRICTED TO
SCALE 5:1 SHEET 2 OF 3 REV A			

REVISIONS				
P.	LTN.	DESCRIPTION	DATE	APVD.
-	-	SEE SHEET 1	-	-

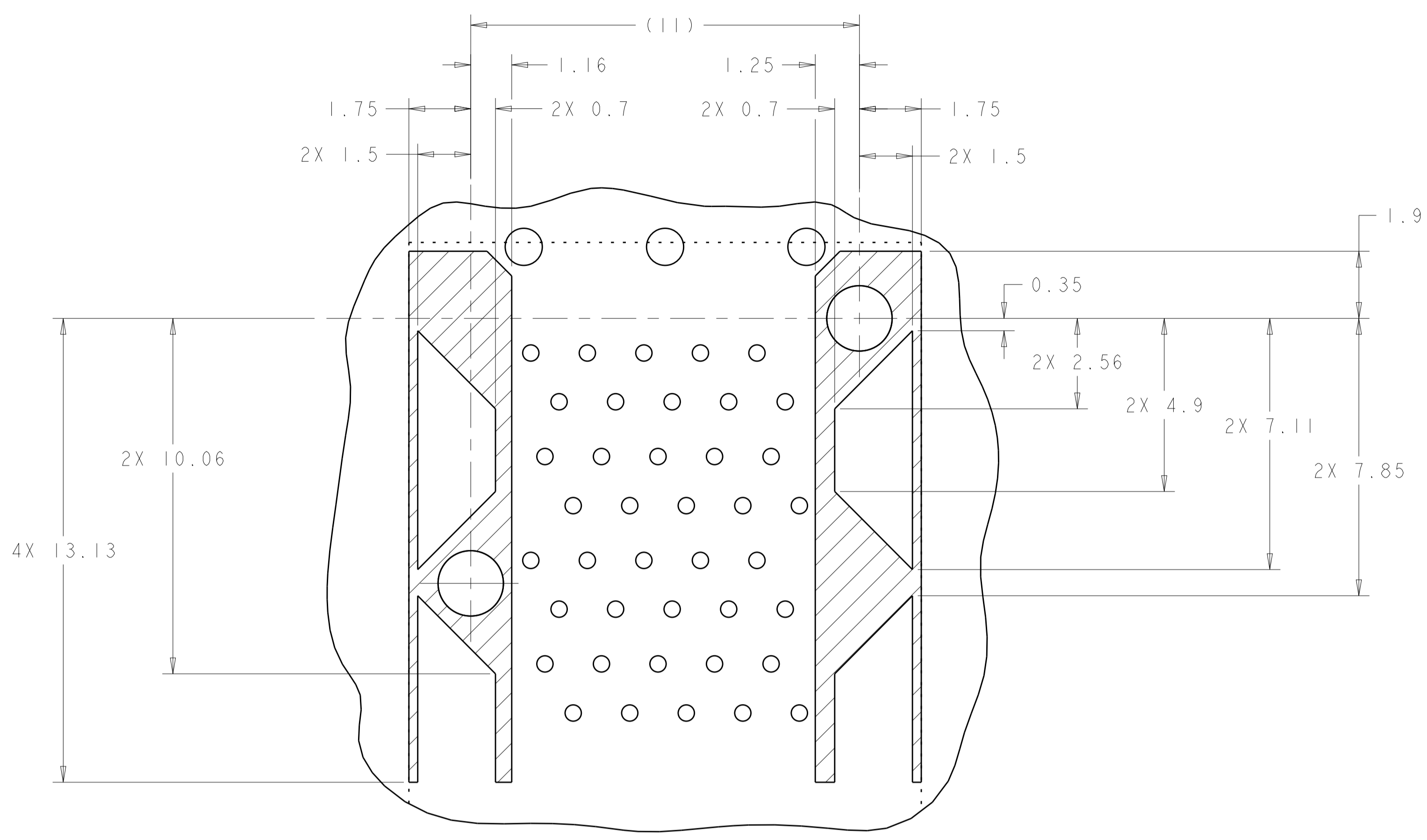

DETAIL G
 CONNECTOR HOUSING
 KEEPOUT ZONE
 SCALE 10:1

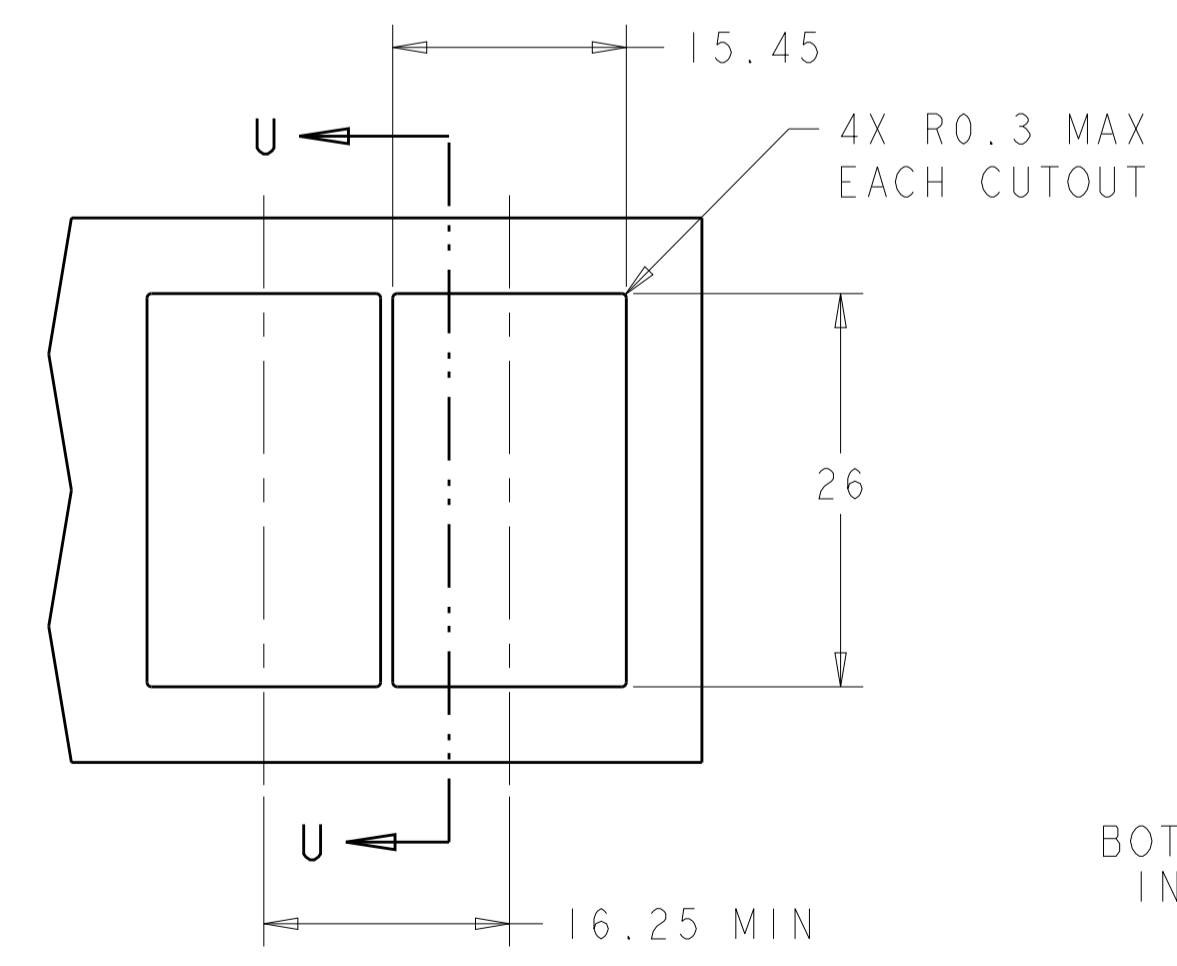

RECOMMENDED PANEL CUTOUT
 AND PC BOARD, PANEL POSITION
 SCALE 2:1

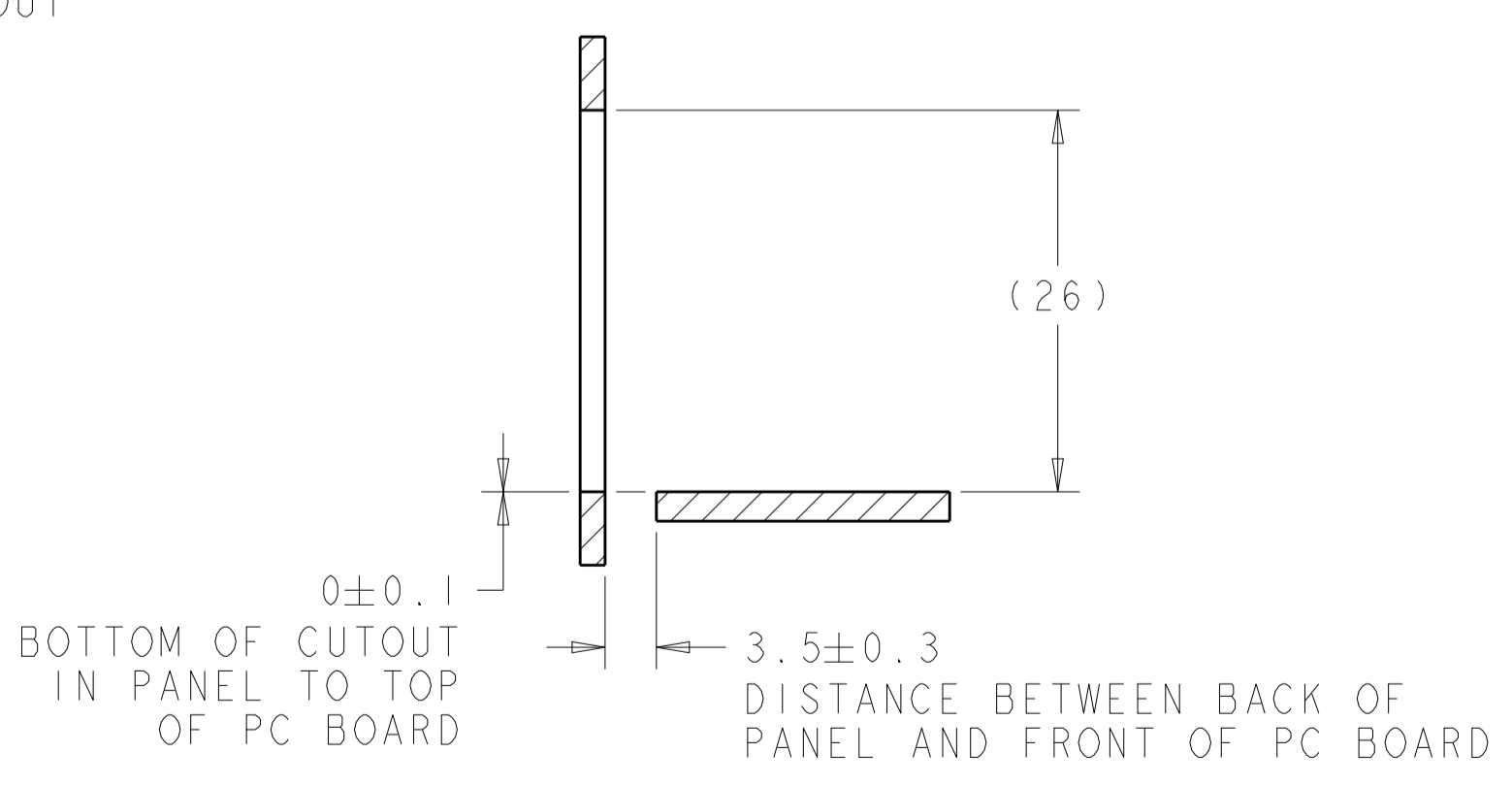

SECTION U-U

THIS DRAWING IS A CONTROLLED DOCUMENT.		DWN B. MATTHEWS 07AUG2013 CHK P. RECCE 07AUG2013 APVD P. RECCE 07AUG2013	STE TE Connectivity	
DIMENSIONS: mm TOLERANCES UNLESS OTHERWISE SPECIFIED: 0 PLC ±0.10 1 PLC ±0.10 2 PLC ±0.10 3 PLC ±0.10 4 PLC ±0.10 ANGLES ±°		PRODUCT SPEC 108-2331 APPLICATION SPEC 114-13219 WEIGHT - CUSTOMER DRAWING	NAME CAGE AND PT CONNECTOR ASSEMBLY, PRESS FIT, 2X1, STACKED SFP+ SIZE CAGE CODE DRAWING NO. RESTRICTED TO A100779C=2149102 -	
MATERIAL TBD		SCALE 5:1		SHEET 3 OF 3 REV A