

THIS DRAWING IS A CONTROLLED DOCUMENT.

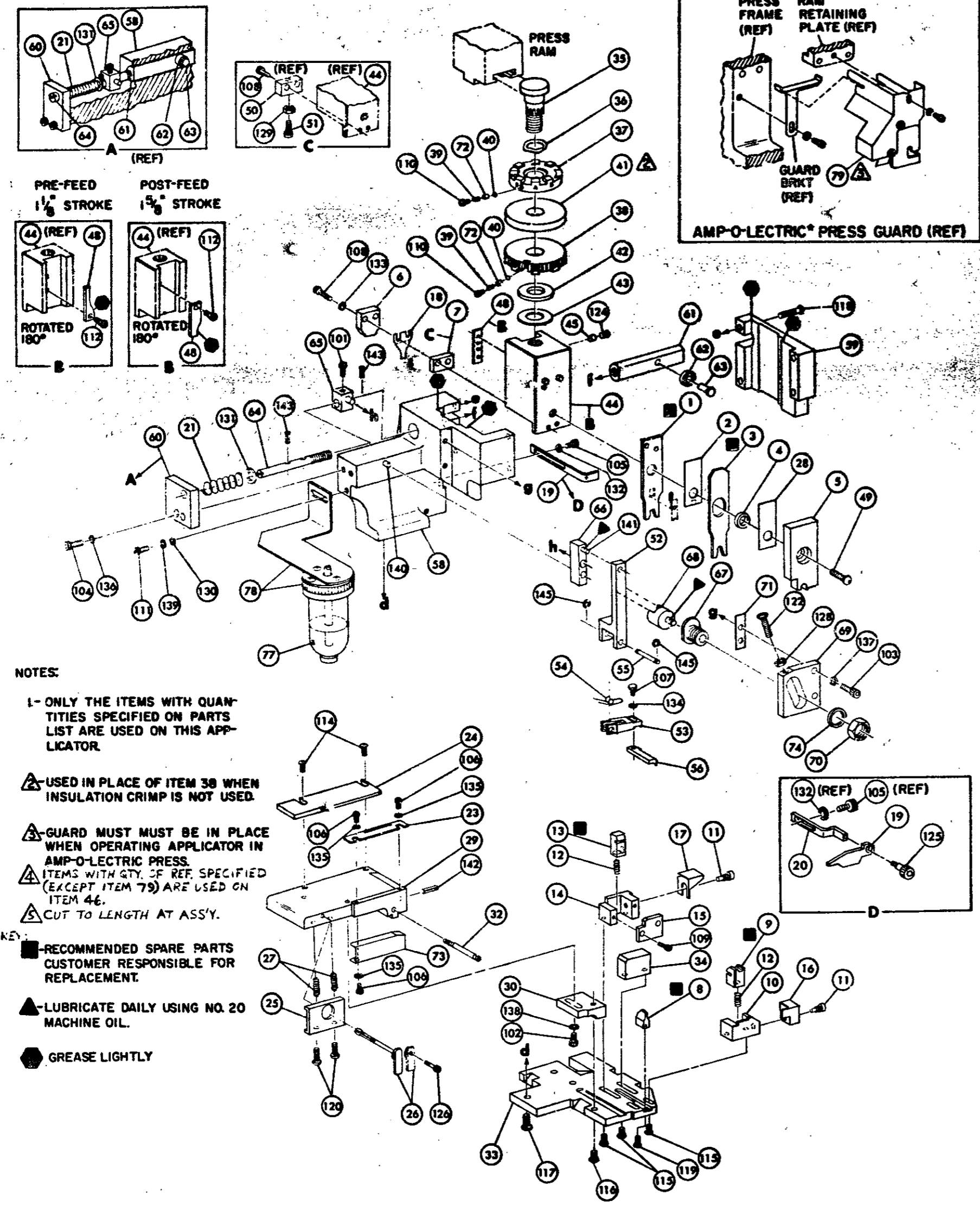

NOTES:

- 1- ONLY THE ITEMS WITH QUANTITIES SPECIFIED ON PARTS LIST ARE USED ON THIS APPLICATOR.
- ▲ USED IN PLACE OF ITEM 30 WHEN INSULATION CRIMP IS NOT USED.
- ▲ GUARD MUST BE IN PLACE WHEN OPERATING APPLICATOR IN AMP-O-LECTRIC PRESS.
- ▲ ITEMS WITH QTY. OF REF SPECIFIED (EXCEPT ITEM 79) ARE USED ON ITEM 46.
- ▲ CUT TO LENGTH AT ASSY.
- RECOMMENDED SPARE PARTS CUSTOMER RESPONSIBLE FOR REPLACEMENT.
- ▲ LUBRICATE DAILY USING NO. 20 MACHINE OIL.
- GREASE LIGHTLY

REF	QTY	PART NO	DESCRIPTION	ITEM NO	REF	QTY	PART NO	DESCRIPTION	ITEM NO
REF		21045-3	RING, RETAINING 'C' (.187 DIA) FEED FINGER PIN	148	REF	454220-1	CAP, HOUSING	30	
REF		5-21028-1	PIN, SLOT SPR (.125 DIA X .50) ADJ ROD	143	REF	454458-1	HOUSING	30	
REF	1	4-21030-0	PIN, SLOT SPR (.093 DIA X .75) STR G PLATE	142		690542-2	PAWL, FEED	30	
REF	1	1-21030-1	PIN, DOWEL (.187 DIA X .50) LEVER	141	REF	240624-1	PIN, FEED FINGER	30	
REF	1	1-21030-6	PIN, DOWEL (.107 DIA X 1.25) HOUSING	140	REF	601499-1	SPRING, FEED FINGER	30	
REF	1	21024-5	WASHER, LOCK (NO 10) LUB ASSY	139	REF	600641-1	FINGER, FEED	30	
REF	1	21024-5	WASHER, LOCK (NO 10) STRIP GUIDE ADJ BLOCK	138	REF	690679-1	LEVER, TERMINAL FEED ARM	30	
REF	1	21024-5	WASHER, LOCK (NO 10) ADJ PLATE	137		811242-2	BUSH, HOLD-DOWN	31	
REF	1	21024-5	WASHER, LOCK (NO 10) FEED GUIDE ROD	136		690753-1	SPACER, TONNER	30	
REF	1	21057-2	WASHER, LOCK (NO 4) FRONT STRIP GUIDE	135		7-21002-9	BOLT, CRIMPER	40	
REF	1	21024-4	WASHER, LOCK (NO 8) FEED FINGER	134		690402-5	CAM PRE-FEED 1/3 STROKE	40	
REF	1	21024-4	WASHER, LOCK (NO 8) DEPRESSOR	133				47	
REF	1	21024-4	WASHER, LOCK (NO 8) STRIPPER	132		459456-1	APPLICATOR, BASIC (SUB ASSY)	40	
REF	1	21899-4	WASHER, LOCK (5/16 DIA) SCREW ADJ	131		690191-1	PLUG, NYLON	40	
REF	1	21899-2	WASHER, FLAT (NO 10) LUB ASSY	130		455673-1	RAM	40	
REF	1	21068-5	NUT, HEX MACH (6-32) HOLD-DOWN	129		690125-1	WASHER, LAMINATED	40	
REF	1	21068-5	NUT, HEX MACH (6-32) FEED ADJ	128		690124-1	WASHER, RAIN	40	
				127		690223-1	DISC, SPACER	41	
				126		23241-6	BALL, STEEL	40	
				125		690170-1	SPRING, COMPRESSION	30	
				124			DISC, INSULATION	30	
REF	1	3-21064-2	SCR, RD HD MACH (6-32 X 1.50) FEED ADJ	123		690692-7	DISC, WIRE	37	
				122		22480-5	WASHER, SPRING	30	
				121		690212-1	POST, RAM	37	
				120		692776-1	SUPPORT, TERMINAL	30	
				119	REF	455675-1	PLATE, BASE	30	
				118		690432-3	SCREW, ADJUSTMENT	30	
				117				31	
REF	1	3-21002-0	SCR, BHC (10-32 X .86) DRAG	120		455689-1	BLOCK, STRIP GUIDE ADJ	30	
REF	1	27735-8	SCR, BUT HD SKT CAP (8-32 X .38) (LOC-WEL) ANVIL	119		1-455671-6	PLATE, STRIP GUIDE	29	
REF	1	3-21002-9	SCR, BUT HD SKT CAP (10-32 X .75) CAP	118		1-455888-0	SPACER, FRONT SHEAR DEPRESSOR	28	
REF	1	1-20773-9	SCR, BUT HD SKT CAP (1/4-20 X .75) HOUSING	117		1-22284-0	SPRING, DRAG	27	
REF	1	2-21003-7	SCR, BUT HD SKT CAP (10-32 X .50) SG ADJ BLOCK	116	REF	455689-1	BLOCK, STRIP GUIDE ADJ	30	
REF	1	2-21002-2	SCR, BUT HD SKT CAP (8-32 X .50) SHEAR	115		1-455671-6	PLATE, STRIP GUIDE	29	
REF	1	2-21002-2	SCR, BUT HD SKT CAP (8-32 X .50) R STRIP GUIDE	114		1-455888-0	SPACER, FRONT SHEAR DEPRESSOR	28	
				113		1-22284-0	SPRING, DRAG	27	
				112		690546-1	LEVER, DRAG RELEASE	26	
				111		240732-1	DRAG, STOCK	25	
				110		690504-6	GUIDE STRIP (REAR)	24	
				109		690438-1	GUIDE, STRIP (FRONT)	23	
				108				22	
				107	REF	4-22284-9	SPRING, FEED RETURN	25	
				106		458949-1	ARM, STRIPPER	25	
				105		458950-1	STRIPPER	19	
				104			HOLDER, TERMINAL	18	
REF	1	3-21000-7	SCR, SKT HD CAP (10-32 X .75) FEED ROD GUIDE	104			GUARD, CHIP (REAR)	17	
REF	1	3-21000-6	SCR, SKT HD CAP (10-32 X .62) FEED ADJ BLOCK	103			GUARD, CHIP (FRONT)	16	
				102		691667-1	PLATE, SHEAR (REAR)	15	
REF	1	3-21000-4	SCR, SKT HD CAP (10-32 X .38) SG ADJ BLOCK	101			HOLDER, SHEAR (REAR)	14	
REF	1	455749-1	GUARD	79			SHEAR, FLOAT (REAR)	13	
				78			SPRING, SHEAR	12	
				77		5-22280-0	STOP, SHEAR	11	
				76		690461-1	HOLDER, SHEAR (FRONT)	10	
				75		690459-1	SHEAR, FLOAT (FRONT)	9	
				74		454276-1	ANVIL	8	
				73		9-690512-1	SPACER, DEPRESSOR (REAR)	7	
				72			DEPRESSOR, SHEAR (REAR)	6	
REF	1	458109-1	WASHER, SPECIAL	74			DEPRESSOR, SHEAR (FRONT)	5	
				73			SPACER, TUBULAR, INS CRIMPER	4	
				72			CRIMPER, INSULATION	3	
REF	1	454877-3	PLATE, STRIP GUIDE COVER	72			SPACER, CRIMPER	2	
				71			CRIMPER, WIRE	1	
				70		1-455889-4			
				69					
				68					
				67					
				66					
				65					
				64					
				63					
				62					
				61					
				60					
REF	1	454178-1	GUIDE, FEED ROD	60					

REMARKS	NO	REV
APPL USED ON MACHINE PART NO	MACH SERIAL NO	DISTRIBUTION
CUSTOMER NAME	APPL SERIAL NO	ORIGINAL
ADDRESS	PURCHASE ORDER	CUSTOMER COPY
CITY	ENG APP	FIELD ENG COPY

CRIMPING DATA				APPLICATOR WILL APPLY
PAD LTR	CRIMP HEIGHT	WIRE SIZE	WIRE STRIP LENGTH	62505
A	.053	18		
B	NOT USED			
C	.049	20		
D	.047	22		
CRIMP WIRE	SIZE	TYPE	FEED	APPL INST
WIRE	.090	F	405	A1 8040
INSUL				
WIRE RANGE	22-18	INSULATION RANGE	PRESS NO	565435-5
REMARKS	AMP-O-LECTRIC PRE-FEED			
	I.D. PLATE (REF: 461264-1)			

REV	DATE	DESCRIPTION	BY
1	0150-2572-02	NS 16/38	SET UP GAGE 10-1
2	0150-6084-26	EC	458637-1 917
3	0150-6575-56	FB 1/20	DR 2-18 APP 7/14
4	0150-6124-95	TE 5/20	DR 2-18 APP 7/14
5	0150-4470-28	TE 5/20	DR 2-18 APP 7/14
6	0150-4470-28	TE 5/20	DR 2-18 APP 7/14
7	0150-4470-28	TE 5/20	DR 2-18 APP 7/14
8	0150-4470-28	TE 5/20	DR 2-18 APP 7/14
9	0150-4470-28	TE 5/20	DR 2-18 APP 7/14
10	0150-4470-28	TE 5/20	DR 2-18 APP 7/14