

4

3

2

1

THIS DRAWING IS UNPUBLISHED. RELEASED FOR PUBLICATION  
COPYRIGHT BY TYCO ELECTRONICS CORPORATION, ALL RIGHTS RESERVED.

LOC	DIST	REVISIONS					
		P	LTR	DESCRIPTION	DATE	DWN	APVD
DS	-		A1	REVISED (ECR-11-005815)	22.MAR.'11	KT	HG

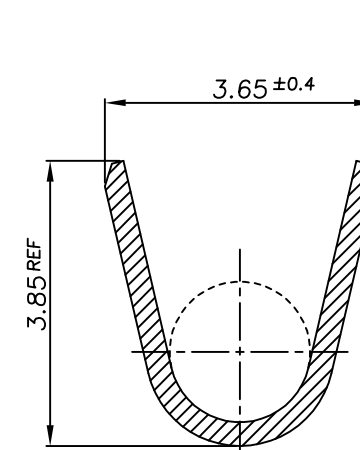
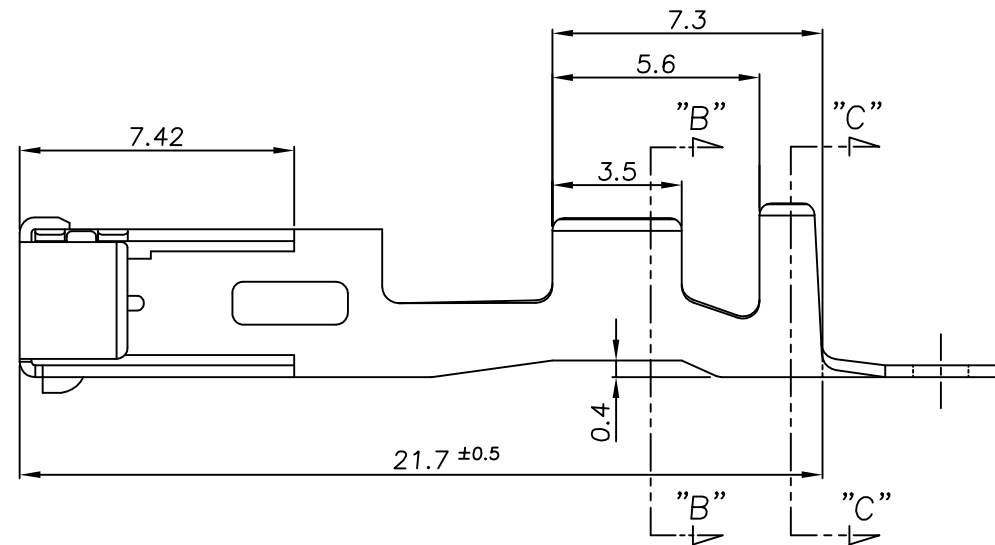
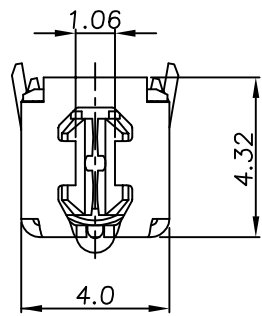
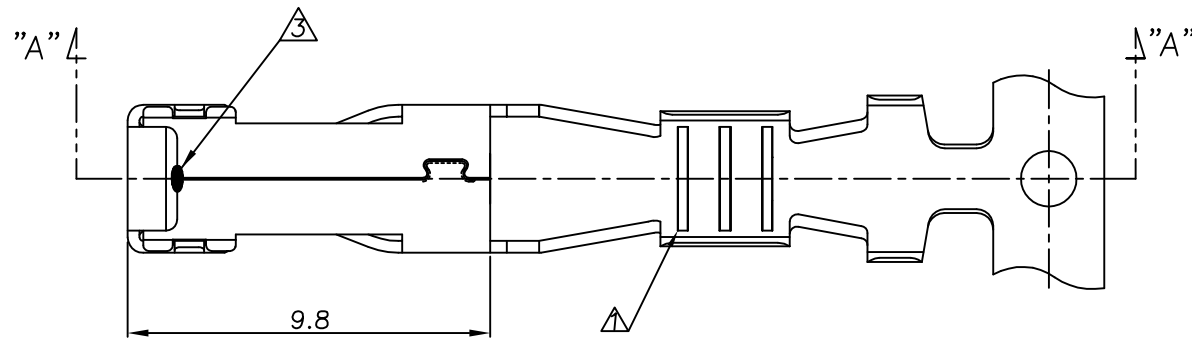

SECTION "B-B"  
Scale 10/1

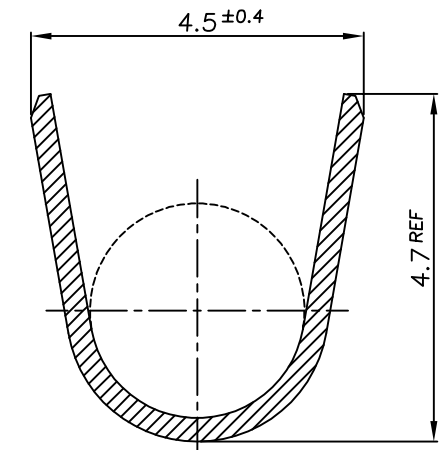

SECTION "C-C"  
Scale 10/1

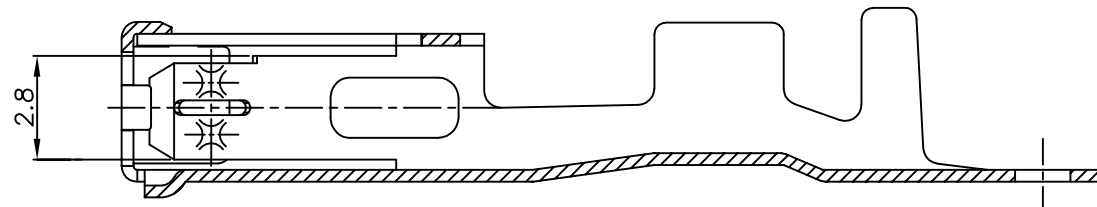
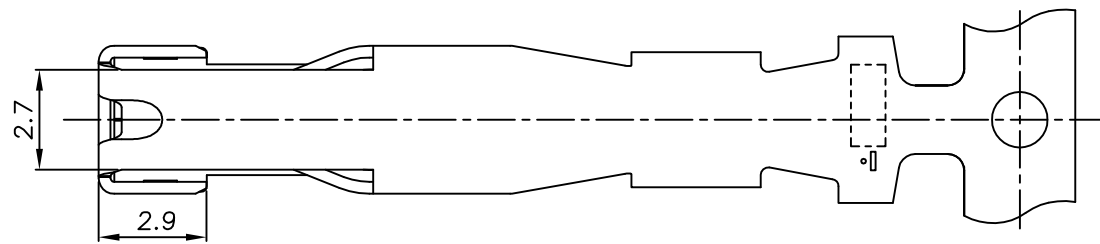

SECTION "A-A"

NOTE;

- ▲ THREE SERRATIONS CENTERED IN WIRE BARREL.
- 2 WIRE SIZE EQUIV 1.25 ~ 2.5SQ.  
APPLICATION SPEC: 114-61033
- ▲ WELDING POINT

THIS DRAWING IS A CONTROLLED DOCUMENT FOR TYCO ELECTRONICS CORPORATION  
IT IS SUBJECT TO CHANGE AND THE CONTROLLING ENGINEERING ORGANIZATION  
SHOULD BE CONTACTED FOR THE LATEST REVISION.

DIMENSIONS: MM	TOLERANCES UNLESS OTHERWISE SPECIFIED: 0 <XX<10 ± 0.25 10<XX<30 ± 0.3 ANGLES ± 3°
MATERIAL SEE TABLE	FINISH SEE TABLE

PRE-TINNED	CuNiSi Alloy 0.32THK.	1743163-1
FINISH	MATERIAL	PART NO
DWN KT JUNG CHK KT LIM	TE Connectivity	
APVD HG CHD		
PRODUCT SPEC	NAME 2.8mm MCP-E NON SEALED RECEP CONTACT (L)	
APPLICATION SPEC 114-61033	SIZE A3	CAGE CODE 00779
WEIGHT	DRAWING NO C-1743163	RESTRICTED TO -
CUSTOMER DRAWING	SCALE 5/1	SHEET 1 OF 1 REV A1