

AMR132x

360°, Ultra-Low Power, Omnipolar Switch Sensor

Description

The AMR132x is an omnipolar magnetic switch integrated with anisotropic magnetoresistance (AMR) magnetic sensor and CMOS circuitry, which is able to detect the change of magnetic field and output high and low voltage signals for high accuracy position detection.

The AMR132x series switch can detect magnetic fields from all directions in the plane, enabling 360° sensing. It provides 100 Hz sampling frequency, 1 μ A power consumption, and a wide range of operating voltages from 1.8 V to 5.5 V. It has excellent thermal stability and immunity to stray field interference.

The AMR132x available in the compact SOT23-3 package.



SOT23-3

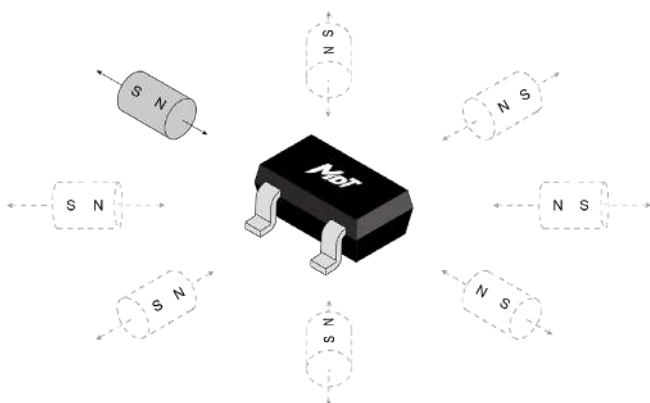

Features and Benefits

- Anisotropic magnetoresistance (AMR) technology
- Low power consumption at 1 μ A
- Fast internal switching frequency at 100 Hz
- Omnipolar operation
- High sensitivity
- Wide range supply voltages: 1.8 V to 5.5V
- CMOS output
- Excellent temperature stability
- High tolerance to external magnetic field interference
- RoHS & REACH compliant

Applications

- Utility meters: water, gas, and heat meters
- Proximity switches
- Speed sensing
- Linear and rotary position sensing
- Wake up switches

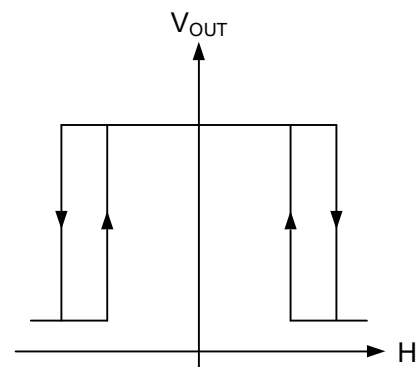

Selection Guide

Part Number	Supply Current	Switching Frequency	Operating Ambient Temperature	Operating Point	Release Point	Package	Packing Form
AMR1320S	1 μ A	30 Hz	-40 °C to 125 °C	\pm 17 Gs	\pm 12 Gs	SOT23-3	Tape & Reel
AMR1321S	3 μ A	100 Hz	-40 °C to 125 °C	\pm 25 Gs	\pm 20 Gs	SOT23-3	Tape & Reel

Note: Please contact MultiDimension Technology local sales for customizing operating and release points.

Catalogue

1. Functional Block Diagram.....	03
2. Switching Characteristics	03
3. Pin Configuration	03
4. Absolute Maximum Ratings	04
5. Electrical Specifications.....	04
6. Magnetic Specifications.....	04
7. Typical Supply Voltage Characteristics.....	05
8. Typical Temperature Characteristics	06
9. Application Information	07
10. Dimensions.....	08

1. Functional Block Diagram

The AMR132x series switches are composed of AMR sensors and signal processing circuits. The AMR sensor detects external magnetic field, generates an analog voltage signal, and outputs a logical switch level after processing by the circuit as shown in Figure 1.

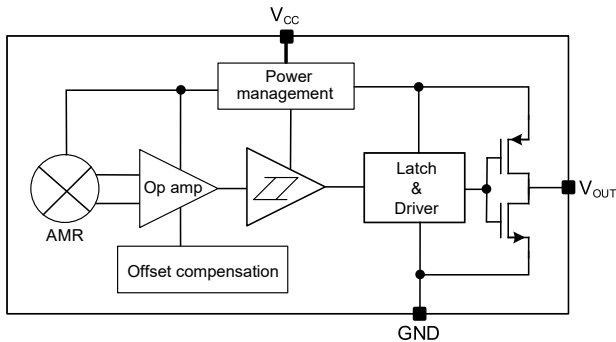

Figure 1. Block diagram

2. Switching Characteristics

Figure 2 shows the sensing direction is parallel to the laser mark surface of the package as shown by the arrows in the X-Y plane.

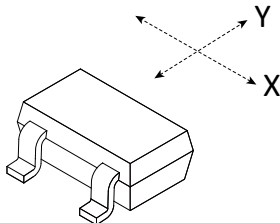

Figure 2. Sensing direction

The output is “High”, when power is on at zero magnetic field. B is the external magnetic field along the sensing direction, B_{OPS} (B_{OPN}) is the operating point, B_{RPS} (B_{RPN}) is the release point, and hysteresis B_H is define as the difference between B_{OPS} and B_{RPS} (B_{OPN} and B_{RPN}).

The sensor outputs a high level, when the magnetic field along the sensing axis exceed the operating point B_{OPS} (B_{OPN}), and the device outputs a low level, when the magnetic field is reduced below the release point B_{RPS} (B_{RPN}) as shown in Figure 3.

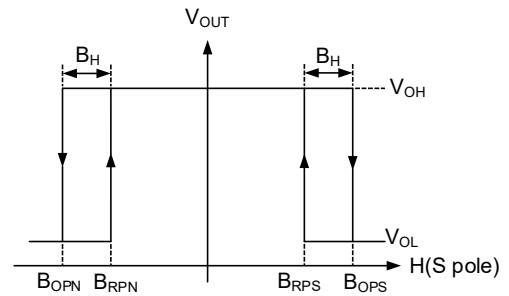

Figure 3. Switching characteristics

3. Pin Configuration

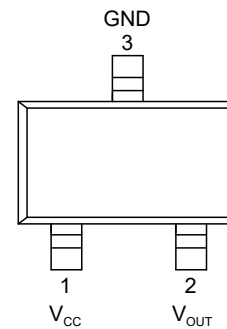

Figure 4. Pin configuration (SOT23-3)

Pin Number	Name	Function
1	V_{CC}	Power supply
2	V_{OUT}	Output
3	GND	Ground

4. Absolute Maximum Ratings

Parameters	Symbol	Min.	Max.	Unit
Supply voltage	V_{CC}	-0.3	7	V
Output current	$I_{SINK}, I_{SOURCE}^{1)}$	-	9	mA
Magnetic flux density	B	-	4000	Gs
ESD performance (HBM)	V_{ESD}	-	4	kV
Operating ambient temperature	T_A	-40	125	°C
Storage ambient temperature	T_{STG}	-50	150	°C

1) I_{SINK} is the current flowing through the pin of switch, when the output is turned on. I_{SOURCE} is the current flowing through the pin of the switch, when the output is turned off.

5. Electrical Specifications

$V_{CC} = 3\text{ V}$, $T_A = 25\text{ °C}$, a 0.1 μF capacitor is connected between V_{CC} and GND unless specified otherwise

Parameter	Symbol	Condition	Min.	Typ.	Max.	Unit	Applicable Part Number
Supply voltage	V_{CC}	Operating	1.8	3.0	5.5	V	All parts
Output high voltage	V_{OH}	RP	$V_{CC} - 0.3$	-	V_{CC}	V	All parts
Output low voltage	V_{OL}	OP	0	-	0.2	V	All parts
Supply current	I_{CC}	OP/RP	-	1.0	-	μA	AMR1320S
			-	3.0	5.0	μA	AMR1321S
Switching frequency	F	-	-	30	-	Hz	AMR1320S
		-	-	100	-	Hz	AMR1321S

6. Magnetic Specifications

$V_{CC} = 3\text{ V}$, $T_A = 25\text{ °C}$, a 0.1 μF capacitor is connected between V_{CC} and GND unless specified otherwise

AMR1320S

Parameter	Symbol	Min.	Typ.	Max.	Unit
Operate point	B_{OPS}	10	17	25	Gs
	B_{OPN}	-25	-17	-10	Gs
Release point	B_{RPS}	8	12	20	Gs
	B_{RPN}	-20	-12	-8	Gs
Hysteresis	B_H	-	5	-	Gs

AMR1321S

Parameter	Symbol	Min.	Typ.	Max.	Unit
Operate point	B_{OPS}	10	25	40	Gs
	B_{OPN}	-40	-25	-10	Gs
Release point	B_{RPS}	8	20	35	Gs
	B_{RPN}	-35	-20	-8	Gs
Hysteresis	B_H	2	5	10	Gs

7. Typical Supply Voltage Characteristics

AMR1320S Supply Voltage Characteristics

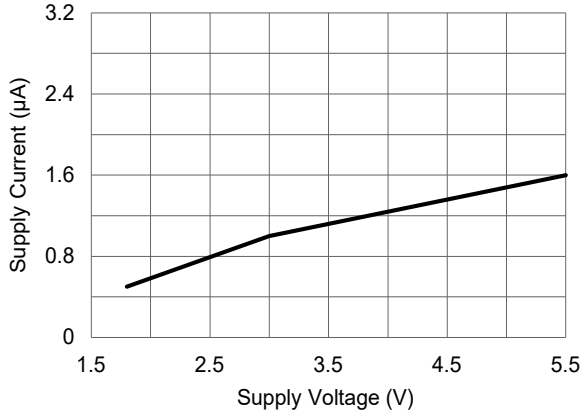

Figure 5. Supply current versus supply voltage ($T_A=25^\circ\text{C}$)

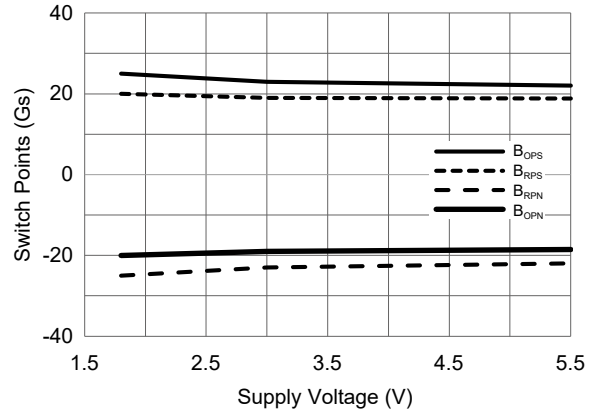

Figure 6. Switch points versus supply voltage ($T_A=25^\circ\text{C}$)

AMR1321S Supply Voltage Characteristics

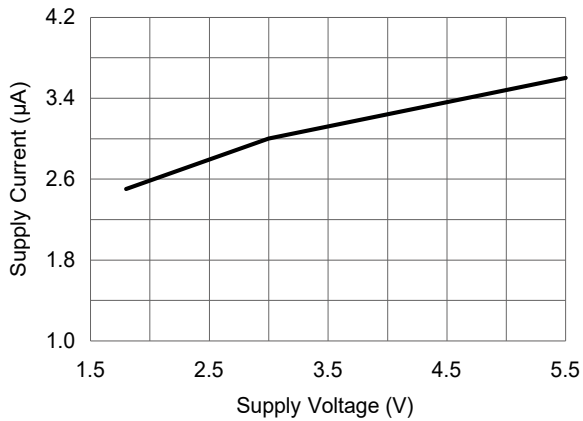

Figure 7. Supply current versus supply voltage ($T_A=25^\circ\text{C}$)

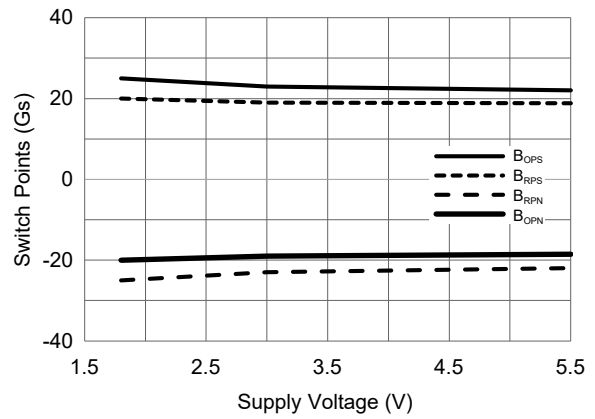

Figure 8. Switch points versus supply voltage ($T_A=25^\circ\text{C}$)

8. Typical Temperature Characteristics

AMR1320S Temperature Characteristics

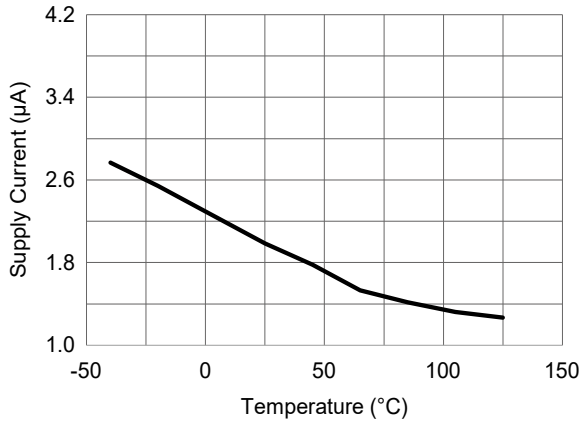

Figure 9. Supply current versus temperature ($V_{CC} = 3\text{ V}$)

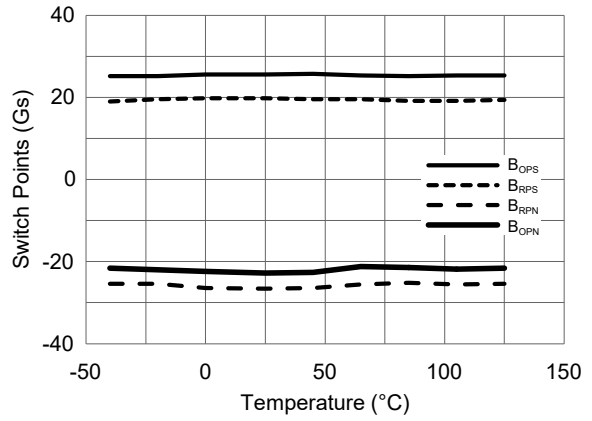

Figure 10. Switch points versus temperature ($V_{CC} = 3\text{ V}$)

AMR1321S Temperature Characteristics

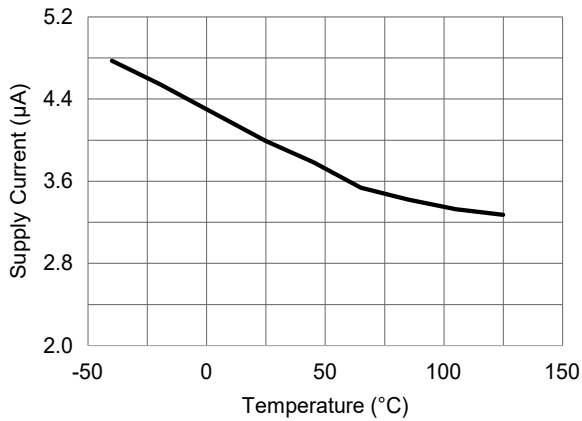

Figure 11. Supply current versus temperature ($V_{CC} = 3\text{ V}$)

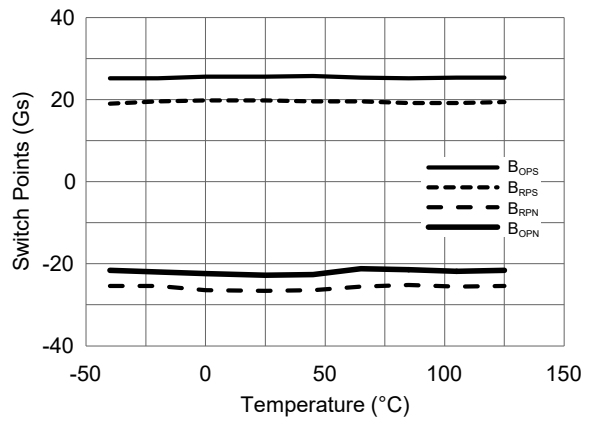

Figure 12. Switch points versus temperature ($V_{CC} = 3\text{ V}$)

9. Application Information

It is recommended to add a filter capacitor with the typical value of 0.1 μF between the switch power supply and ground (close to the sensor) to reduce external noise as shown in Figure 13.

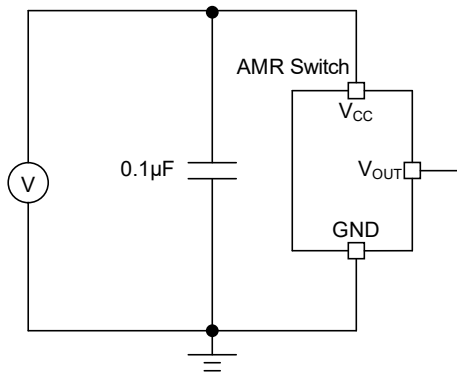

Figure 13. Application circuit diagram

The AMR132x is not suitable for driving power loads. Figure 14 illustrates the general method of improving the drive capability is utilizing the output voltage of V_{OUT} pin as a signal to input the MCU or drive a triode or MOS.

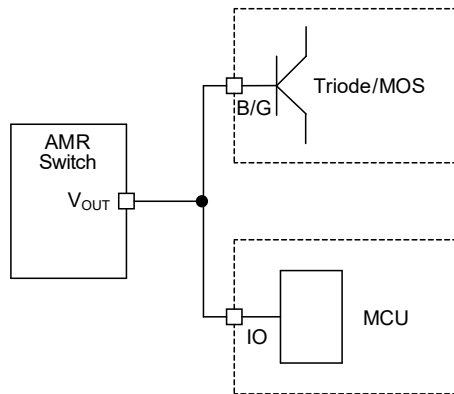

Figure 14. Application diagram for driving power load

Common failure conditions:

- The supply voltage exceeds the limit of absolute maximum ratings
- Absence of matching filter capacitor to power supply when the power supply is unstable, which can cause the product to restart repeatedly
- Using switch output V_{OUT} to control high-power relays, etc., and cause I_{SINK} , I_{SOURCE} exceeding the limit of absolute maximum ratings
- The external magnetic field exceeds the limit of absolute maximum ratings
- Operating in a humid environment for a long time, causing vapor penetration and increased power consumption
- Overheating when soldering
- Over bending of pins

10. Dimensions

SOT23-3 Package

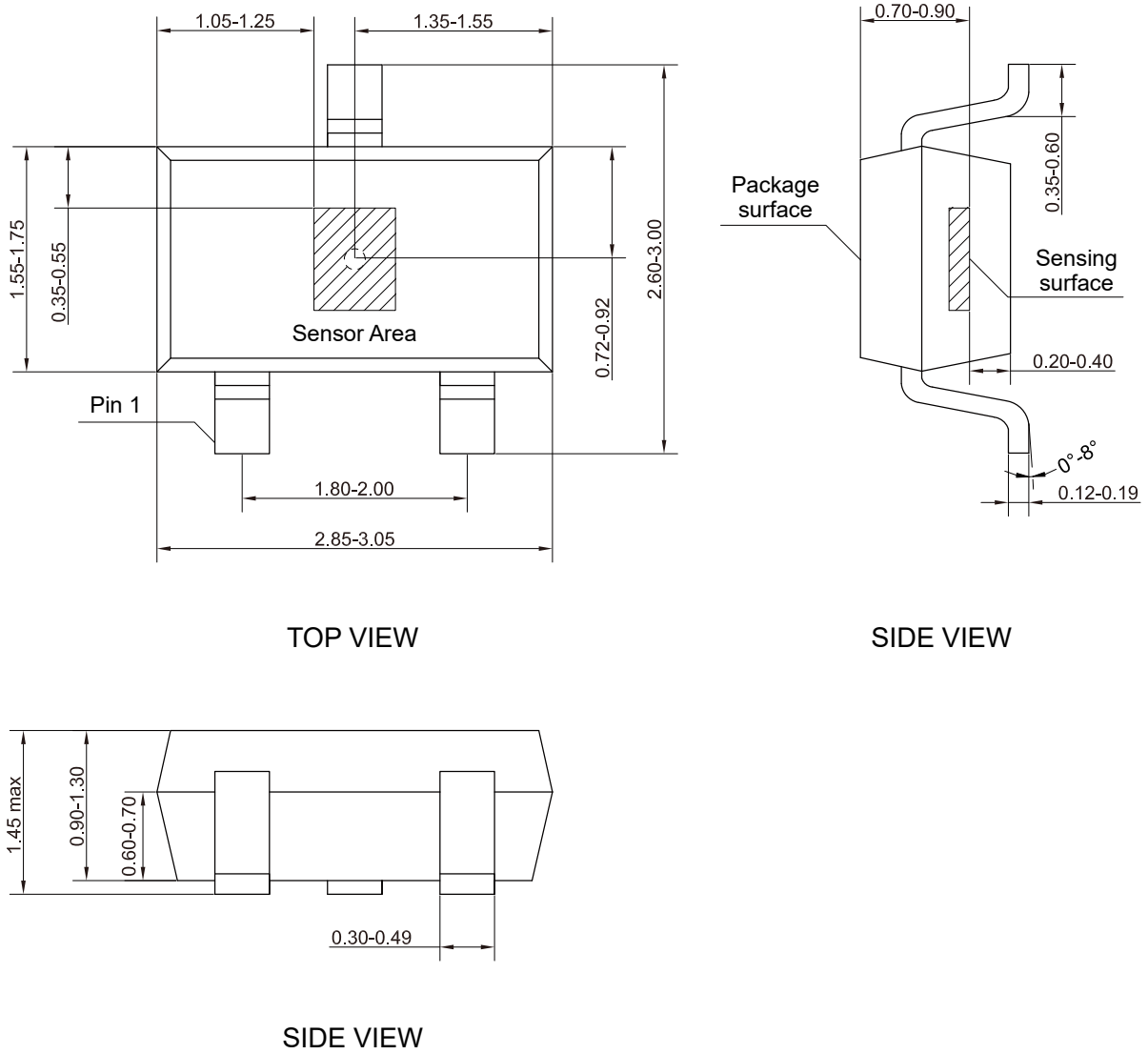

Figure 15. Package outline of SOT23-3 (unit: mm)

Copyright © 2023 by MultiDimension Technology Co., Ltd.

Information furnished herein by MultiDimension Technology Co., Ltd. (hereinafter MDT) is believed to be accurate and reliable. However, MDT disclaims any and all warranties and liabilities of any kind, with respect to any examples, hints or any performance or use of technical data as described herein and/or any information regarding the application of the product, including without limitation warranties of non-infringement of intellectual property rights of any third party. This document neither conveys nor implies any license under patent or other industrial or intellectual property rights. Customer or any third-party must further determine the suitability of the MDT products for its applications to avoid the applications default of customer or third-party. MDT accept no liability in this respect.

MDT does not assume any liabilities of any indirect, incidental, punitive, special or consequential damages (including without limitation of lost profits, lost savings, business interruption, costs related to the removal or replacement of any products or rework charges) whether or not such damages are based on tort (including negligence), warranty, breach of contract or any other legal theory. Notwithstanding any damages that customer might incur for any reason whatsoever, MDT's aggregate and cumulative liability towards customer for the products described herein shall be limited in accordance with the terms and conditions of commercial sale of MDT.

Absolute maximum ratings are the extreme limits the device will withstand without damage to the MDT product. However, the electrical and mechanical characteristics are not guaranteed as the maximum limits (above recommended operating conditions) are approached. MDT disclaims any and all warranties and liabilities of the MDT product will operate at absolute maximum ratings.

Specifications may change without notice.

Please download latest document from our official website www.dowaytech.com/en.

Recycling

The product(s) in this document need to be handed over to a qualified solid waste management services company for recycling in accordance with relevant regulations on waste classification after the end of the product(s) life.



No.2 Guangdong Road, Zhangjiagang Free Trade Zone, Jiangsu, China

Web: www.dowaytech.com/en E-mail: info@dowaytech.com

