

1	COVERING
2	WHEEL CENTRE BODY
3	ROLLING ACTION
4	FIXED PLATE BRACKET
5	
6	TURNING PLATE BRACKET
7	
8	
9	
10	
11	
12	
13	BRAKE
14	
15	STANDARD EXECUTIONS
16	
17	APPLICATIONS
18	

COVERING

Mould-on polyurethane, hardness 95 Shore A.

WHEEL CENTRE BODY

Cast iron.

ROLLING ACTION

Hub with ball bearings. Ideal solution for heavy loads and continuous moving.

FIXED PLATE BRACKET

Electro-welded steel with dark green powder coating. The bracket is designed to withstand loads up to 23000 N. Suitable for heavy industrial applications and for severe conditions of use, such as impact and high speeds.

TURNING PLATE BRACKET

Electro-welded steel with dark green powder coating.

The presence of an axial bearing and a conical bearing ensures excellent manoeuvrability also at full load and increases the resistance of the bracket against side impact. It is equipped with lubricator and anti-loosening system of the locking nut. The bracket is designed to withstand loads up to 23000 N. Suitable for heavy industrial applications and for severe conditions of use, such as impact and high speeds.

It consists of (see Fig.1):

1. fitting plate: forged steel with built-in pin, dark green powder coating;
2. fork: drawn sides electro-welded to the flange, dark green powder coating;
3. rotation system: axial ball bearing and conical roller bearing;
4. lubricator
5. anti-loosening system of the locking nut.

BRAKE

Dual-effect rear brake with simultaneous locking of wheel and bracket. The brake is simple and effective to use: it is actuated and released by a simple action from the top downward at the tip of two separate pedals, thus ensuring the utmost manoeuvring comfort. The braking efficacy may be adjusted with a socket head screw M8.

STANDARD EXECUTIONS

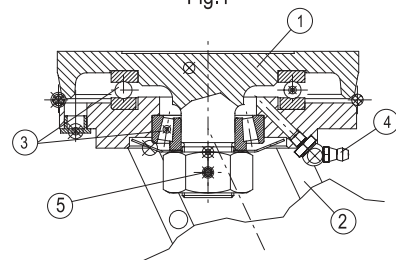
- **PSL-WEH**: fixed plate bracket, without brake.
- **SSL-WEH**: turning plate bracket, without brake.
- **SSF-WEH**: turning plate bracket, with brake.

APPLICATIONS

Suitable for heavy industrial applications and severe conditions of use. The mould-on polyurethane wheels ensure excellent rolling resistance and elasticity, high wear and tearing resistance. For further information see wheel technical data sheet RE.F4 (see page 1834).

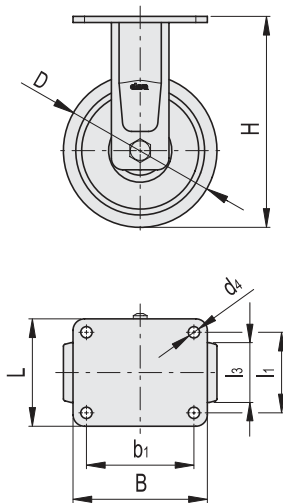


Fig.1

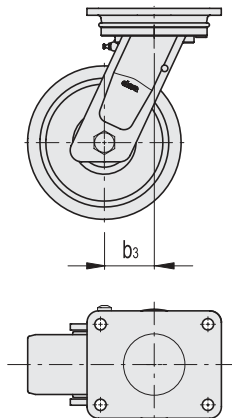


Conversion Table	
1 mm = 0.039 inch	
D	
mm	inch
150	5.91
200	7.87
250	9.84
300	11.81

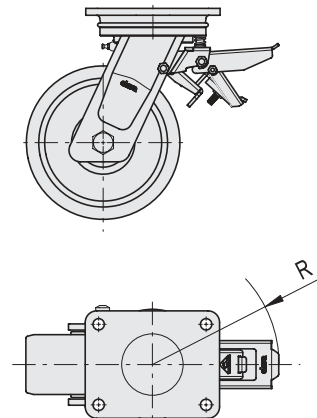
RE.F4-PSL-WEH



RE.F4-SSL-WEH



RE.F4-SSF-WEH



METRIC

Code	Description	D	d4	l1	l3	H	B	L	b1	b3	R	Rolling resistance# [N]	Dynamic carrying capacity# [N]	⚖️
451468	RE.F4-150-PSL-WEH	150	14	105	80	218	175	140	140	-	-	4000	10000	10610
451469	RE.F4-200-PSL-WEH	200	14	105	80	275	175	140	140	-	-	4500	16000	12180
451470	RE.F4-250-PSL-WEH	250	17	120	80	325	200	160	160	-	-	5000	19000	15230
451472	RE.F4-300-PSL-WEH	300	17	120	80	365	200	160	160	-	-	6000	23000	19320
451428	RE.F4-150-SSL-WEH	150	14	105	80	218	175	140	140	50	-	4000	10000	12150
451429	RE.F4-200-SSL-WEH	200	14	105	80	275	175	140	140	65	-	4500	16000	13720
451430	RE.F4-250-SSL-WEH	250	17	120	80	325	200	160	160	74	-	5000	19000	17560
451432	RE.F4-300-SSL-WEH	300	17	120	80	365	200	160	160	81	-	6000	23000	21670
451449	RE.F4-150-SSF-WEH	150	14	105	80	218	175	140	140	50	166	4000	10000	13030
451450	RE.F4-200-SSF-WEH	200	14	105	80	275	175	140	140	65	166	4500	16000	14600
451451	RE.F4-250-SSF-WEH	250	17	120	80	325	200	160	160	74	166	5000	19000	18440
451452	RE.F4-300-SSF-WEH	300	17	120	80	365	200	160	160	81	166	6000	23000	22550

For rolling resistance and dynamic carrying capacity see Technical data on page 1880.

