

Features

- Complete Touchscreen Module:
 - Projected Capacitive Multi Touch Controller
 - 7in LCD
 - 4 Capacitive “Navigation” Keys
 - 200 bytes non-volatile serial EEPROM
- Touch:
 - Atmel maXTouch™ mXT640T Touch Controller
 - Supports up to 10 touches
- Display:
 - 800x480 resolution
 - ≤30 ms response time
 - White LED backlight
 - 18-bit RGB
- Navigation Keys:
 - Atmel AT42QT1070 QTouch™ Button Sensor IC
- Cover Panel:
 - 1.1mm Dragontrail™



PDA TM7000B: 7in PCAP Touch Module

P/N: 90-00106-A0



Visit <http://www.pdaatl.com/tm7000b>
for the latest information on the TM7000B

Doc: 111-00217-A2

Contents

1	Module Overview	4
1.1	PCB Connections	4
1.2	LCD Backlight Power J1	5
1.3	Host Connector J3	6
1.4	Host Connector J5	7
1.5	Host Interface (Combined) J6	8
1.6	Display Flex Connector J7	9
2	Overview of the 7in PCAP Touch Module	10
2.1	Introduction	10
2.2	Understanding Unfamiliar Concepts	11
2.3	LCD Panel	11
2.3.1	Scan Direction Selection	11
2.3.2	RGB Signal Routing	12
2.4	maXTouch Capacitive Touchscreen Controller	13
2.4.1	maXTouch Controller Interface	13
2.5	QTouch Capacitive Button Controller	14
2.5.1	QTouch Controller Interface	14
2.6	Serial EEPROM	14
3	Getting Started	15
3.1	Hardware Connections	15
3.2	Software	15
3.3	Using the Touch Module	15
3.3.1	Navigation Keys	15
3.3.2	Evaluating the Touch Module	16
4	Specifications	17
4.1	Mechanical Specifications	17
4.2	Absolute Maximum Specifications	19
4.3	Recommended Operating Conditions	19
4.4	DC Specifications	19
4.5	I2C-compatible Bus Specifications	20
4.6	LCM Specification	20
4.6.1	LCM Parameters	20
4.6.2	LCM Absolute Maximum Specifications	21
4.6.3	LCM DC Specifications	21
4.6.4	LCM Optical Characteristics	21

4.7	Power Consumption	22
4.8	Part Number	22
5	I2C Basics (I2C-compatible Operation)	23
5.1	Interface Bus	23
5.2	Transferring Data Bits	23
5.3	START and STOP Conditions	23
5.4	Address Byte Format	24
5.5	Data Byte Format	24
5.6	Combining Address and Data Bytes into a Transmission	25
6	Revision History	26
7	Notes	27

1 Module Overview

1.1 PCB Connections

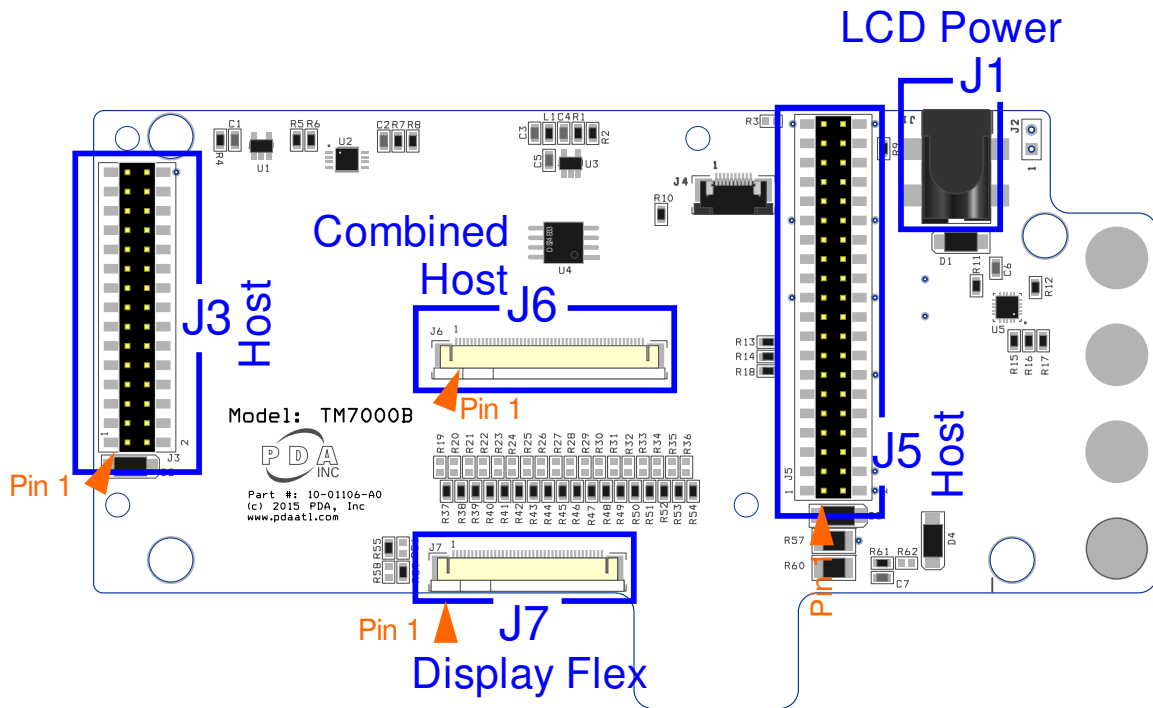

Figure 1 - PCB Connectors

NOTE: Insert flex in Connector J6 with contacts facing DOWN.

The following notations are used for pin descriptions:

I	Input only	OD	Open drain output
O	Output only, push-pull	P	Ground or power
MXT	maXTouch touchscreen	QT	QTouch Button Controller
EE	Serial EEPROM	LCD	LCD Panel

NOTE: Inputs and output are defined from the standpoint of the Touch Module.

1.2 LCD Backlight Power J1

Connector J1 is used to provide +5Vdc system and LCD backlight power to the touch module when the [Connector J6](#) host interface is being used. The host interface on connector [J6](#) only provides +3.3Vdc system power. By contrast, when the TM7000B is connected to the host via connectors [J3](#) and [J5](#), system power and LCD backlight power is provided through those interfaces.



NOTE: J1 should NOT be used when J3 and J5 are in use.

The mating connector for J1 is a 2.1mm I.D x 5.5mm O.D barrel connector (center positive). A +5Vdc supply rated for 1A minimum should be used.

Suggested power supplies:

- Pihong PSC12R-050, (+5Vdc, 2A)
- Pihong PSAC05R-050(P), (+5Vdc, 1A)

1.3 Host Connector J3

Connector J3 connects to the host and carries signals between the host and (1) the MaXTouch Touch Controller, (2) the QTouch Button Controller and (3) LCD Panel.



NOTE: J3 (and J5) should NOT be used when J6 is in use.

Take care to support the PCB when removing the touch module from an EK

J1 should NOT be used when J3 (and J5) are in use.

Pin	Type	Description	MXT	LCD	QT	EE
1	P	+3.3Vdc				
2	P	GND	•			
3	P	+3.3Vdc				
4	P	GND				
5	O	~MXT_CHG	•			
6	O	~QT_CHG			•	
7	I	I ² C SCL	•		•	
8	I/O	I ² C SDA	•		•	
9	P	GND				
10	I	LCD_DATA_15		•		
11	P	GND				
12	I	LCD_DATA_13		•		
13	P	GND				
14	I	LCD_DATA_14		•		
15	P	GND				

Pin	Type	Description	MXT	LCD	QT	EE
16	I	LCD_DATA_12		•		
17	P	GND				
18	I	LCD_DATA_0		•		
19	I	LCD_DATA_1		•		
20	I	LCD_DATA_2		•		
21	I	LCD_DATA_3		•		
22	I	LCD_DATA_4		•		
23	I	LCD_DATA_5		•		
24	I	LCD_DATA_6		•		
25	I	LCD_DATA_7		•		
26	I	LCD_DATA_8		•		
27	I	LCD_DATA_9		•		
28	I	LCD_DATA_10		•		
29	I	LCD_DATA_11		•		
30	P	GND				

1.4 Host Connector J5

Connector J5 connects to the host and carries signals between the host and (1) the LCD Panel and (2) serial EEPROM.



NOTE: J5 (and J3) should NOT be used when J6 is in use.

Take care to support the PCB when removing the touch module from an EK

J1 should NOT be used when J5 (and J3) are in use.

Pin	Type	Description	MX	LT	QT	EE
1	P	+5Vdc				
2	P	GND				
3	P	+5Vdc				
4	P	GND				
5	I	LCD_DATA_16		•		
6	I	LCD_DATA_17		•		
7	I	LCD_DATA_18		•		
8	I	LCD_DATA_19		•		
9	I	LCD_DATA_20		•		
10	I	LCD_DATA_21		•		
11	I	LCD_DATA_22		•		
12	I	LCD_DATA_23		•		
13	P	GND				
14	P	GND				
15	I	DISP (Display Enable)		•		
16	I	Backlight PWM		•		
17	I	VSYNC		•		
18	I	HSYNC		•		
19	I	DE		•		
20	I	PCLK		•		

Pin	Type	Description	MX	LT	QT	EE
21	P	GND				
22	P	GND				
23	-	N/C				
24	-	N/C				
25	-	N/C				
26	-	N/C				
27	-	N/C				
28	I/O	One-Wire Interface				•
29	P	GND				
30	P	GND				
31	-	N/C				
32	-	N/C				
33	-	N/C				
34	-	N/C				
35	-	N/C				
36	O	Module Presence Detect				
37	-	N/C – See Note 1				
38	-	N/C				
39	P	GND				
40	P	GND				

Note 1: by populating R3, the touch module's ~RESET signal is accessible at this pin.

1.5 Host Interface (Combined) J6

Connector J6 implements Atmel's "XPRO LCD" connector found on various Xplained and Xplained Pro evaluation kits.

Connector J6 connects to the host and carries the combined signals of [J3](#) and [J5](#). It provides an alternate interface between the host and (1) the MaXTouch Touch Controller, (2) the QTouch Button Controller, (3) LCD Panel, and (4) serial EEPROM.

When the host interface on connector J6 is used, +5Vdc system power must be provided using [Connector J1](#). See Section 1.2 for details.

Suggested Flex:

Wurth Electronics #687 650 100 002,
Description: 0.5mm pitch 50 position FFC, Length 100mm

See section 2.3.2 for additional information on flex cable options.

Flex should be inserted Connector J6 with contacts facing DOWN.

NOTE: J6 should NOT be used when J3 and J5 are in use.

Pin	Type	Description	MXT	LCD	QT	EE
1	I/O	One-Wire Interface				•
2	P	GND				
3	I	LCD_DATA_0		•		
4	I	LCD_DATA_1		•		
5	I	LCD_DATA_2		•		
6	I	LCD_DATA_3		•		
7	P	GND				
8	I	LCD_DATA_4		•		
9	I	LCD_DATA_5		•		
10	I	LCD_DATA_6		•		
11	I	LCD_DATA_7		•		
12	P	GND				
13	I	LCD_DATA_8		•		
14	I	LCD_DATA_9		•		
15	I	LCD_DATA_10		•		
16	I	LCD_DATA_11		•		
17	P	GND				
18	I	LCD_DATA_12		•		
19	I	LCD_DATA_13		•		
20	I	LCD_DATA_14		•		
21	I	LCD_DATA_15		•		
22	P	GND				
23	I	LCD_DATA_16		•		
24	I	LCD_DATA_17		•		
25	I	LCD_DATA_18		•		

Pin	Type	Description	MXT	LCD	QT	EE
26	I	LCD_DATA_19		•		
27	P	GND				
28	I	LCD_DATA_20		•		
29	I	LCD_DATA_21		•		
30	I	LCD_DATA_22		•		
31	I	LCD_DATA_23		•		
32	P	GND				
33	I	PCLK		•		
34	I	VSYNC		•		
35	I	HSYNC		•		
36	I	DE		•		
37	-	N/C				
38	-	N/C				
39	-	N/C				
40	-	N/C				
41	I	DISP		•		
42	I	I ² C SDA	•		•	
43	I/O	I ² C SCL	•		•	
44	O	~MXT_CHG	•			
45	O	~QT_CHG			•	
46	I	LCD_PWM		•		
47	I	~RESET	•		•	
48	P	+3.3Vdc				
49	P	+3.3Vdc				
50	P	GND				

1.6 Display Flex Connector J7

Connector J7 connects to the LCD panel flex and carries signals between the host and the LCD Panel.

Pin	Type	Description
1	O	U/D
2	O	L/R
3	P	GND
4	O	PCLK
5	P	GND
6	O	R0
7	O	R1
8	O	R2
9	P	GND
10	O	R3
11	O	R4
12	O	R5
13	P	GND
14	O	G0
15	O	G1
16	O	G2
17	P	GND
18	O	G3
19	O	G4
20	O	G5

Pin	Type	Description
21	P	GND
22	O	B0
23	O	B1
24	O	B2
25	P	GND
26	O	B3
27	O	B4
28	O	B5
29	P	GND
30	O	HSYNC
31	O	VSYNC
32	O	DE
33	O	MODE
34	P	+3.3Vdc
35	P	+3.3Vdc
36	P	LED-
37	P	LED-
38	O	LCD_PWM
39	P	LED+
40	P	LED+

2 Overview of the 7in PCAP Touch Module

2.1 Introduction

The 7in PCAP Touch Module is a touchscreen module offering best-in-class projected capacitance multi-touch functionality combined with a 7in LCD panel. The module is configured for development and evaluation with several Atmel ARM-based EK solutions as well as development and integration with a custom host system.

For convenience, this module features host interface connectors (J3 and J5) positioned for direct installation on Atmel ARM-based EK boards. In addition, the module includes Atmel's "Xplained Pro LCD" connector (J6) for use with Xplained and XPro evaluation hardware.

As shown in Figure 2 below, several sub-system components are accessible to maximize effective integration.

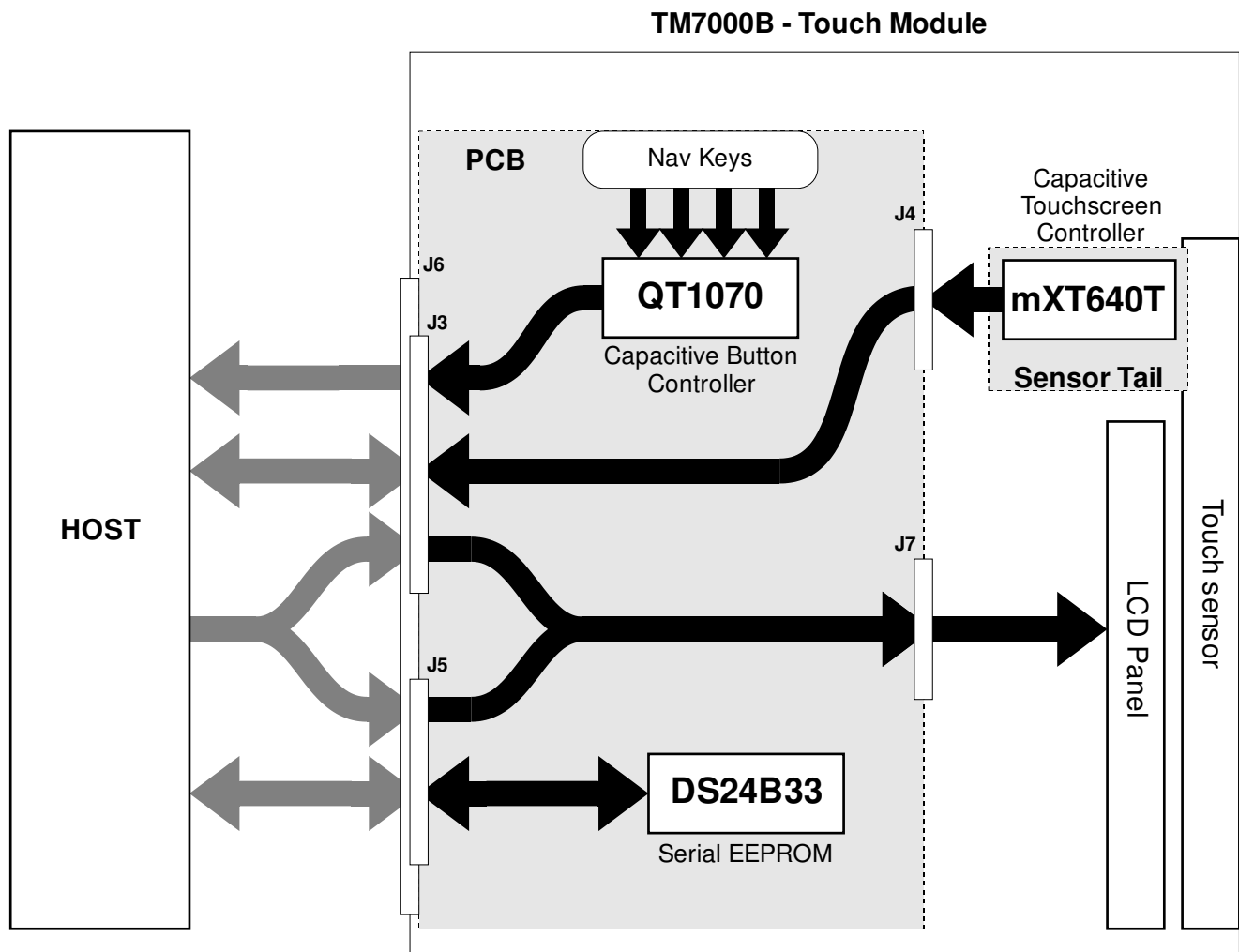

Figure 2 - Functional Block Diagram

2.2 Understanding Unfamiliar Concepts

Throughout this document, the functionality of the module sub-system will be outlined and summarized. However, the user is encouraged to refer to the resources and documents below in order to gain a more thorough understanding of each sub-system.

- For a basic overview of I²C communication, refer to [Section 5](#) of this document
- Atmel maXTouch mXT640T (www.atmel.com)
- Atmel QTouch QT1070 Datasheet (www.atmel.com)
- Maxim DS24B33 Datasheet (www.maximintegrated.com)

In addition, when developing or evaluating with the Atmel ARM-based EK's, it is recommended that the user visit www.at91.com which contains a broad range of resources for the EK's and the ARM devices they feature.

2.3 LCD Panel

The module provides the host with a direct connection from the host ([Connector J6](#) or [Connectors J3 and J5](#)) to the LCD panel interface ([Connector J7](#)). Aside from generating supply voltages for the LED backlight and providing backlight control to the host, no display panel control is performed by the module.

2.3.1 Scan Direction Selection

The touch module provides a means for configuring the scan direction of the LCD by populating resistors indicated in Figure 3 below.

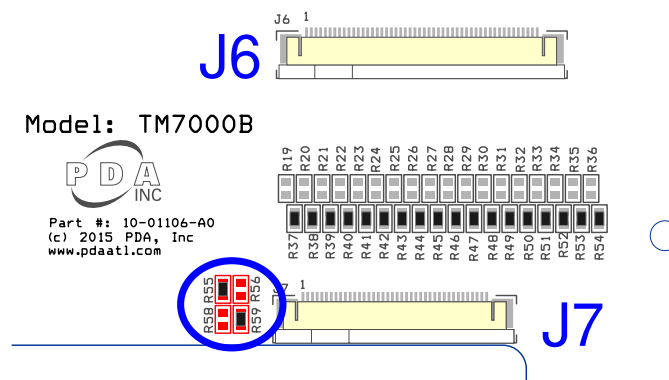

Figure 3 – LCD Scan Direction Configuration Resistors

The LCD panel Up/Down scanning direction is configured by populating R55 and R58 as shown in Table 2-1 below. The LCD panel Left/Right scanning direction is configured by populating R56 and R59 as shown in Table 2-2 below.

Table 2-1 - LCD Up/Down Scanning Selection

R55	R58	Direction
0 Ω	DNP	Down
DNP	0 Ω	Up

Note: Factory setting is scanning “Down”

Table 2-2 - LCD Left/Right Scanning Selection

R56	R59	Direction
0 Ω	DNP	Left
DNP	0 Ω	Right

Note: Factory setting is scanning “Right”

2.3.2 RGB Signal Routing

To support use with multiple host EK options, the touch module provides a means for selecting the routing of LCD_DAT_xx signals to the LCD RGB data signals by populating one of the two groups of resistors indicated in Figure 4 below.

As an alternative, an adapter flex cable (P/N: 91-00112-A0) is available which handles this signal routing without the need for soldering and moving resistors on the PCB. Contact PDA for more information.

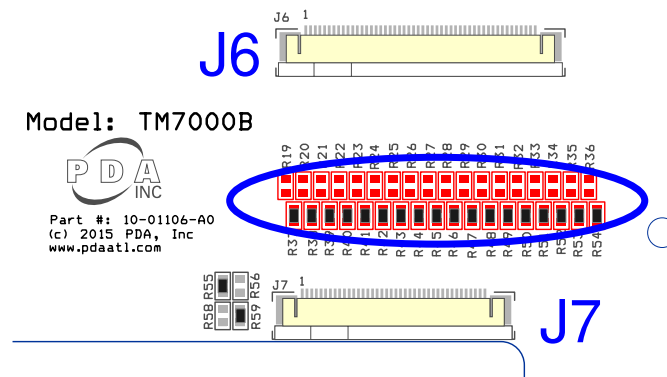

Figure 4 – RGB Signal Routing Configuration Resistors

Populating resistors R37-R54 selects the Atmel “Series-5 / A5D3x” routing scheme. Populating resistors R19-R36 selects the Atmel “Islero” routing scheme used on newer A5D4 and A5D2 Xplained and Xplained PRO kits. The PCB ships with R37-R54 populated – selecting the “Series-5 / A5D3x” scheme by default.

Details of each scheme are shown in Table 2-3 below.

Table 2-3 – RGB Signal Routing Selection

Series 5/A5D3x (R37 – R54 populated)	“Islero” (R19 – R36 populated)	LCM
LCD_DAT_17	LCD_DAT_23	R5
LCD_DAT_16	LCD_DAT_22	R4
LCD_DAT_15	LCD_DAT_21	R3
LCD_DAT_14	LCD_DAT_20	R2
LCD_DAT_13	LCD_DAT_19	R1
LCD_DAT_12	LCD_DAT_18	R0
LCD_DAT_11	LCD_DAT_15	G5
LCD_DAT_10	LCD_DAT_14	G4
LCD_DAT_9	LCD_DAT_13	G3
LCD_DAT_8	LCD_DAT_12	G2
LCD_DAT_7	LCD_DAT_11	G1
LCD_DAT_6	LCD_DAT_10	G0
LCD_DAT_5	LCD_DAT_7	B5
LCD_DAT_4	LCD_DAT_6	B4
LCD_DAT_3	LCD_DAT_5	B3
LCD_DAT_2	LCD_DAT_4	B2
LCD_DAT_1	LCD_DAT_3	B1
LCD_DAT_0	LCD_DAT_2	B0

Note: Factory setting is “Series 5/A5D3x”

See the AT91 Linux4SAM website for additional details:

<https://www.linux4sam.org/bin/view/Linux4SAM/ConnectModuleFromPDA>

2.4 maXTouch Capacitive Touchscreen Controller

The module touch screen interface is based on the Atmel maXTouch mXT640T Touch Controller and operates using the touch sensor at [connector J4](#).

The touch controller scans the touch sensor and will signal the host with an active low interrupt signal (~MXT_CHG on [J3](#) or [J6](#)) when new touch data is available. Data communication with the maXTouch controller is performed over a shared I²C interface (I²C SCL and I²C SDA on [J3](#) or [J6](#)). The I²C address of the touch controller is 0x4A.

NOTE: The TM7000B has pull-up resistors on the shared I²C SCL and SDA lines at R7 and R8 respectively. A pull-up resistor for the maXTouch ~CHG interrupt signal is located at R4.

2.4.1 maXTouch Controller Interface

Details of the maXTouch communication protocol are beyond the scope of this document. However information is provided in Section 3.2 below to facilitate evaluation and initial development.



This module is pre-loaded with a configuration already optimized for this touch sensor and panel, so the developer need only focus on interfacing with the device. When developing the maXTouch controller interface during evaluation and host development, care should be taken to avoid changing the maXTouch configuration or committing changes to NV storage on the maXTouch controller.

To get started with host interface development, the user is *strongly* encouraged to leverage existing code available from the resources outlined in Sections 3.2.

2.5 QTouch Capacitive Button Controller

The module's "nav key" interface is based on the Atmel QT1070 7-Channel Capacitive Sensor Driver.

The button controller scans the 4 capacitive nav keys (K1, K2, K3 and K4) and will signal the host with an active low interrupt signal (~QT_CHG on [Connector J3](#) or [J6](#)) when a touch event has occurred. Data communication with the QT1070 controller is performed over a shared I²C interface (I²C SCL and I²C SDA on [J3](#) or [J6](#)). The I²C address of the button controller is 0x1B and cannot be changed.

NOTE: The TM7000B has pull-up resistors on the shared I²C SCL and SDA lines at R7 and R8 respectively. QTouch ~CHG interrupt signal is located at R16.

2.5.1 QTouch Controller Interface

Details of the QTouch communication protocol are beyond the scope of this document. The user is encouraged to review the QT1070 Datasheet (www.atmel.com).

2.6 Serial EEPROM

The module includes a DS24B33 Serial EEPROM providing 512 bytes of non-volatile storage. Data communication with the EEPROM is performed over a One-Wire Interface. The EEPROM is not used by another subsystem on the touch module and can be freely used by the host system for any purpose. For example, Atmel ARM-based EK's running Linux or Android operating systems use the pre-programmed contents of the EEPROM to identify this module type.



NOTE: The user should take care if choosing to overwrite the pre-programmed EEPROM contents. As noted above, certain builds of Linux or Android provided by Atmel and targeted for the Atmel ARM-based EKs use the EEPROM contents to identify the module and may no longer recognize the module. The user is advised to back up the EEPROM contents before overwriting.

The serial EEPROM communicates via a one-wire interface ("One-Wire Interface" on [J5](#) or [J6](#)). Refer to the DS24B33 Datasheet (www.maximintegrated.com) for details.

3 Getting Started

This module was designed to install on a variety of Atmel ARM-based EK's including the SAM9X5-EK, SAM9N12-EK, SAMA5D3-EK, SAMA5D3 Xplained, SAMA5D4-EK, and the SAMA5D4 Xplained Ultra among others. With prebuilt Linux and/or Android images available for these evaluation platforms, this provides the fastest way to evaluate the performance of the touchscreen and display using a familiar, full-featured OS.

The following sections provide basic information related to using and evaluating the Touch Module. Visit Precision Design Associates website (www.pdaatl.com) or Atmel's AT91 Community website (www.at91.com) for more information related to this touch module or guidance appropriate for your specific EK.

3.1 Hardware Connections

The module interfaces with the evaluation board via one of two methods depending on the eval hardware:

- the two large dual-row headers, [J3](#) and [J5](#) (typically found on full-sized EK kits)
- the flex connector, [J6](#) (typically found on Xplained or Xplained Ultra kits)

Refer to the specific EK documentation to determine which method is appropriate.

3.2 Software

Several options exist when developing for the touch module whether targeting a custom host or an Atmel EK.

3.2.1.1 Linux Kernel / Android

The Linux Kernel (www.kernel.org) has included basic support for maXTouch touch devices since version 2.6.36. The mainline driver has undergone considerable evolution since then.

Atmel hosts the AT91 community website with resources dedicated to developing on their EKs for Android (www.at91.com/android4sam/) and Linux (www.at91.com/linux4sam/)

Finally, Atmel maintains an up-to-date driver (www.github.com/atmel-maxtouch/linux) which includes numerous out-of-cycle improvements to the mainline Linux Kernel maXTouch driver.

3.2.1.2 Atmel Software Framework





The Atmel Software Framework (asf.atmel.com) contains examples of code for interfacing with devices in the maXTouch family of touch controllers. The capabilities of various maXTouch devices may differ, but the basic communication protocol is common and can be applied to this module.

3.3 Using the Touch Module

3.3.1 Navigation Keys

When using this module with one of the standard Atmel Android demo builds, the navigation keys function as shown in Table 3-1 below:

Table 3-1 - Navigation Key Function (Android)

Key	Navigation Function
K1	 Back
K2	 Menu
K3	 Home
K4	 Power / Sleep

3.3.2 Evaluating the Touch Module

For effective evaluation of the module – the touch sensor and the LCD panel in particular – the user is encouraged to try the following applications and tools depending on the host OS.

3.3.2.1 Android

The following Android apps available from Google Play:

[TouchTest](#) by Moonblink

[Doty](#) by Gerry Steele

[Multitouch Visible Test](#) by Battery Powered Games

[Screen Test](#) by Amberfog

3.3.2.2 Linux

The user can perform simple touch / drawing test using the `ts_test` utility that is part of `tslib`.

4 Specifications

For complete specifications, refer to the datasheets listed in section 2.2 for the various sub-system components outlined in sections 2.3 through 2.6.

4.1 Mechanical Specifications

Contact PDA for drawings and CAD models available.

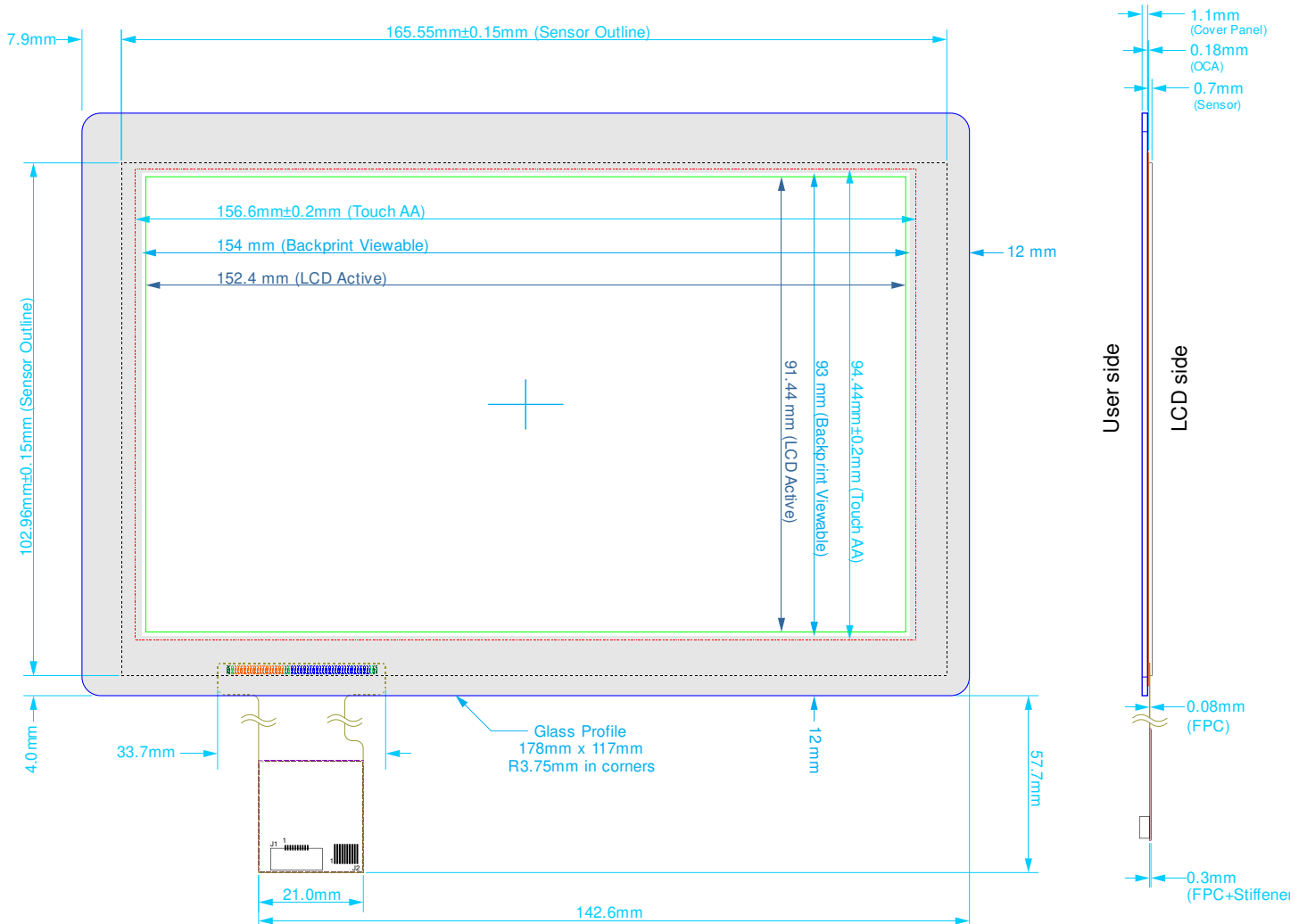

Figure 5 - Sensor Only Dimensions

Sensor Assy (P/N: 90-00087-A0) may be purchased individually.
Minimum order quantities apply. Contact PDA for details.

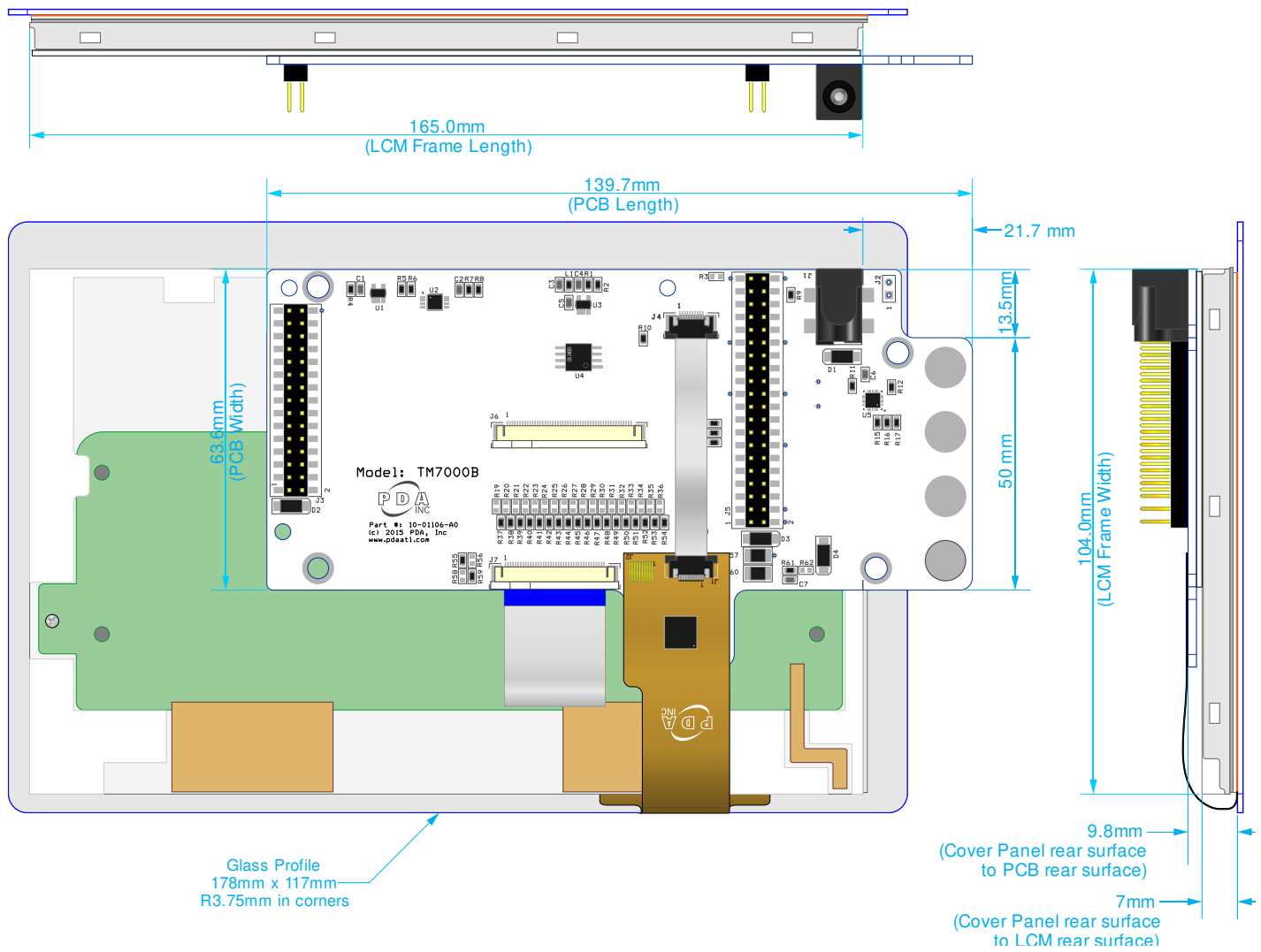



Figure 6 – Module Dimensions

4.2 Absolute Maximum Specifications

Parameter	Value
Operating temp	0°C to + 70°C
Storage temp	-40°C to + 85°C
Vdd	-0.5 to +6V
Max continuous pin current, any control or drive pin	±40 mA
Voltage forced onto any pin	-0.5V to (Vdd + 0.5) Volts
 CAUTION: Stresses beyond those listed under <i>Absolute Maximum Specifications</i> may cause permanent damage to the device. This is a stress rating only and functional operation of the device at these or other conditions beyond those indicated in the operational sections of this specification are not implied. Exposure to absolute maximum specification conditions for extended periods may affect device reliability.	

4.3 Recommended Operating Conditions

Parameter	Value
V _{in}	5.0V ±5 percent
Supply ripple + noise	±20 mV

4.4 DC Specifications

V_{in} = 5.0V, V_{dd}=3.3Vdc, T_a = recommended range, unless otherwise noted

Parameter	Description	Min	Typ	Max	Units	Notes
V _{IL}	Low input logic level	- 0.5	–	0.3 V _{dd}	V	1.8V <V _{dd} <3.3V
V _{HL}	High input logic level	0.7 V _{dd}	–	V _{dd} + 0.5	V	1.8V <V _{dd} <3.3V
V _{OL}	Low output voltage	–	–	0.2V _{dd}	V	
V _{OH}	High output voltage	0.8V _{dd}	–	–	V	
I _{IL}	Input leakage current	–	–	1	µA	

4.5 I2C-compatible Bus Specifications

Parameter	Operation
Touchscreen Controller Address	0x4A
Navigation Key Controller Address	0x1B
Maximum bus speed (SCL)	400 kHz
I2C Specification	Version 2.1

4.6 LCM Specification

Specifications in this section apply only to the LCD panel.

4.6.1 LCM Parameters

Parameter	Value
Display Size	7in
LCD Type	α -Si TFT active matrix
Display Mode	Normally White, Transmissive
Resolution	800 x RGB x 480
View Direction (Best Image)	12 o'clock
Dimensions	165mm (H) x 104mm (W) x 5.5mm (T)
Active Area	152.4mm (W) x 91.44mm (H)
Dot Pitch	0.0635mm (W) x 0.1905mm (H)
Pixel Arrangement	RGB Stripe
Display Colors	262K
Interface	Digital (TTL)
Weight	130g

4.6.2 LCM Absolute Maximum Specifications

Parameter	Description	Min	Max	Units
V _{CC}	Power Voltage	-0.3	6	V
V _{LED}	LED Voltage	0	5.5	V
V _I	Input Voltage	- 0.3	6.3	V
T _{STG}	Storage temperature	-30	80	°C
T _{OP}	Operating temperature	-20	70	°C
 CAUTION: Stresses beyond those listed under LCM <i>Absolute Maximum Specifications</i> may cause permanent damage to the device. This is a stress rating only and functional operation of the device at these or other conditions beyond those indicated in the operational sections of this specification are not implied. Exposure to absolute maximum specification conditions for extended periods may affect device reliability.				

4.6.3 LCM DC Specifications

Parameter	Description	Min	Typ	Max	Units
V _{CC}	Power Supply	3.1	3.3	3.5	V
V _{LED}	LED Supply	4.8	5.0	5.2	V
I _{CC}	Current Consumption	-	250	300	mA
I _{LED}	LED Current Consumption	-	500	550	mA
V _{IL}	Low input logic level	0	-	0.3 V _{CC}	V
V _{IH}	High input logic level	0.7 IOV _{CC}	-	V _{CC}	V

4.6.4 LCM Optical Characteristics

Backlight On (Transmissive Mode).

Parameter	Description	Min	Typ	Max	Units
L	Luminance	240	300	-	cd/m ²
Y _U	Luminance uniformity	70	75	-	%
CR	Contrast Ratio	400	500	-	
T _{ON}	Response Time (fall: 90% to 10%)	-	10	20	ms
T _{OFF}	Response Time (time: 10% to 90%)	-	15	30	ms
W _X	Color Chromaticity	0.26	0.31	0.36	-
W _Y		0.28	0.33	0.38	-

4.7 Power Consumption

Vdd (V)	Mode	Idd (mA)
+3.3Vdc	maXTouch controller in Free Run, LCD backlight on maximum intensity	300 max
+5Vdc		650

4.8 Part Number

Part Number	Description
90-00106-A0	TM7000B: 7in PCAP Touch Module

5 I2C Basics (I2C-compatible Operation)

5.1 Interface Bus

The device communicates with the host over an I²C-compatible bus, in accordance with version 2.1 of the I²C specification. The following sections give an overview of the bus; more detailed information is available from www.i2c-bus.org. Devices are connected to the I²C-compatible bus as shown in Figure 7 both bus lines are connected to Vdd via pull-up resistors. The bus drivers of all I²C-compatible devices must be open-drain type. This implements a wired “AND” function that allows any and all devices to drive the bus, one at a time. A low level on the bus is generated when a device outputs a zero.

Figure 7. I²C-compatible Interface Bus

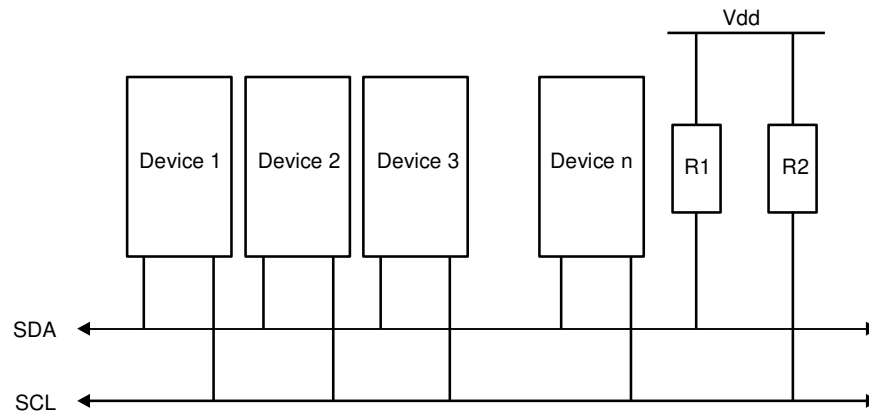

5.2 Transferring Data Bits

Each data bit transferred on the bus is accompanied by a pulse on the clock line. The level of the data line must be stable when the clock line is high; the only exception to this rule is for generating START and STOP conditions.

Figure 8. Data Transfer

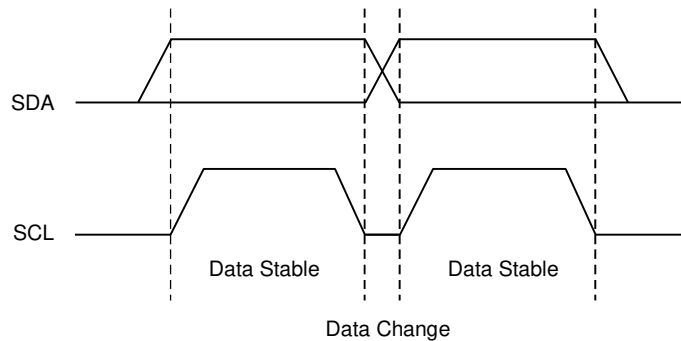

5.3 START and STOP Conditions

The host initiates and terminates a data transmission. The transmission is initiated when the host issues a START condition on the bus, and is terminated when the host issues a STOP condition. Between the START and STOP conditions, the bus is considered busy. As shown in Figure 9 START and STOP conditions are signaled by changing the level of the SDA line when the SCL line is high.

Figure 9. START and STOP Conditions

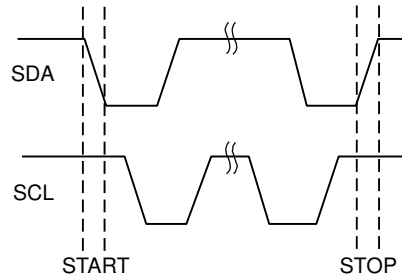

5.4 Address Byte Format

All address bytes are 9 bits long. They consist of 7 address bits, one READ/WRITE control bit and an acknowledge bit. If the READ/WRITE bit is set, a read operation is performed. Otherwise a write operation is performed. An address byte consisting of a slave address and a READ or a WRITE bit is called SLA+R or SLA+W, respectively. When the device recognizes that it is being addressed, it acknowledges by pulling SDA low in the ninth SCL (ACK) cycle.

The most significant bit of the address byte is transmitted first.

Figure 10. Address Byte Format

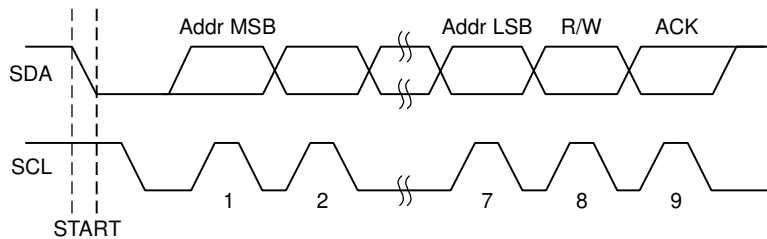

5.5 Data Byte Format

All data bytes are 9 bits long, consisting of 8 data bits and an acknowledge bit. During a data transfer, the host generates the clock and the START and STOP conditions. The slave device is responsible for acknowledging the reception. An acknowledge (ACK) is signaled by the slave device pulling the SDA line low during the ninth SCL cycle. If the slave device leaves the SDA line high, a NACK is signaled.

Figure 11. Data Byte Format

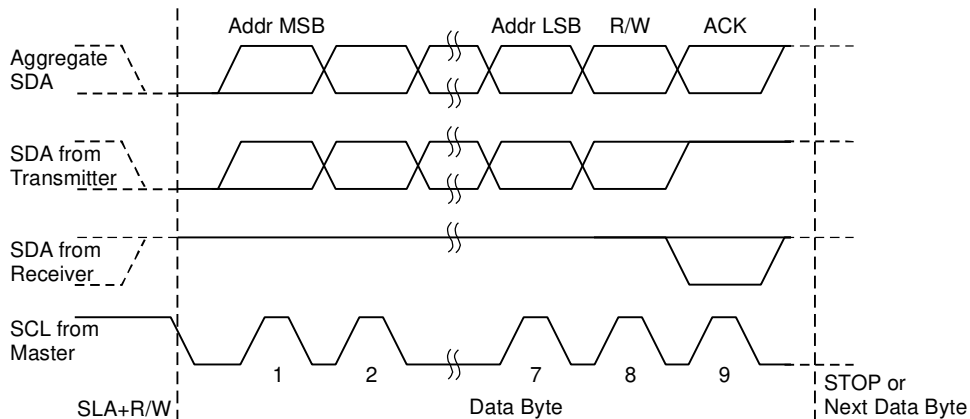

5.6 Combining Address and Data Bytes into a Transmission

A transmission consists of a START condition, an SLA+R or SLA+W, one or more data bytes and a STOP condition. The wired “ANDing” of the SCL line is used to implement handshaking between the host and the device. The device extends the SCL low period by pulling the SCL line low whenever it needs extra time for processing between the data transmissions.

Figure 12 shows a typical data transmission. Note that several data bytes can be transmitted between the SLA+R or SLA+W and the STOP.

Figure 12. Byte Transmission

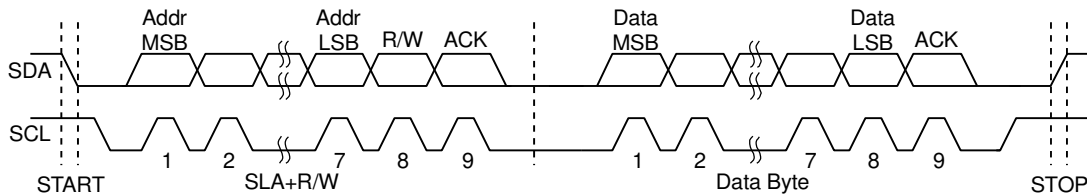

6 Revision History

Revision No.	History
Rev A0	Initial Release
Rev A1	Corrected LCM frame dimension in top view of Figure 6
Rev A2	Corrected resistor ranges shown in Table 2-3

7 Notes



email: sales@pdaatl.com

Precision Design Associates, Inc.

645 Hembree Parkway, Suite G
Roswell, GA 30076
USA

tel: (770)-664-0448



url: <http://www.pdaatl.com>

© 2015 Precision Design Associates. All rights reserved. Atmel®, Atmel logo and combinations thereof, maXTouch®, QTtouch®, and others are registered trademarks of Atmel Corporation or its subsidiaries. Other terms and product names may be registered trademarks or trademarks of others.