



Applications

- Intermediate Bus architectures
- Telecommunications equipment
- LAN/WAN
- Data processing

Features

- Cost-effective, single board design
- Low profile – 11 mm height
- Input/output isolation: 1500VDC
- Basic insulation
- High efficiency up to 91%
- Start-up into high capacitive load
- Low conducted and radiated EMI
- Output overcurrent protection
- Output overvoltage protection
- Backdrive protection
- Overtemperature protection
- Remote sense
- Remote on/off (primary referenced), positive or negative logic
- Adjustable output voltage from 9.6V to 13.2V
- UL 1950 Recognition, CSA 22.2 No. 950-95 certification, TUV IEC950

Description

The QBC Series of high density bus converters convert a worldwide telecom bus voltage of 36 to 75VDC to a 12V bus at 11A. The output is ideal for powering non-isolated, point-of-load converters such as synchronous buck converters used commonly in Intermediate Bus Architectures.

The QBC is a highly efficient, cost-effective, low profile, single-output DC/DC converter in an industry-standard, quarter-brick footprint. The standard feature set includes remote on/off, remote output voltage sensing, positive output trim, input undervoltage lockout, and overtemperature shutdown with hysteresis.

Model Selection						
Model	Input Voltage VDC	Input Current, Max ADC	Output Voltage Vout, VDC	Output Rated Current I _{rated} , ADC	Output Ripple/Noise, mV p-p (Typical)	Typical Efficiency @ I _{rated} , %
QBC11ZH-T	36-75	4.5	12.0	11	125	90
This product is intended for integration into end-use equipment. All the required procedures for CE marking of end-use equipment should be followed.						

Absolute Maximum Ratings

Stresses in excess of the absolute maximum ratings may cause performance degradation, adversely effect long-term reliability, and cause permanent damage to the converter.

Parameter	Conditions/Description	Min	Max	Units
Input Voltage	Continuous		75	VDC
	Transient, 100 ms		100	VDC
Operating Temperature	PC Board Temperature	-40	100	°C
Storage Temperature		-40	125	°C

Environmental and Mechanical Specifications

All specifications apply over specified input voltage, output load, and temperature range, unless otherwise noted.

Parameter	Conditions/Description	Min	Nom	Max	Units
Shock	(Half-sinewave, 6ms), 3 axes		50		g
Sinusoidal Vibration	GR-63-CORE, Section 5.4.2		1		g
Weight			1.2/35		Oz/g
Water Washing	Standard process		Yes		
MTBF	Per Bellcore TR-NWT-000332		1,980		kHrs

Isolation Specifications

All specifications apply over specified input voltage, output load, and temperature range, unless otherwise noted.

Parameter	Conditions/Description	Min	Nom	Max	Units
Insulation Safety Rating		Basic			
Isolation Voltage	Input to Output	1500			VDC
Isolation Resistance		10			MOhm
Isolation Capacitance			1000		pF

Input Specifications

All specifications apply over specified input voltage, output load, and temperature range, unless otherwise noted.

Parameter	Conditions/Description	Min	Nom	Max	Units
Input Voltage	Continuous	36	48	75	VDC
Turn-On Input Voltage	Ramping Up	33		35	VDC
Turn-Off Input Voltage	Ramping Down	31		33	VDC
Turn-On Time	To Output Regulation Band 100% Resistive Load		5	10	ms
Input Reflected Ripple Current	Full Load, 12μH source inductance			100	mA p-p
Inrush Transient	Vin=Vin.max			1	A ² s

Output Specifications

All specifications apply over specified input voltage, output load, and temperature range, unless otherwise noted.

Parameter	Conditions/Description	Min	Nom	Max	Units
Output Voltage Setpoint Accuracy	Vin=Vin.nom, Full Load	-2		2	%Vout
Output Current*	See selection chart for I _{rated}	0		100	%I _{rated}
Line Regulation	Vin.min to Vin.max, I _{rated}		0.5	1	%Vout
Load Regulation	Vin=Vin.nom, 10% to 100%I _{rated}		0.5	1	%Vout
Total Output Voltage Regulation	Over all input voltage, load, and temperature conditions	-5		5	%Vout
Remote Sense Headroom				5	%Vout
Dynamic Regulation	50-100% load step change				
Peak Deviation			600		mV
Settling Time	to 2% error band		200	500	μs
Admissible Load Capacitance	I _{rated} , Nom Vin			6,800	μF
Output Current Limit Threshold**	Vout≤0.97Vout.nom	115		135	%I _{rated}
Switching Frequency			425		kHz
Overvoltage Protection, Non Latching	Over all input voltage and load conditions	115		130	%Vout
Trim Range	I _{rated} , Vin=Vnom	80		110	%Vout

* At I_{out}<10% I_{out}, the output may contain low frequency component that exceeds ripple specifications.

** Overcurrent protection is non-latching with auto recovery.

Feature Specifications

All specifications apply over specified input voltage, output load, and temperature range, unless otherwise noted.

Parameter	Conditions/Description	Min	Nom	Max	Units
Shutdown (ON/OFF)					
Negative Logic	On/Off signal is low – converter is ON				
Converter ON		-0.7		0.8	VDC
Source Current	ON/OFF pin is connected to -Vin			1	mADC
Converter OFF		2.5		28	VDC
Positive Logic	On/Off signal is low–converter is OFF				
Converter ON		2.5		28	VDC
Open Circuit Voltage	ON/OFF pin is floating			5	VDC
Converter OFF		-0.7		0.8	VDC
Overtemperature Protection	Average board temperature		125		°C

Characteristic Curves

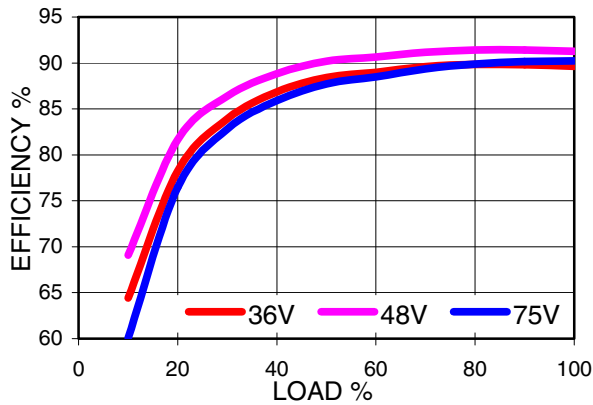

Figure 1. QBC11ZH-T Efficiency vs. Output Load

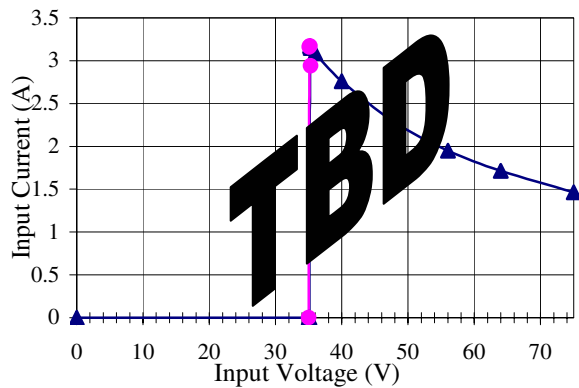

Figure 2. QBC11ZH-T Input Characteristics

Typical Application

Figure 3 shows the recommended connections for the QBC11ZH-T converter.

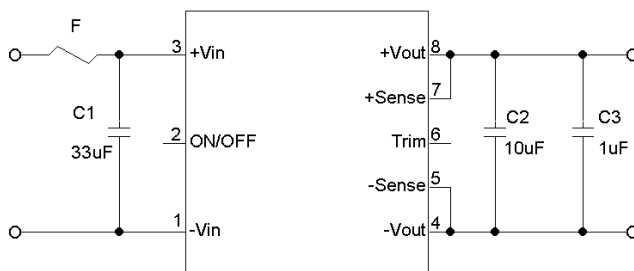

Figure 3. Typical Application of QBC11ZH-T

The QBC11ZH-T converter does not require any external components for proper operation. However, if the distribution of the input voltage to the converter contains significant inductance, the capacitor C1 may be required to enhance performance of the converter. A minimum of a 33 μ F electrolytic capacitor with the ESR<0.7 Ω is recommended for the QBC11ZH-T.

Refer to the “Inrush Current Control Application Note” on www.power-one.com for suggestions on how to limit the magnitude of the inrush current.

For output decoupling we recommend to use a 10 μ F low ESR tantalum (AVX TPSC106M025R0500 is used in our test setup) and a 1 μ F ceramic capacitors. Note, that the capacitors do not substitute the filtering required by the load.

Shutdown Feature Description

The ON/OFF pin in the QBC11ZH-T converter functions as a normal soft shutdown. It is referenced to the -Vin pin (see Figure 3). With the positive logic, when the ON/OFF pin is pulled low, the output is turned off and the unit goes into a very low input power mode.

With negative logic, when the ON/OFF pin is pulled low, the unit is turned on.

An open collector switch is recommended to control the voltage between the ON/OFF pin and the -Vin pin of the converter. The ON/OFF pin is pulled up internally, so no external voltage source is required. The user should avoid connecting a resistor between the ON/OFF pin and the +Vin pin.

When the ON/OFF pin is used to achieve remote control, the user must take care to insure that the pin reference for the control is really the -Vin pin. The control signal must not be referenced ahead of EMI filtering, or remotely from the unit. Optically coupling the information and locating the optical coupler directly at the module will solve any of these problems.

Note:

If the ON/OFF pin is not used, it can be left floating (positive logic), or connected to the -Vin pin (negative logic).

Output Voltage Trim

The trim feature allows the user to adjust the output voltage from the nominal. This can be used to accommodate a different requirement or to do production margin testing.

Industry Standard Trim (suffix -T)

The -T option units trim up with a resistor from the Trim (#6) pin to the +Sense (#7) pin and trim down with a resistor from the Trim (#6) pin to the -Sense (#5) pin as shown in the Figure 4.

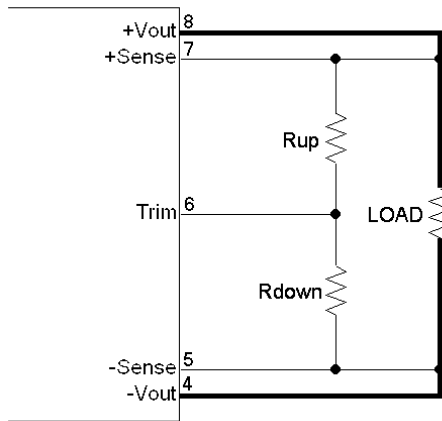

Figure 4. QBC11ZH-T Trim Schematic

The equations below determine the trim resistor value required to achieve a ΔV change in the output voltage.

$$R_{UP} = 5.11 \left(\frac{V_{out}(100 + \Delta V\%)}{1.225\Delta V\%} - \frac{100 + 2\Delta V\%}{\Delta V\%} \right), \text{ k}\Omega$$

$$R_{DOWN} = 5.11 \left(\frac{100}{\Delta V\%} - 10.22 \right), \text{ k}\Omega$$

Where $\Delta V\%$ is the output voltage change expressed in percents of the nominal output voltage, V_{out} .

Notes:

1. When the output voltage is trimmed up, the output power from the converter must not exceed its maximum rating. The power is determined by measuring the output voltage on the output pins, and multiplying it by the output current.
2. In order to avoid creating apparent load regulation degradation, it is important that the trim resistors are connected directly to the remote sense pins, and not to the load or to traces going to the load.
3. The output voltage increase can be accomplished by either the trim or by the remote sense or by a combination of both. In any case the absolute maximum output voltage increase shall not exceed 10% of the nominal output voltage

Safety Considerations

The QBC11ZH-T converter features 1500 Volt DC isolation from input to output. The input to output resistance is greater than 10M Ω . This converter is provided with basic insulation between input and output circuits according to all IEC60950 based standards. Nevertheless, if the system using the converter needs to receive safety agency approval, certain rules must be followed in the design of the system. In particular, all of the creepage and clearance requirements of the end-use safety requirements must be observed. These documents include UL60950 - CSA60950-00 and EN60950, although other or additional requirements may be needed for specific applications.

The QBC11ZH-T converter has no internal fuse. The external fuse must be provided to protect the system from catastrophic failure as shown in Figure 3. The fuse with a rating not greater than 6A is recommended. The user can select a lower rating fuse based upon the highest inrush transient at the maximum input voltage and the maximum input current of the converter, which occurs at the minimum input voltage. Both input traces and the chassis ground trace (if applicable) must be capable of conducting a current of 1.5 times the value of the fuse without opening. The fuse must not be placed in the grounded input line, if any.

In order for the output of the QBC11ZH-T converter to be considered as SELV (Safety Extra Low Voltage) or TNV-1, according to all IEC60950 based standards, one of the following requirements must be met in the system design:

- If the voltage source feeding the module is SELV or TNV-2, the output of the converter may be grounded or ungrounded.
- If the voltage source feeding the module is ELV, the output of the converter may be considered SELV only if the output is grounded per the requirements of the standard.
- If the voltage source feeding the module is a Hazardous Voltage Secondary Circuit, the voltage source feeding the module must be provided with at least Basic insulation between the source to the converter and any hazardous voltages. The entire system, including the QBC11ZH-T converter, must pass a dielectric withstand test for Reinforced insulation. Design of this type of systems requires expert engineering and understanding of the overall safety requirements and should be performed by qualified personnel.

Thermal Considerations

The QBC11ZH-T converter is designed for natural or forced convection cooling. The maximum allowable output current of the converter is determined by meeting the derating criteria for all components used in the converter. For example, the maximum semiconductor junction temperature is not allowed to exceed 125°C to ensure reliable long-term operation

of the converter. Contact Power-One for the complete list of the derating criteria.

The graphs in Figure 5 show the maximum output current of the QBC11ZH-T converter at different ambient temperatures under both natural and forced (transverse airflow direction, from pin 1 to pin 3) convection.

For example, the QBC11ZH-T operating at 50°C can deliver up to 8.8A reliably with 200LFM forced air.

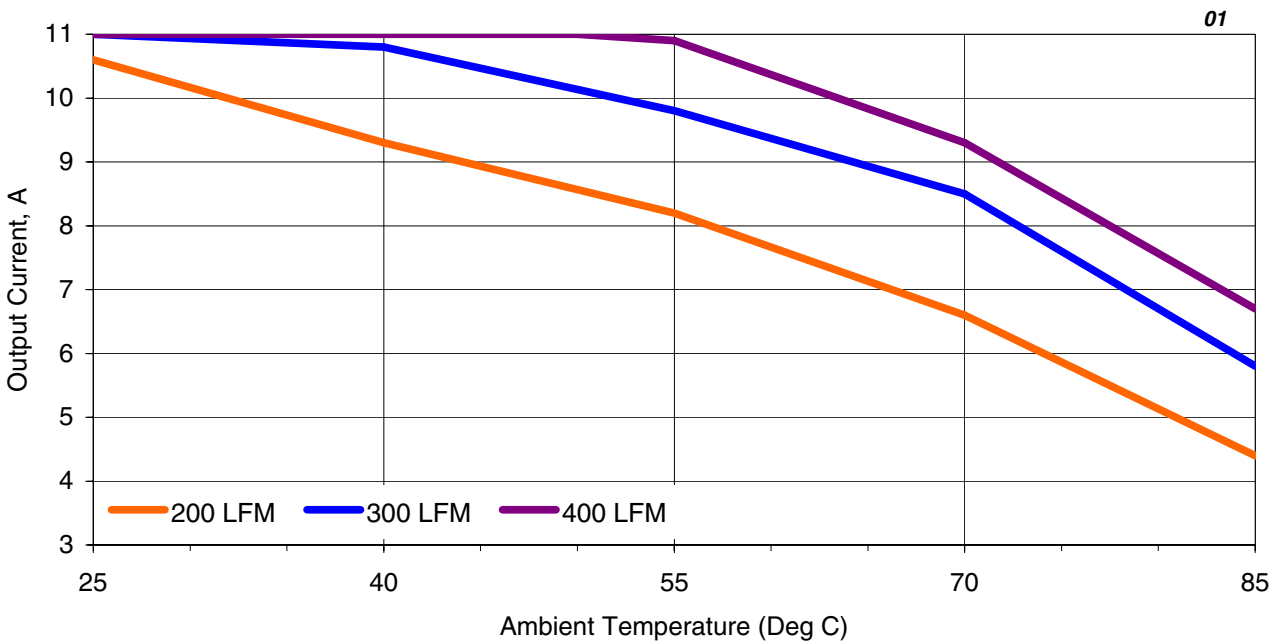
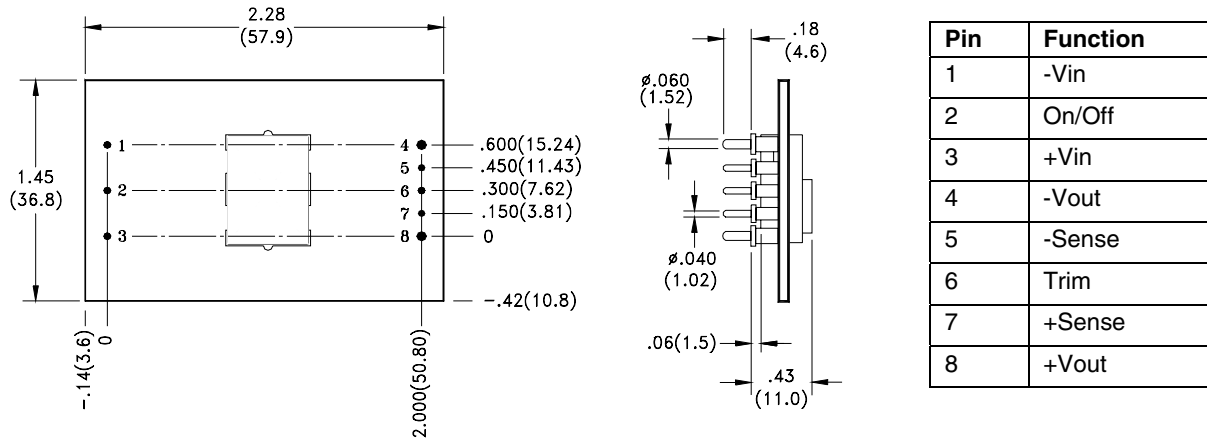

Figure 5. QBC11ZH-T Derating Curves

Mechanical Drawing



Tolerances: .xx ± .020 (.5)
.xxx ± .010 (.25)
Pin Diameter ± 0.002 (.05)

Ordering Information

Options	Suffixes to add to part number
Remote ON/OFF	Negative- Add "NT" suffix
Pin Length	0.18"- Standard, no suffix required
	0.145"- Add "7" suffix
	0.110"- Add "8" suffix

Notes

1. Consult factory for the complete list of available options.

NUCLEAR AND MEDICAL APPLICATIONS - Power-One products are not authorized for use as critical components in life support systems, equipment used in hazardous environments, or nuclear control systems without the express written consent of the respective divisional president of Power-One, Inc.

TECHNICAL REVISIONS - The appearance of products, including safety agency certifications pictured on labels, may change depending on the date manufactured. Specifications are subject to change without notice.