

**FineAdjust
Applicator**

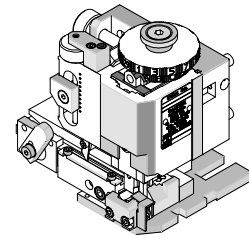

**Application Tooling
Specification Sheet**



Order No. 63867-3000

FEATURES

- Quick punch removal with the push of a button for fast and easy tooling change
- Applicator designed to industry standard mounting and shut height 135.80mm (5.346")
- Quick set-up time; plus the crimp height, track and feed adjustments can be set without removing the applicator from the press
- Fine adjustment allows users to achieve target with little effort by adjusting in increments of 0.15mm (.0006") for conductor crimp height and .063mm (.0025") for insulation height
- Independent adjustment rings allow users to quickly adjust the conductor or insulation crimp height without affecting each other
- Directly adapts to most automatic wire processing machines

SCOPE

Products: 2.54mm (.100") Pitch MX64™ Terminal, 18-20 AWG and 0.75mm² wire.

Terminal Series No.	Terminal Order No.	Wire Size		Insulation Diameter		Strip Length (Ref)	
		AWG	mm ²	mm	In.	mm	In.
33467	33467-0006	18	0.83	1.91-2.06	.075-.081	4.20	.165
33468	33468-0004	Metric Only	0.75	1.70-1.90	.067-.075	4.20	.165
34736	34736-1002	20	0.58	1.70-1.85	.067-.073	4.20	.165

Terminal will accommodate the following wire specification:
SAE: ESB-M1L123-A, WSS-M1L135-A1, and SAE-J1128 Metric: WSK-M1L126-A1.

DEFINITION OF TERMS

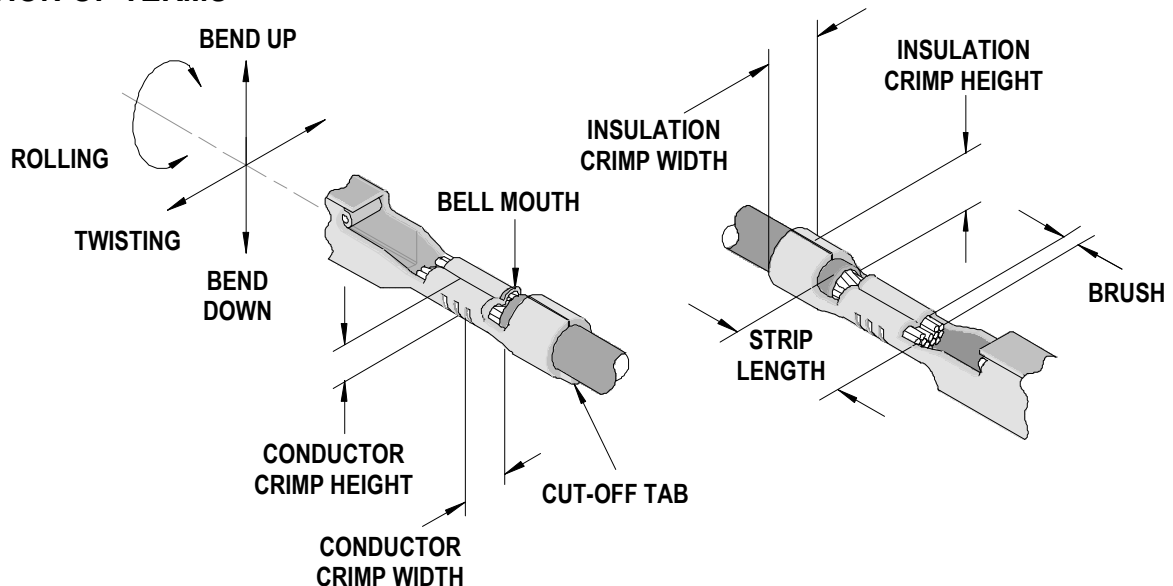

CRIMP SPECIFICATION

Terminal Series No.	Bell mouth		Cut-off Tab Max.		Conductor Brush	
	mm	In.	mm	In.	mm	In.
33467	0.25-1.25	.010-.049	0.50	.020	0.10-0.55	.004-.022
33468						
34736						

Terminal Series No.	Bend up Bend down	Twist	Roll	Seam
33467	Crimped Samples must pass thru the 63867-3008 Checking Aid *			Seam shall not be open and no wire allowed out of the crimping area
33468				
34736				

* Ordered separately

After crimping, the conductor profile should measure the following.

Terminal Series No.	Wire Size		Conductor				Insulation				Pull Force Minimum	
			Crimp Height		Crimp Width		Crimp Height		Crimp Width			
	AWG	mm ²	mm	In.	mm	In.	mm	In.	mm	In.	N	Lb.
33467	18	0.83	1.10-1.20	.043-.047	1.75-1.85	.069-.073	2.00-2.20	.079-.087	1.85-2.05	.073-.081	90	20.3
33468	Metric Only	0.75	1.05-1.15	.041-.045	1.75-1.85	.069-.073	2.00-2.20	.079-.087	1.85-2.05	.073-.081	90	20.3
34736	20	0.58	1.05-1.15	.041-.045	1.75-1.85	.069-.073	1.85-2.05	.073-.081	1.85-2.05	.073-.081	75	17.0

Pull Force should be measured with no influence from the insulation crimp. The above specifications are guidelines to an optimum crimp.

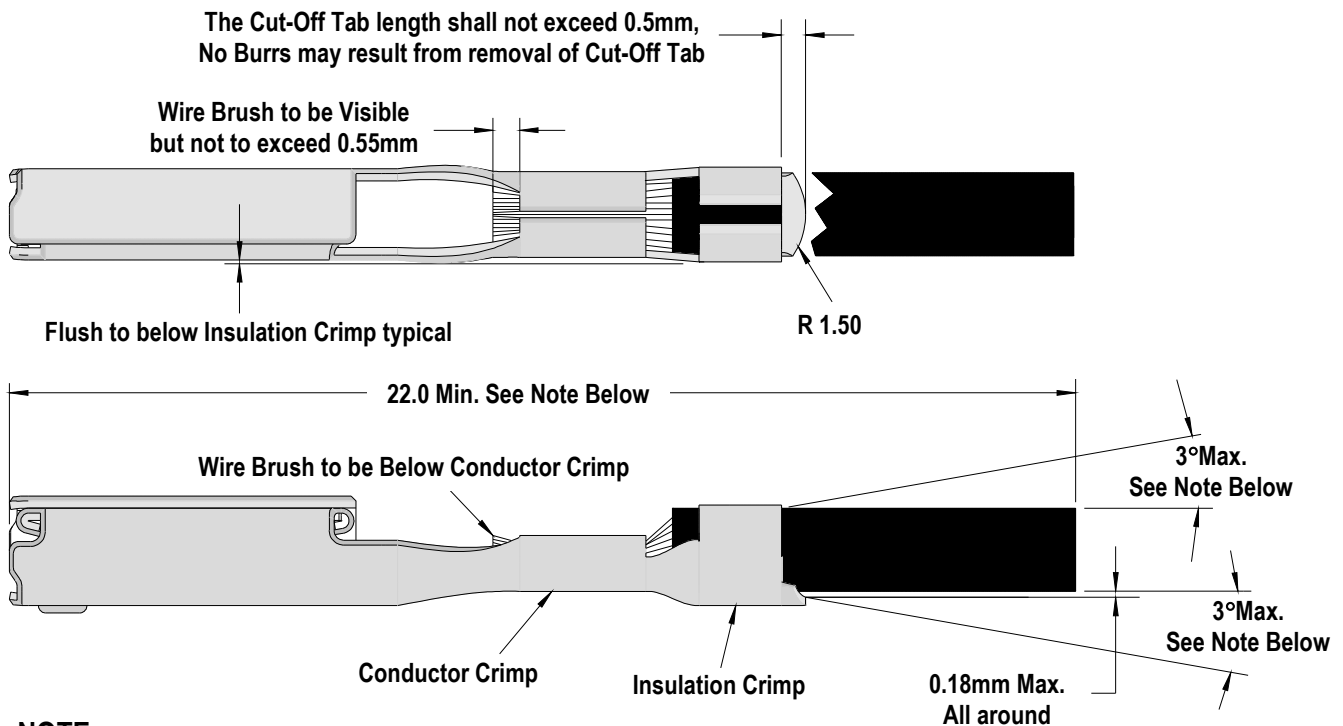

NOTE:

Straightness:

- A Crimped terminal lead must be able to pass freely through the **Checking Aid *, Part No.63867-3008.**
- B Wire on the crimped lead must meet all specification above.

PARTS LIST

FineAdjust Applicator 63867-3000				
Item	Order No	Engineering No.	Description	Quantity
Perishable Tooling				
	63867-3070	63867-3070	Tool Kit (All "Y" Items)	REF
1	63457-1804	63457-1804	Conductor Punch	1 Y
2	63867-3002	63867-3002	Conductor Anvil	1 Y
3	63454-1905	63454-1905	Insulation Punch	1 Y
4	63867-3004	63867-3004	Insulation Anvil	1 Y
5	63867-3005	63867-3005	Cut-Off Plunger	1 Y
6	63443-0036	63443-0036	Front Plunger Retainer	1 Y
Other Components				
7	11-18-4083	60707-8	Feed Guide	1
8	63443-0009	63443-0009	Scrap Chute	1
9	63443-0021	63443-0021	Key	1
10	63443-0090	63443-0090	Wire Stop	1
11	63443-3160	63443-3160	Front Plunger Striker	1
12	63443-6117	63443-6117	Rear Cover	1
13	63700-0539	63700-0539	Cut-off Plunger Spring	1
14	63867-3006	63867-3006	Anvil Mount	1
15	63867-3007	63867-3007	Bottom Cap	1
16	63867-3008	63867-3008	★ Checking Aid	REF
Frame				
17	63800-4901	63800-4901	Top	1
18	63801-3281	63801-3281	Base	1
19	63801-4650	63801-4650	Track	1
Hardware				
20	N/A	N/A	M3 by 6 Long SHCS	2**
21	N/A	N/A	M4 by 6 Long SHCS	2**
22	N/A	N/A	M4 by 8 Long SHSS	1**
23	N/A	N/A	M4 by 12 Long BHCS	2**
24	N/A	N/A	M4 by 12 Long SHCS	2**
25	N/A	N/A	M4 by 16 Long SHCS	1**
26	N/A	N/A	M4 by 50 Long SHCS	2**
27	N/A	N/A	M5 by 12 Long SHCS	1**
28	N/A	N/A	3MM by 6 Long Roll Pin	1**
29	N/A	N/A	#10-32 by 3/8" Long Flat Point SSS	1**
30	N/A	N/A	#10-32 Hex Jam Nut	1**

** Available from an industrial supply company such as MSC (1-800-645-7270).

T The Checking Aid 63867-3008 to be ordered separately if required.
 (This item is not included with the Applicator and is shown for Reference purpose only)

Assembly Drawing

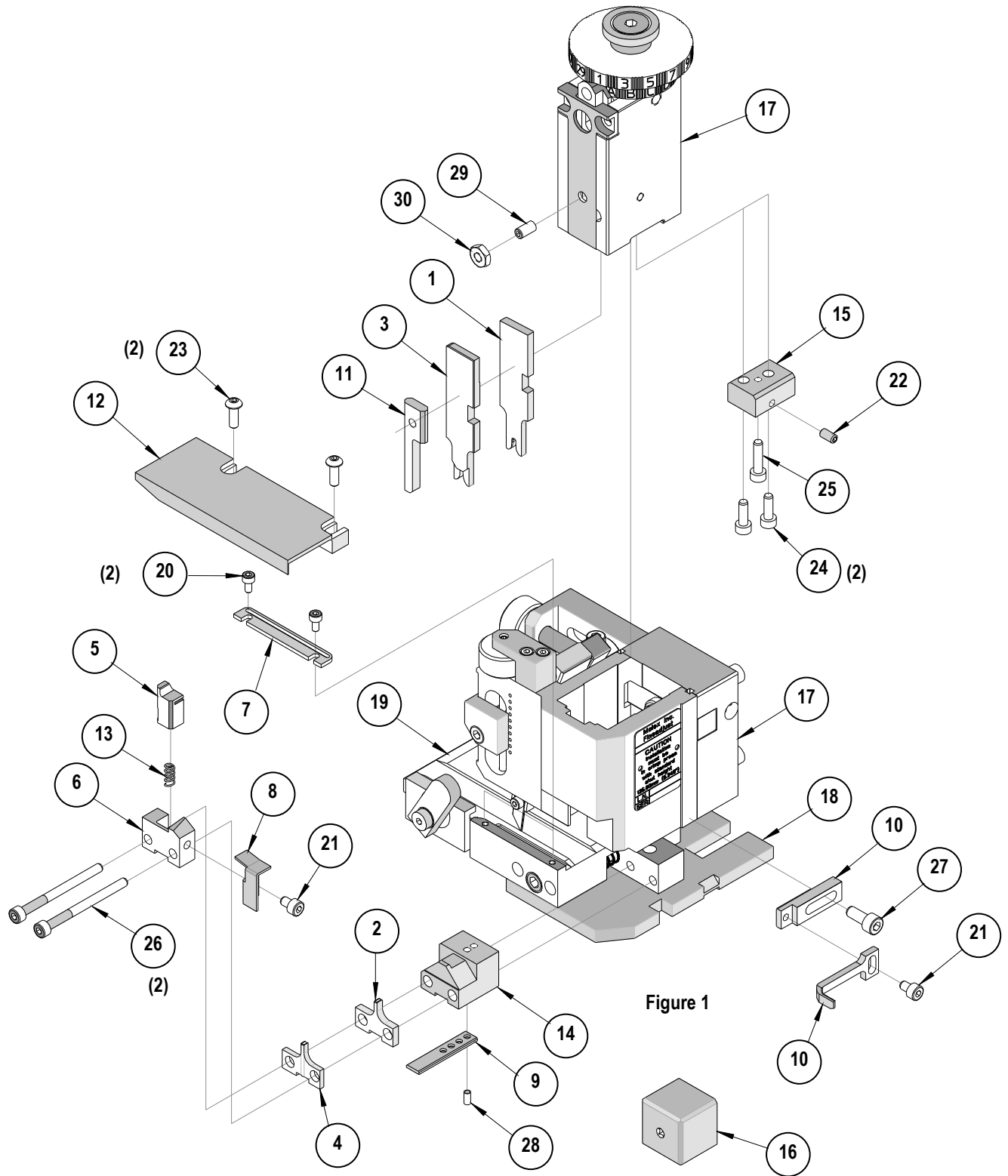

Figure 1

NOTES

1. Molex recommends an extra perishable tooling kit be maintained at your facility.
2. Verify tooling alignment by manually cycling the press and Applicator before crimping under power. Check that all screws are tight.
3. Slugs, Terminals, Dirt and Oil should be kept clear of work area.
4. Wear safety glasses at all times.
5. For recommended maintenance refer to the FineAdjust Manual.

CAUTION: This applicator should only be used in a press with a shut height of 135.80 mm (5.346"). Tooling damage could result at a lower setting.

CAUTION: To prevent injury never operate this Applicator without the guards supplied with the press or wire-processing machine in place. Reference the press or wire processing manufacturer's instruction manual.

CAUTION: Molex crimp specifications are valid only when used with Molex terminals, applicators and tooling.

Visit our Web site at <http://www.molex.com>