

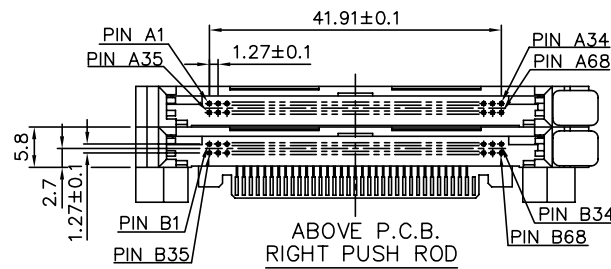

PRODUCT NO.
10022253-250CA
10022253-250CALF

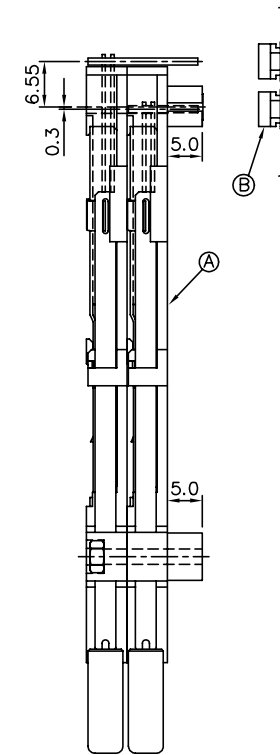
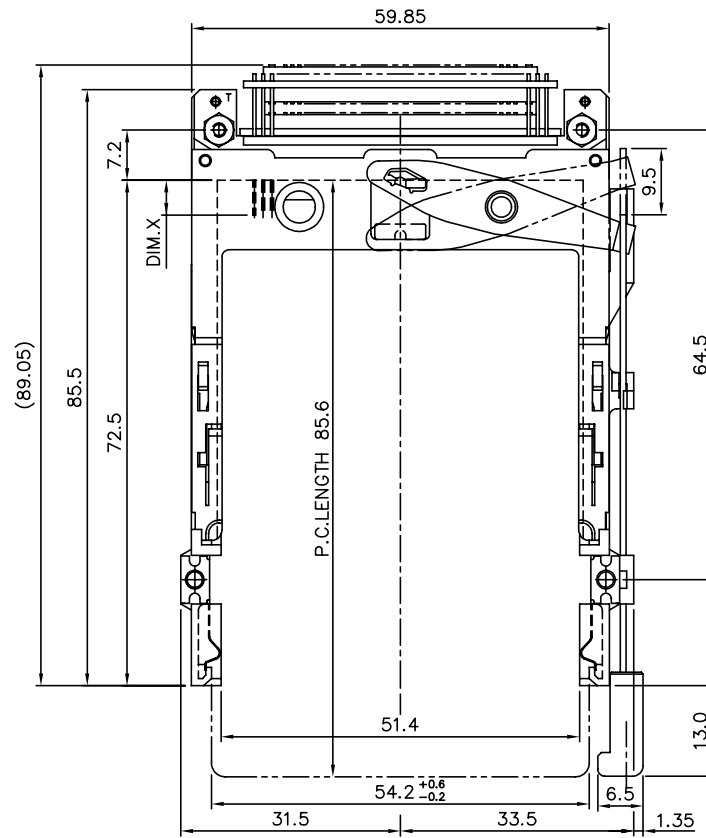

mat'l. code		surface ISO1302 ✓		tolerance ISO1101 ISO406		projection ASME Y14.5		product family PCMCIA	
l t r e c n n o d r		date		tolerances unless otherwise specified		MM		PCMCIA TRANSITION BOARD 3.3V, SMT TYPE 1/2/3	
A	T03-0238	WL	06/20/03	±0.30		scale 1:1		dwg no 10022253 sheet 1 of 2 size A4	
B	N04-0092	WB	12/01/04	angle 0°		FCI		type Product Customer Drawing	
C	BLX-N-011450	ZK	04/10/12	0°±2'					
		dr		WENDY CHEN		01/27/03			
		eng		SPENCER LAI		01/27/03			
		chr		SCOTT LU		01/27/03			
		appd		JENN TSAO		01/27/03			
sheet index	revision	c	c						
	sheet	1	2						

NOTES:

1. 8mm MIN. CARD EJECT.
2. EJECT TRAVEL: 9.5mm
3. PUSH ROD LOCATION AND P.C.B. SIDE ARE AS APPEARS INSTALLED.
4. MATERIAL
 - 4.1 HEADER ASS'Y:
 PLASTIC :HIGH TEMPERATURE THERMOPLASTIC UL94V-0 BLACK
 PIN :COPPER ALLOY
 PCB : FR4
 - 4.2 EJECT MECHANISM ASS'Y:
 PLASTIC :GUIDE:HIGH TEMPERATURE THERMOPLASTIC UL94V-0 BLACK
 :BUTTON:HIGH TEMPERATURE THERMOPLASTIC UL94V-0 BLACK
 PLATE AND PUSH ROD :STAINLESS
 EMI CONTACT:PHOSPHOR BRONZE
5. FINISH (PIN)
 - UNDER PLATING :0.5µm MIN. Ni
 - CONTACT AREA :0.076µm MIN. GOLD
- SOLDER TAIL(TIN LEAD OPTION) : 2.5µm MIN. Sn-Pb
- SOLDER TAIL(LEAD FREE OPTION) : 2.5µm MIN. PURE TIN
6. IF LEAD FREE P/N. THE HOUSING WILL WITHSTAND EXPOSURE TO 260°C PEAK TEMPERATURE FOR 10 SECONDS IN A WAVE SOLDER APPLICATION WITH A 1.00MM MINIMUM THICK CIRCUIT BOARD.
7. LEAD FREE PRODUCT MEETS EUROPEAN UNION DIRECTIVES AND OTHER COUNTRY REGULATIONS AS DISCRIBLED IN GS-22-008
8. IF LEAD FREE P/N. PACKAGING MEETS GS-14-920 SPECIFICATION
9. DIM "X"

4.25±0.1	3.5±0.1	5.0±0.1
OTHERS	36,67	1,17,34,35,51,68

ORDERING INFORMATION		
NAME	PART NO.	Q'TY
(A) EJECT HEADER ASS'Y	10022253-250CA	1
(B) MATING RECEPTACLE	91931-31169	2

NAME	PART NO.	Q'TY
(A) EJECT HEADER ASS'Y	10022253-250CALF	1
(B) MATING RECEPTACLE	91931-31169LF	2

10. PRODUCT SPEC: 110-263

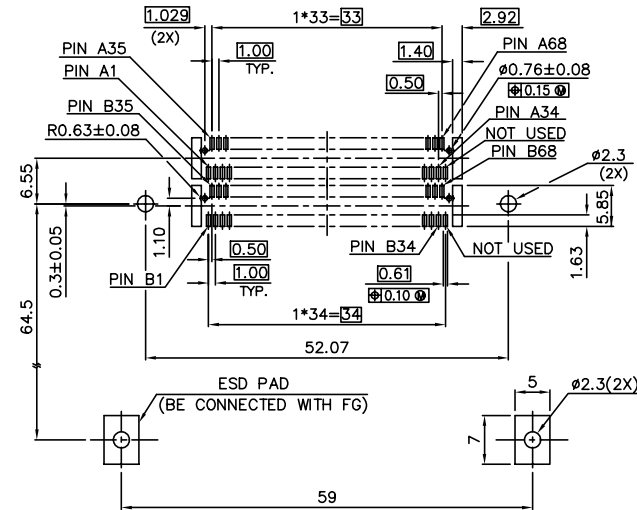

BOARD VIEW FROM CONNECTOR MOUNTED SIDE
TOP OF BOARD IN APPLICATION

mat'l. code	surface ISO1302	tolerance ISO1101 ISO406	projection MM	product family PCMCIA
l t r e c n n o d r	date	tolerances unless otherwise specified	scale 1:1	title PCMCIA TRANSITION BOARD 3.3V, SMT TYPE 1/2/3
c	angle	±0.1	scale 1:1	dwg no 10022253
	dr	WENDY CHEN 01/27/03		sheet 2 of 2
	engr	SPENCER LAI 01/27/03		size A4
	chr	SCOTT LU 01/27/03		type Product Customer Drawing
	appd	JENN TSAO 01/27/03		
sheet index	revision sheet			