

REV.	DESCRIPTION/ECO NO.	DATE
	RELEASE AND CANCEL	2/7/03
	BXA503/KIT & BXA-503/INV	
A	OUTPUT CURRENT TO SINGLE	9/21/06
B	RoHS COMPLIANT RATINGS	4/4/08

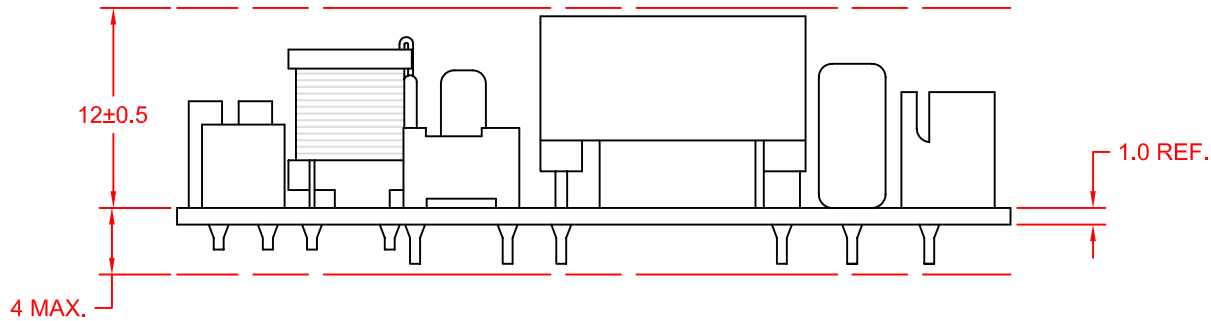
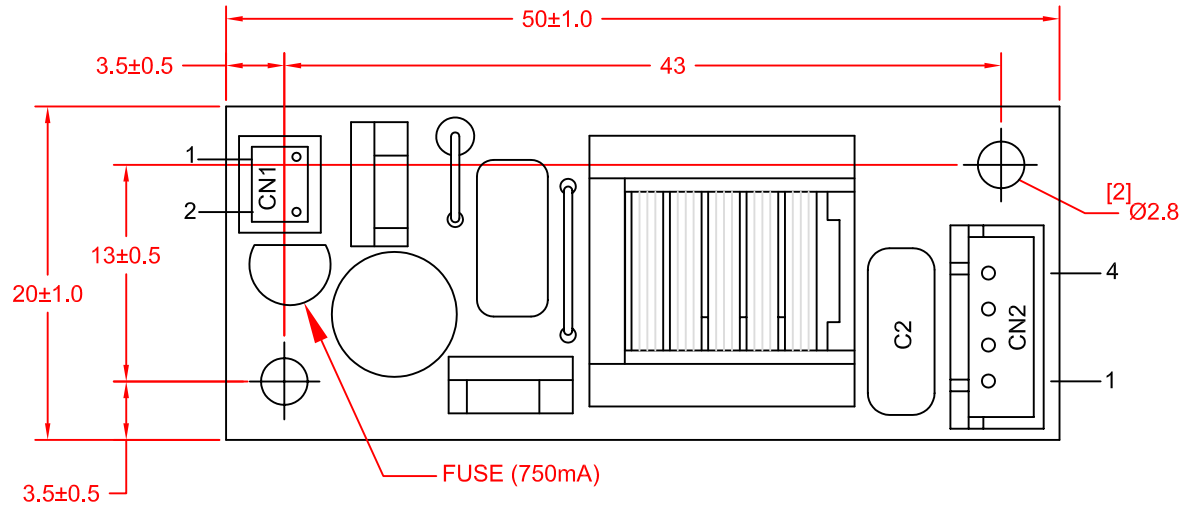

NO.	PIN NUMBER	JKL MATING WIRE HARNESS
CN1	1 INPUT (GND)	BXC-10574
	2 INPUT (+V)	
CN2	1 OUTPUT (HV1)	BXC-10585
	2 NO CONNECTION	
	3	
	4 OUT LAMP (GND)	

OPERATING SPECIFICATIONS

CHARACTERISTICS	MIN	TYP	MAX
INPUT VOLTAGE: (vdc)	4.5	5.0	7.0
INPUT CURRENT: (mA)	390	450	510
OUTPUT VOLTAGE: (Vrms)	-	1000	-
OUTPUT CURRENT: (mA)	4.0	5.0	6.0
OUTPUT FREQUENCY: (kHz)	33	38	43
OPERATING TEMP: (CELSIUS)	0	25	50
STORAGE TEMP: (CELSIUS)	-20	-	70

NOTE:
MATING CONNECTORS ARE NOT INCLUDED WITH INVERTER.
JKL WIRE HARNESS BXC-10574 AND BXC-10585 CAN BE ORDERED SEPARATELY.

RoHS COMPLIANT PRODUCT.

JKL PART NUMBER: BXA-503

METRIC THIRD ANGLE PROJECTION	DIMENSIONS ARE IN MILLIMETERS TOLERANCE UNLESS OTHERWISE SPECIFIED 1 PL +/- 0.3 2 PL +/- ANGLE +/- 0	JKL COMPONENTS CORPORATION			
	TITLE CCFL SINGLE OUTPUT INVERTER				
DRAWN BY L. WENGSTROM	APP'VD BY L.R.	DATE 4/4/08	SIZE A	FSCM NO. 55335	DRAWING NO. BXA-503
- CAD DRAWING - MANUAL REVISIONS NOT PERMITTED			SCALE NONE	RELEASED DATE 2/7/03	REVISION DATE 4/4/08
				REV. NO. B	SHEET OF