

AS1747, AS1748, AS1749, AS1750

Low-Voltage, Dual SPDT, Audio Clickless Switches with Negative Rail Capability

1 General Description

The SPDT (single-pole/double-throw) switches AS1747, AS1748, AS1749 and AS1750 allow signals below ground to pass through without distortion. These analog switches are ideal for switching audio signals, due to their supply voltage from +1.8V to +5.5V and their low 0.4Ω on-resistance.

An included comparator offers the AS1748 and AS1750 with headphone detection or mute/send key function.

To reduce click-and-pop sounds when switching between pre-charged points the AS1749 and AS1750 have an internal shunt switch. This shunt switch automatically discharges any capacitance at the NO and NC connection points.

This SPDT switch is available in space-saving 10-pin TDFN 3x3 packages and operate over the -40°C to +85°C extended temperature range.

2 Key Features

- Distortion -Free Negative Signal Throughput Down to $V_{CC} - 5.5V$
- Comparator for Headphone or Mute Detection (AS1748/AS1750)
- Internal Shunt Resistor Reduces Click/Pop (AS1749/AS1750)
- Low On-Resistance (R_{ON})
0.4Ω at +2.7V Supply
- 0.25Ω On-Resistance Flatness
- 0.03Ω On-Resistance Matching
- +1.8V to +5.5V Supply Voltage
- -90dB Crosstalk (100kHz)
- -65dB Off-Isolation (100kHz)
- 0.01% Total Harmonic Distortion
- Available in 10-pin TDFN 3x3, 16-pin TQFN 3x3, and 12-Bump WL-CSP Packages

3 Applications

The device is ideal for cell phones, PDAs and hand-held devices, notebook computers and MP3 players.

Figure 1. Typical Operating Circuit

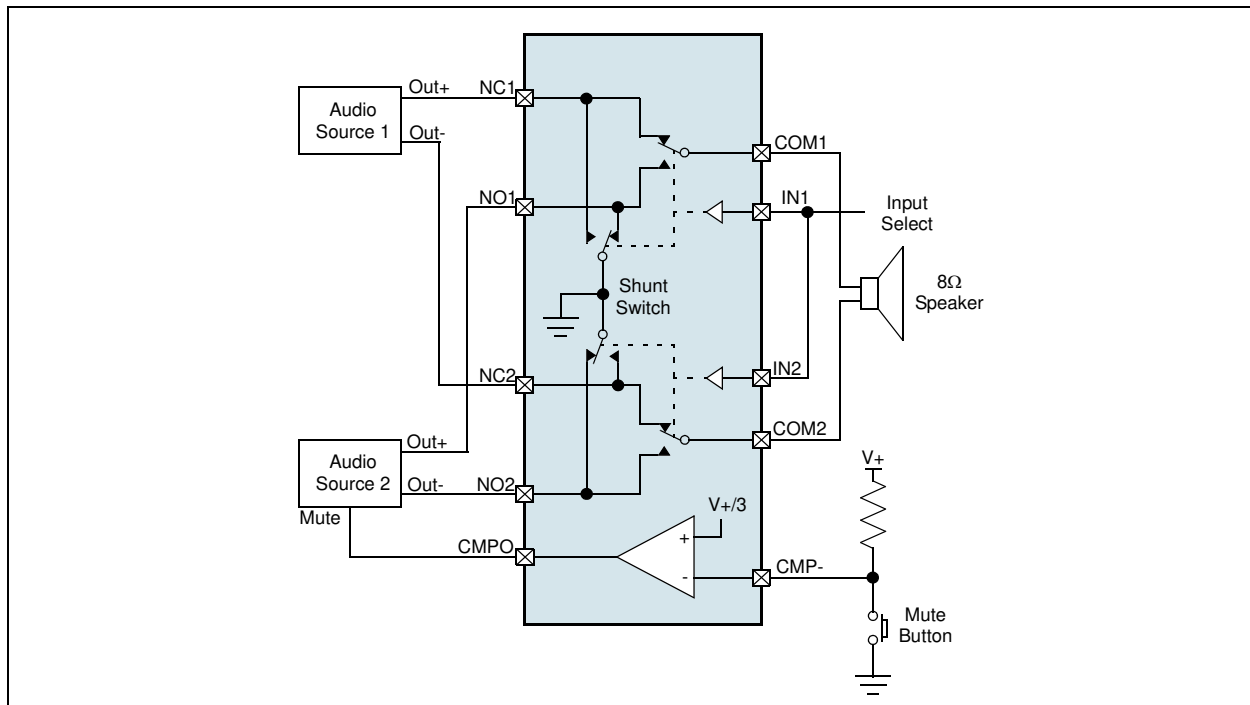

4 Pinout

Pin Assignment

Figure 2. Pin Assignments (Top View) for AS1747/AS1749

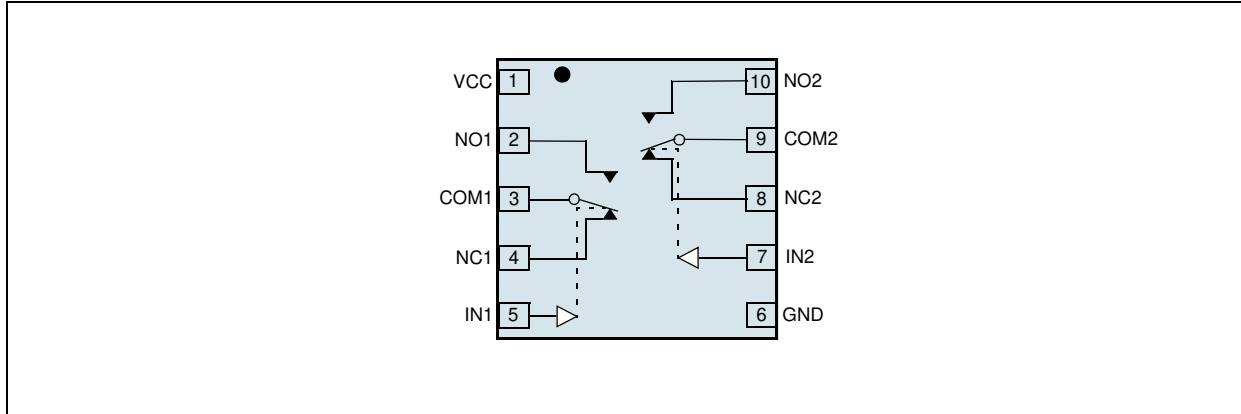

Pin Description

Table 1. Pin Description for AS1747/AS1749

Pin Name	TDFN	Description
Vcc	1	Positive-Supply Voltage Input
NO1	2	Analog Switch 1 - Normally Open Terminal
COM1	3	Analog Switch 1 - Common Terminal
NC1	4	Analog Switch 1 - Normally Closed Terminal
IN1	5	Digital Control Input for Analog Switch 1. A logic LOW on IN1 connects COM1 to NC1 and a logic HIGH connects COM1 to NO1.
GND	6	Ground
IN2	7	Digital Control Input for Analog Switch 2. A logic LOW on IN2 connects COM2 to NC2 and a logic HIGH connects COM2 to NO2.
NC2	8	Analog Switch 2 - Normally Closed Terminal
COM2	9	Analog Switch 2 - Common Terminal
NO2	10	Analog Switch 2 - Normally Open Terminal
EP	EP (TDFN only)	Exposed pad for TDFN package. Connect to GND.

Pin Assignment

Figure 3. Pin Assignments (Top View) for AS1748/AS1750

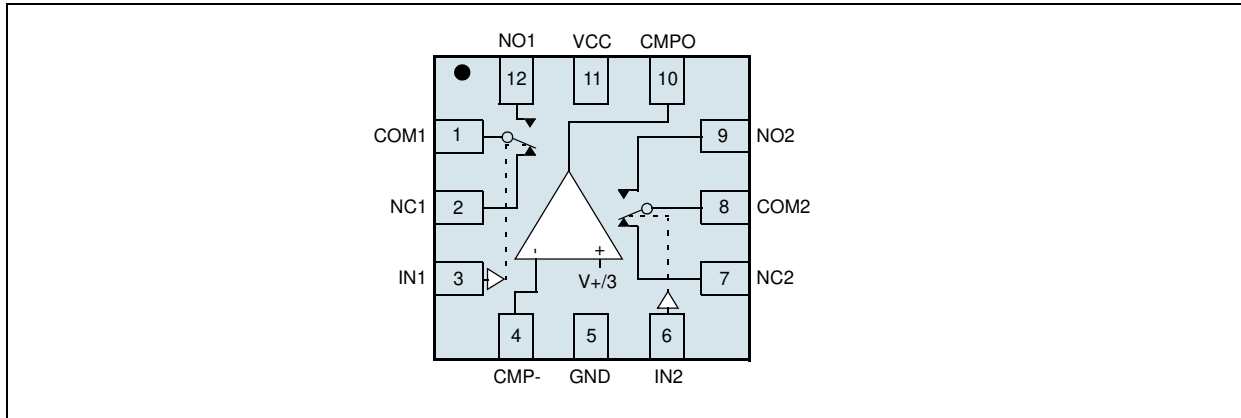

Pin Description

Table 2. Pin Description for AS1748/AS1750

Pin Name	TQFN	Description
COM1	1	Analog Switch 1 - Common Terminal
NC1	2	Analog Switch 1 - Normally Closed Terminal
IN1	3	Digital Control Input for Analog Switch 1. A logic LOW on IN1 connects COM1 to NC1 and a logic HIGH connects COM1 to NO1.
CMP-	4	Comparator Inverting Input
GND	5	Ground
IN2	6	Digital Control Input for Analog Switch 2. A logic LOW on IN2 connects COM2 to NC2 and a logic HIGH connects COM2 to NO2.
NC2	7	Analog Switch 2 - Normally Closed Terminal
COM2	8	Analog Switch 2 - Common Terminal
NO2	9	Analog Switch 2 - Normally Open Terminal
CMPO	10	Comparator Output
Vcc	11	Positive-Supply Voltage Input
NO1	12	Analog Switch 1 - Normally Open Terminal
EP	EP	Exposed pad. Connect to GND.

5 Absolute Maximum Ratings

Stresses beyond those listed in [Table 3](#) may cause permanent damage to the device. These are stress ratings only, and functional operation of the device at these or any other conditions beyond those indicated in [Electrical Characteristics on page 5](#) is not implied. Exposure to absolute maximum rating conditions for extended periods may affect device reliability.

Table 3. Absolute Maximum Ratings

Parameter	Min	Max	Units	Comments
V _{CC} , IN ₋ , CMP-	-0.3	+6.0	V	
COM ₋ , NO ₋ , NC ₋	V _{CC} - 6	V _{CC} + 0.3	V	
CMPO	0.3	V _{CC} + 0.3	V	
Closed-Switch Continuous Current COM ₋ , NO ₋ , NC ₋		±150	mA	
Open-Switch Continuous Current NO ₋ , NC ₋ (AS1749/AS1750)		±30	mA	
Peak Current COM ₋ , NO ₋ , NC ₋ (pulsed at 1ms, 10% duty cycle)		±400	mA	
Continuous Power Dissipation (T_A = +70°C)				
10-pin TDFN 3x3 (derate 24.4mW/°C above +70°C)		1951	mW	
12-Bump WL-CSP (AS1747/AS1749) (derate 5.6mW/°C above +70°C)		449	mW	
12-Bump WL-CSP (AS1748/AS1750) (derate 6.5mW/°C above +70°C)		519	mW	
16-pin TQFN 3x3 (derate 16.9mW/°C above +70°C)		1349	mW	
ESD		2	kV	HBM MIL-Std. 883E 3015.7 methods
Latchup Immunity	-200	+200	mA	@25°C, JEDEC 78
Operating Temperature Range	-40	+85	°C	
Junction Temperature		+150	°C	
Storage Temperature Range	-65	+150	°C	
Package Body Temperature		+260	°C	The reflow peak soldering temperature (body temperature) specified is in accordance with IPC/JEDEC J-STD-020D "Moisture/Reflow Sensitivity Classification for Non-Hermetic Solid State Surface Mount Devices". The lead finish for Pb-free leaded packages is matte tin (100% Sn).

6 Electrical Characteristics

VCC = +2.7V to +5.5V, TA = -40°C to +85°C, unless otherwise specified. Typical values are at VCC = +3.0V, TA = +25°C, unless otherwise specified.

Table 4. Electrical Characteristics

Symbol	Parameter	Condition	Min	Typ	Max	Unit	
Analog Switch							
VNO_ VNC_ VCOM_	Analog Signal Range		VCC - 5.5		VCC	V	
RON(NC) RON(NO)	On-Resistance	VCC = 2.7V; VNC_ or VNO_ = VCC - 5.5V, -1V, 0V, 1V, 2V, VCC; ICOM_ = 100mA	TA = +25°C	0.4	0.85	Ω	
			TA = TMIN to TMAX		0.95		
ΔRON	On-Resistance Match Between Channels	VCC = 2.7V, VNC_ or VNO_ = 0V, ICOM_ = 100mA	TA = +25°C	0.03	0.1	Ω	
			TA = TMIN to TMAX		0.15		
RFLAT(NC)	On-Resistance Flatness	VCC = 2.7V; VNC_ or VNO_ = -1V, 0V, 1V, 2V, VCC; ICOM_ = 100mA	TA = +25°C	0.25	0.4	Ω	
			TA = TMIN to TMAX		0.45		
RSH	Shunt Switch Resistance	AS1749/AS1750 only, INO_ or INC_ = 10mA, VCC = 2.7V	TA = TMIN to TMAX	25	50	Ω	
INO_(OFF) INC_(OFF)	NO_, NC_ Off-Leakage Current	AS1747/AS1748 only, VCC = 2.7V, switch open; VNC_ or VNO_ = -2.5V, +2.5V; VCOM_ = +2.5V, -2.5V	TA = +25°C	-10	+10	nA	
			TA = TMIN to TMAX	-200	+200		
ICOM_(ON)	COM_ On-Leakage Current	VCC = 2.7V, switch closed; VNC_ or VNO_ = -2.5V, +2.5V; or floating; VCOM_ = -2.5V, +2.5V, or floating	TA = +25°C	-10	+10	nA	
			TA = TMIN to TMAX	-200	+200		
Dynamic Characteristics							
tON	Turn-On Time ¹	VNO_ = 2.5V; for NO_, VIN_ = 0V to VCC; for NC_, VIN_ = VCC to 0V; RL = 300Ω, CL = 35pF, Figure 19	TA = +25°C		200	400	ns
			TA = TMIN to TMAX			400	
tOFF	Turn-Off Time ¹	VNC_ = 2.5V; for NO_, VIN_ = VCC to 0V; for NC_, VIN_ = 0V to VCC; RL = 300Ω, CL = 35pF, Figure 19	TA = +25°C		50	200	ns
			TA = TMIN to TMAX			200	
tD	Break-Before-Make Time Delay	VN_ = 2.5V, for NO_, VIN_ = VCC to 0V; for NC_, VIN_ = 0V to VCC; RL = 300Ω, CL = 35pF, Figure 20			200		ns
Q	Charge Injection	VCOM_ = 0V, RS = 0Ω, CL = 1.0nF, Figure 21			2		pC
VISO	Off-Isolation	VCC = 5V, f = 100kHz, VCOM_ = 1VRMS, RL = 50Ω, CL = 5pF, Figure 22			-65		dB
VCT	Crosstalk	VCC = 5V, f = 100kHz, VCOM_ = 1VRMS, RL = 50Ω, CL = 5pF, Figure 22			-90		dB
PSRR	Power-Supply Rejection Ratio	f = 10kHz, VCOM_ = 1VRMS, RL = 50Ω, CL = 5pF			70		dB
BW	On-Channel-3dB Bandwidth	VCC = 5V, Signal = 0dBm, RL = 50Ω, CL = 5pF, Figure 22			31		MHz

Table 4. Electrical Characteristics (Continued)

Symbol	Parameter	Condition	Min	Typ	Max	Unit
THD	Total Harmonic Distortion	$f = 20\text{Hz to } 20\text{kHz}, V_{\text{COM}_-} = 0.5V_{\text{P-P}}, \text{DC Bias} = 0, R_L = 32\Omega$		0.01		%
$C_{\text{NO_Off}}$ $C_{\text{NC_Off}}$	NO ₋ , NC ₋ Off-Capacitance	$f = 1\text{MHz}, V_{\text{COM}_-} = 0.5V_{\text{P-P}}, \text{DC Bias} = 0$		63		pF
$C_{\text{COM_ON}}$	COM On-Capacitance	$f = 1\text{MHz}, V_{\text{COM}_-} = 0.5V_{\text{P-P}}, \text{DC Bias} = 0$		196		pF
Digital I/O (IN₋)						
V_{IH}	Input Logic High Voltage	$V_{\text{CC}} = 2.7\text{V to } 3.6\text{V}$	1.4			V
		$V_{\text{CC}} = 4.2\text{V to } 5.5\text{V}$	2.0			
V_{IL}	Input Logic Low Voltage	$V_{\text{CC}} = 2.7\text{V to } 3.6\text{V}$			0.5	V
		$V_{\text{CC}} = 4.2\text{V to } 5.5\text{V}$			0.8	
I_{IN}	Input Leakage Current	$V_{\text{IN}_-} = 0\text{V to } V_{\text{CC}}, V_{\text{CC}} = 5.5\text{V}$	-1		+1	μA
Comparator (AS1748/AS1750)						
	Comparator Threshold			$V_{\text{CC}}/3$		V
	Comparator Output High Voltage	$I_{\text{SOURCE}} = 1\text{mA}$	$V_{\text{CC}} - 0.45\text{V}$			V
	Comparator Output Low Voltage	$I_{\text{SINK}} = 1\text{mA}$			0.4V	V
	Comparator Input Leakage Current	$V_{\text{CMP}_-} = 0 \text{ to } 2.7\text{V}$	-50		+50	nA
	Comparator Switching Time	$V_{\text{CC}} = 2.7\text{V}, V_{\text{CMP}_-} = 0\text{V to } V_{\text{CC}}, \text{from } 50\% \text{ of } V_{\text{CMP}_-} \text{ to } 50\% \text{ of } V_{\text{CMPO}}$		0.3	0.4	μs
Power Supply						
V_{CC}	Power-Supply Range		1.8		5.5	V
I_{CC}	Supply Current	$V_{\text{CC}} = 5.5\text{V}, V_{\text{IN}_-} = 0\text{V or } V_{\text{CC}}$	AS1747/AS1749	0.01	1	μA
			AS1748/AS1750	5	10	

1. Guaranteed by design

Note: All limits are guaranteed. The parameters with min and max values are guaranteed with production tests or SQC (Statistical Quality Control) methods.

7 Typical Operating Characteristics

VCC = 3.0V, TA = +25°C (unless otherwise specified).

Figure 4. ON-Resistance vs. VCOM

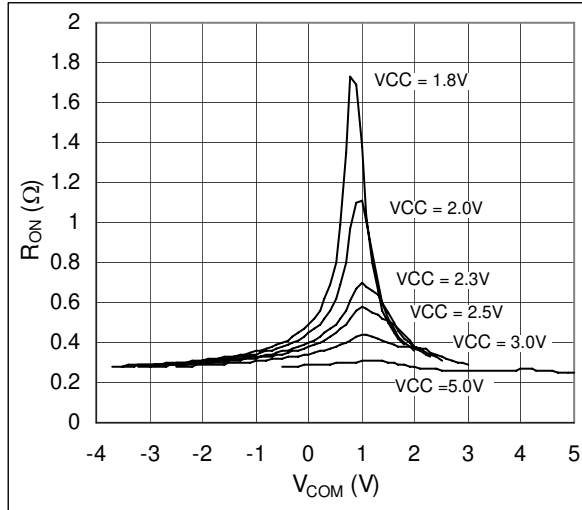

Figure 5. ON Resistance vs. VCOM; VCC=3.0V

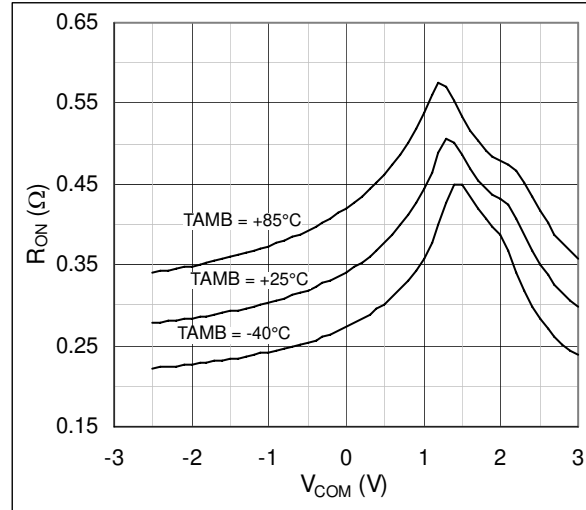

Figure 6. ON Resistance vs. VCOM; VCC=5.0V

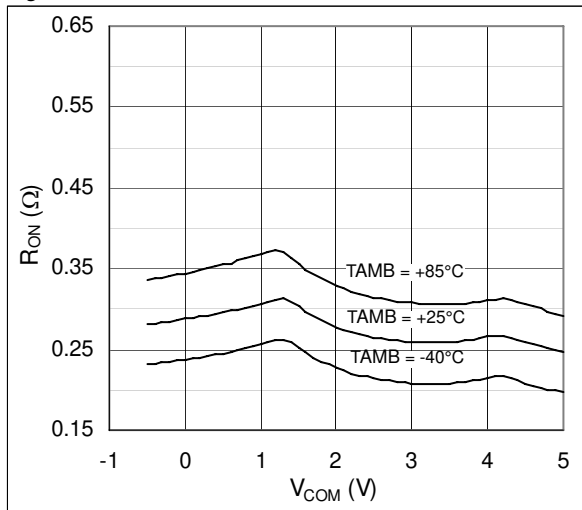

Figure 7. ICC vs. VCC; AS1747/AS1749

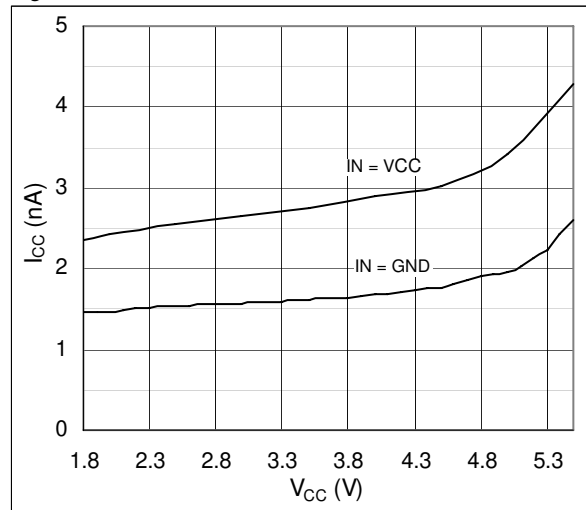

Figure 8. ICC vs. VCC; AS1748/AS1750

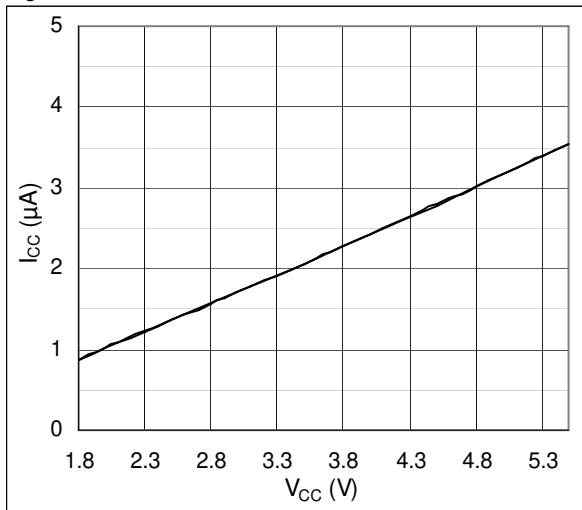

Figure 9. Turn-ON/OFF Times vs. VCC

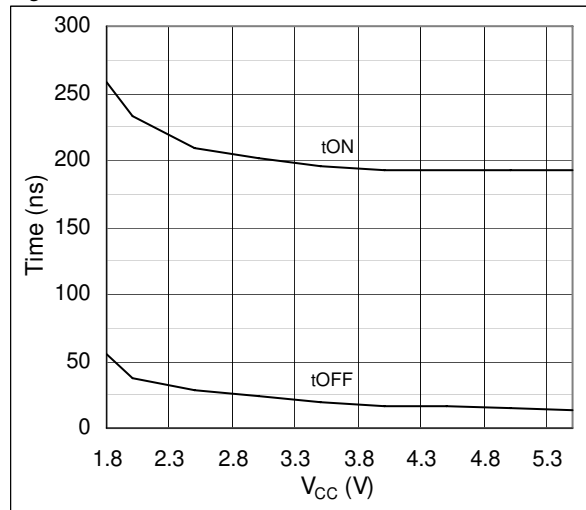

Figure 10. Turn-ON/OFF vs. Temperature; $V_{CC} = 3V$

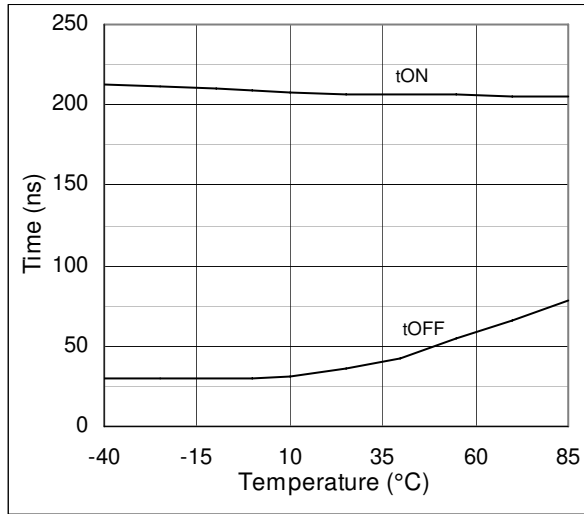

Figure 11. Logic Threshold Voltage vs. V_{CC}

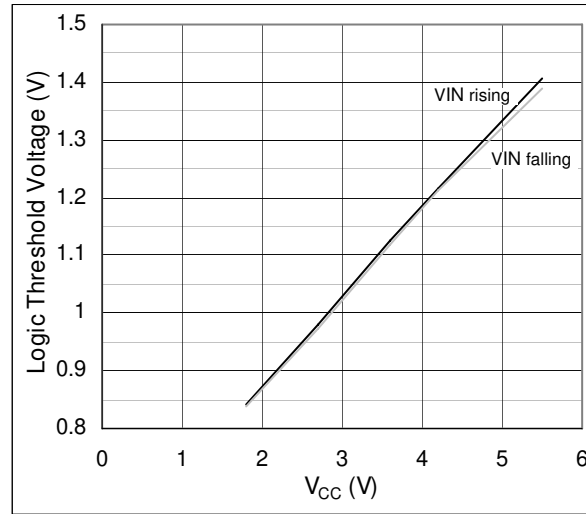

Figure 12. Charge Injection vs. V_{COM} ; $C_{LOAD} = 1nF$

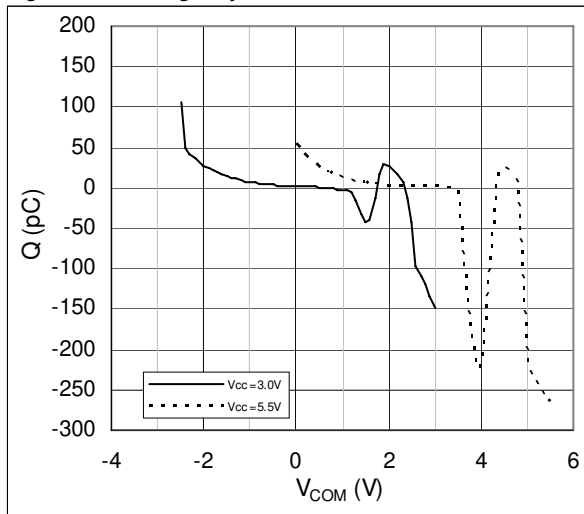

Figure 13. Leakage Current vs. Temperature

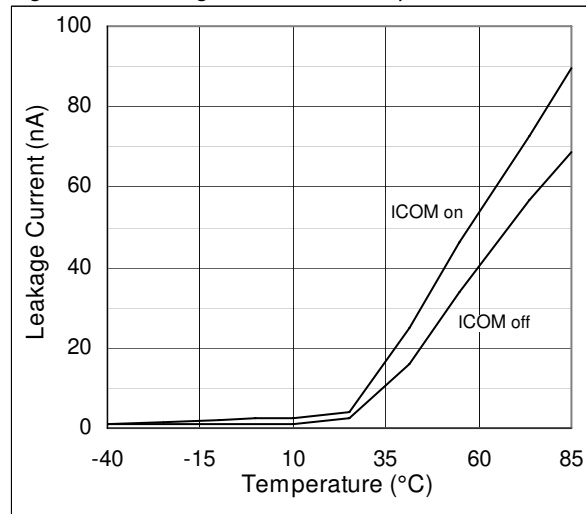

Figure 14. Frequency Response

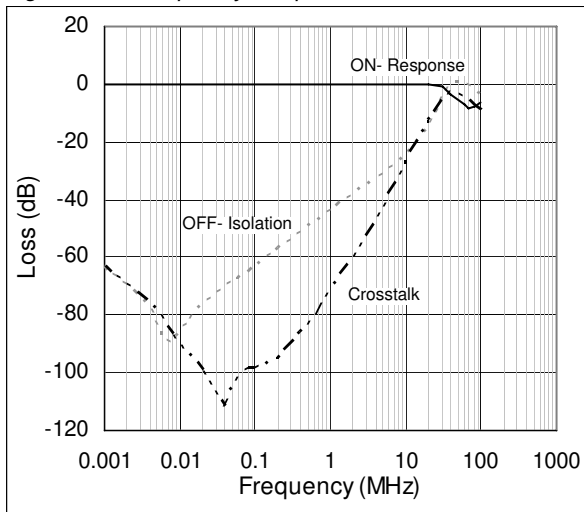

Figure 15. Total Harmonic Distortion vs. Frequency

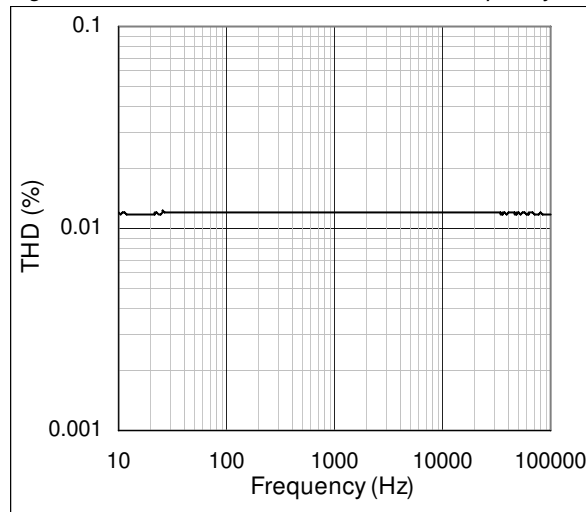

Figure 16. Comparator Threshold vs. Temperature;
V_{CC} = 3.0V

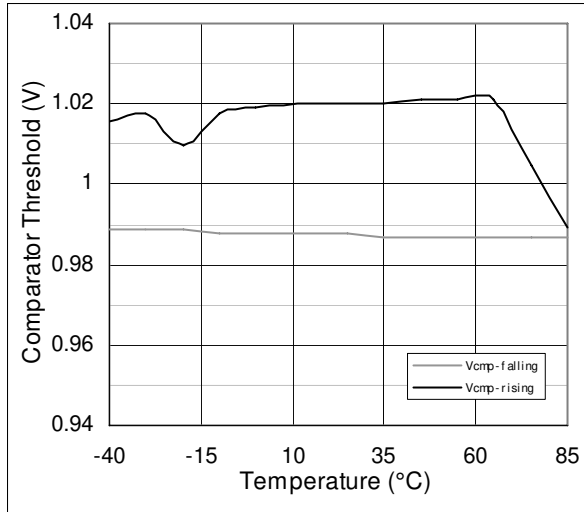

Figure 17. Comparator Threshold vs. Temperature;
V_{CC} = 5.0V

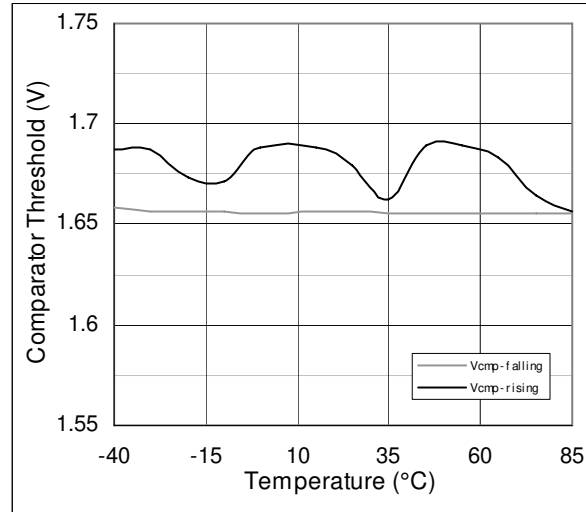
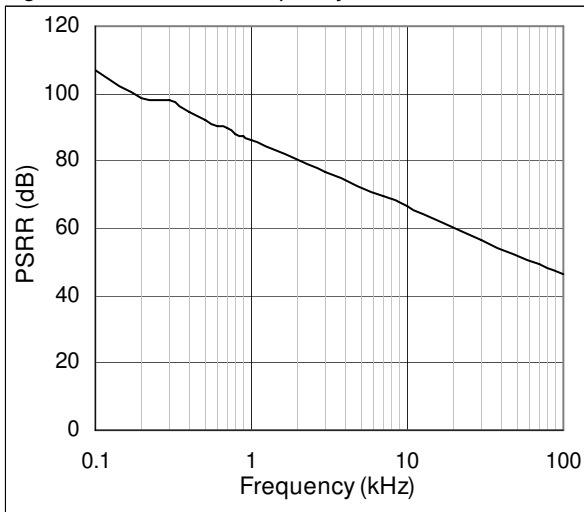

Figure 18. PSRR vs. Frequency



8 Detailed Description

The AS1747– AS1750 are operating from a +1.8V to +5.5V supply and feature a negative signal capability that allows signals below ground to pass through without distortion. A break-before-make switching and a low on-resistance are also included in this analog dual SPDT switches. The device is fully specified for a 3.0V application.

A headphone or mute detection is included in the AS1748 and AS1750. This function is realized with a comparator which has an internally generated thresh-hold of about 1/3 of V_{CC} . To reduce click-and-pop sounds when switching between precharged points the AS1749 and AS1750 have an internal shunt switch. This shunt switch automatically discharges any capacitance at the NO and NC connection points.

9 Application Information

Digital Control Inputs

The logic inputs of the AS1747– AS1750 accept up to +5.5V independent of the supply voltage. Due to this a mixing of the logic levels in a system is possible. For example, with a +3.3V supply, IN_{-} can be driven low to GND and high to +5.5V. For a +1.8V supply voltage, the logic levels are 0.5V (low) and 1.4V (high); for a +5V supply voltage, the logic levels are 0.8V (low) and 2.0V (high).

Analog Signal Levels

The change of the on-resistance of the AS1747– AS1750 is very little for analog input signals over the whole supply voltage range. The switches are bi-directional, so the NO_{-} , NC_{-} , and COM_{-} pins can be either inputs or outputs.

The AS1747– AS1750 pass signals as low as $V_{CC} - 5.5V$, including signals below ground with minimal distortion.

Comparator (AS1748¹/AS1750)

To implement a mute and headphone function, a comparator is included in the AS1748 and AS1750. The negative terminal of this comparator is connected to the outside (via pin CMP_{-}) while the positive terminal is internally set to $V_{CC}/3$. The output of the comparator ($CMPO$) is logic high when the negative terminal (CMP_{-}) is below the threshold. $CMPO$ is logic low when CMP_{-} is higher than $V_{CC}/3$.

Headphone audio signals are typical biased to $V_{CC}/2$ so a comparator threshold of $V_{CC}/3$ is sufficient for the headphone detection.

Shunt Switch (AS1749¹/AS1750)

Due to the switching between audio sources, audible click-and-pop sounds occur. To reduce this sounds a 100Ω shunt switch is implemented in the AS1749 and AS1750. This shunt switch automatically discharges any capacitance at the NC_{-} or NO_{-} terminals when they are unconnected to COM_{-} .

Audible clicks and pops are caused when a step DC voltage is switched into the speaker. By automatically discharging the side that is not connected, any residual DC voltage is removed, thereby reducing the clicks and pops.

Power-Supply Sequencing and Overvoltage Protection

Caution: Stresses beyond the listed absolute maximum ratings in [Table 3 on page 4](#) may cause permanent damage to the device. Exposure to absolute maximum rating conditions for extended periods may affect device reliability.

Proper power-supply sequencing is recommended for all CMOS devices. Always apply V_{CC} before applying analog signals, especially if the analog signal is not current-limited.

1. on request

10 Timing Diagrams

Figure 19. Switching Time

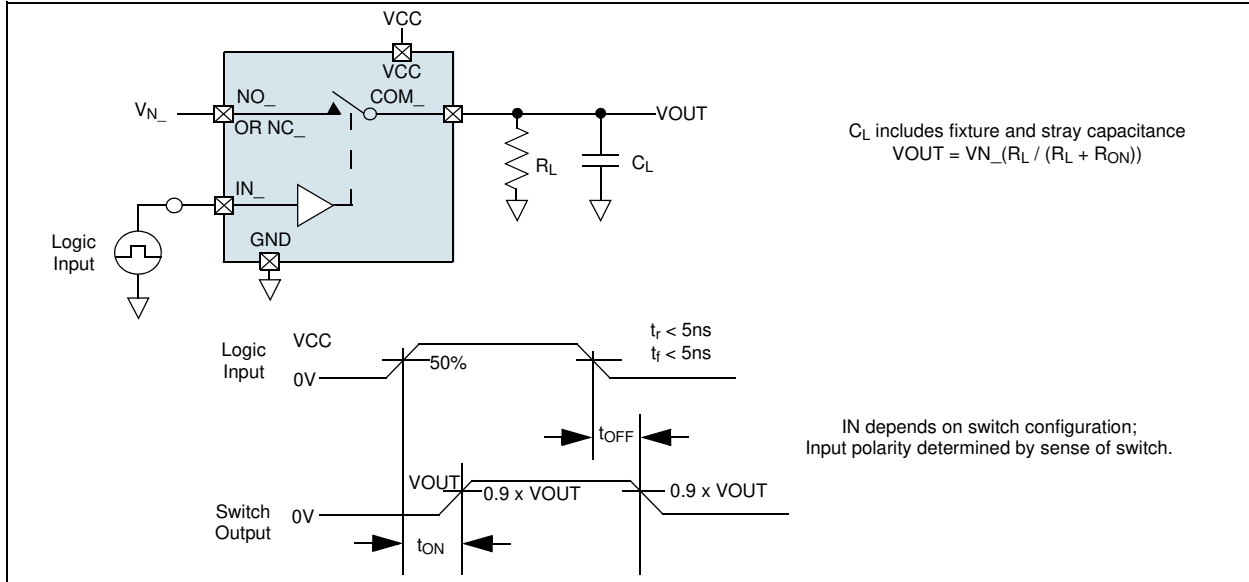

Figure 20. Break-Before-Make Interval

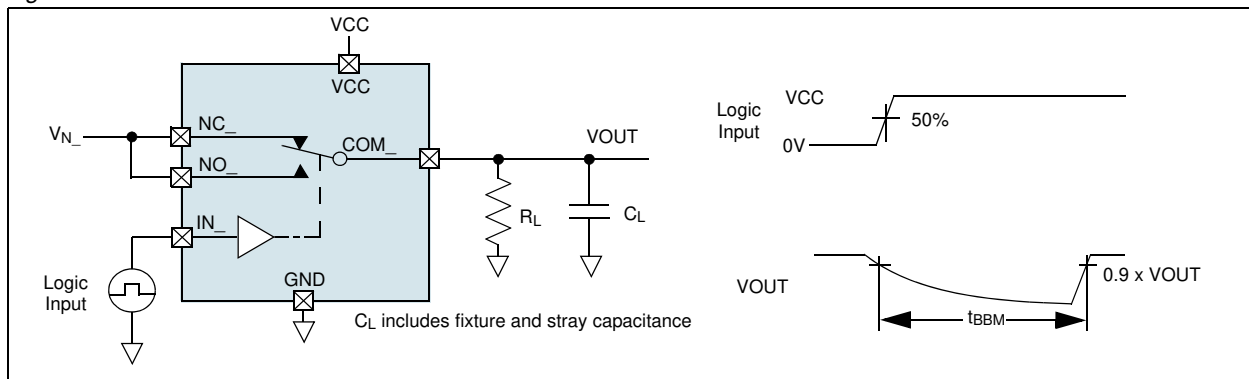

Figure 21. Charge Injection

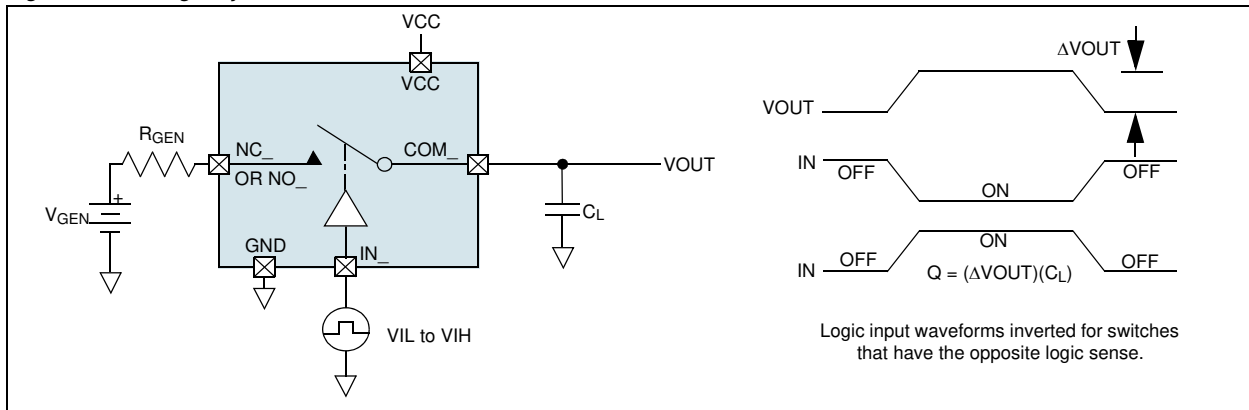
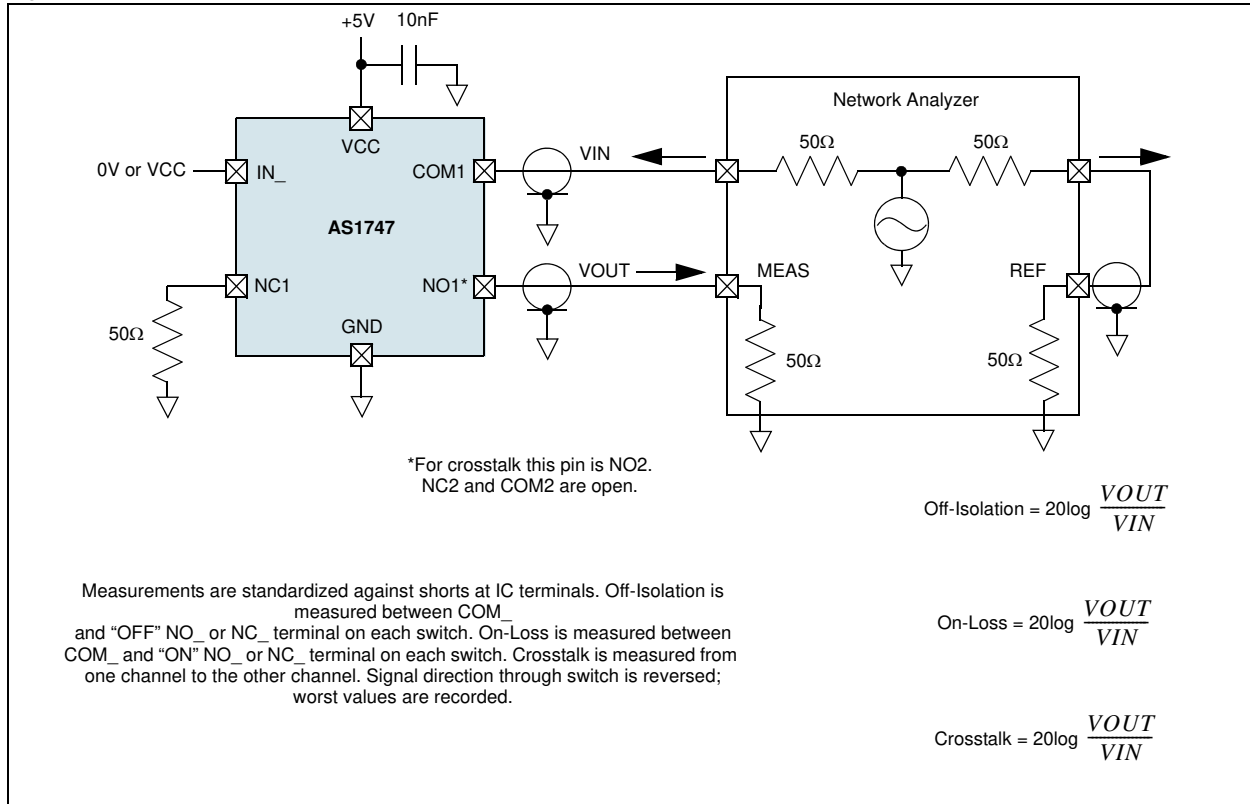

Figure 22. On-Loss, Off-Isolation, and Crosstalk



11 Package Drawings and Markings

The devices are available in 10-pin TDFN 3x3, 16-pin TQFN 3x3 package.

Figure 23. 10-pin TDFN 3x3 Package Dimensions

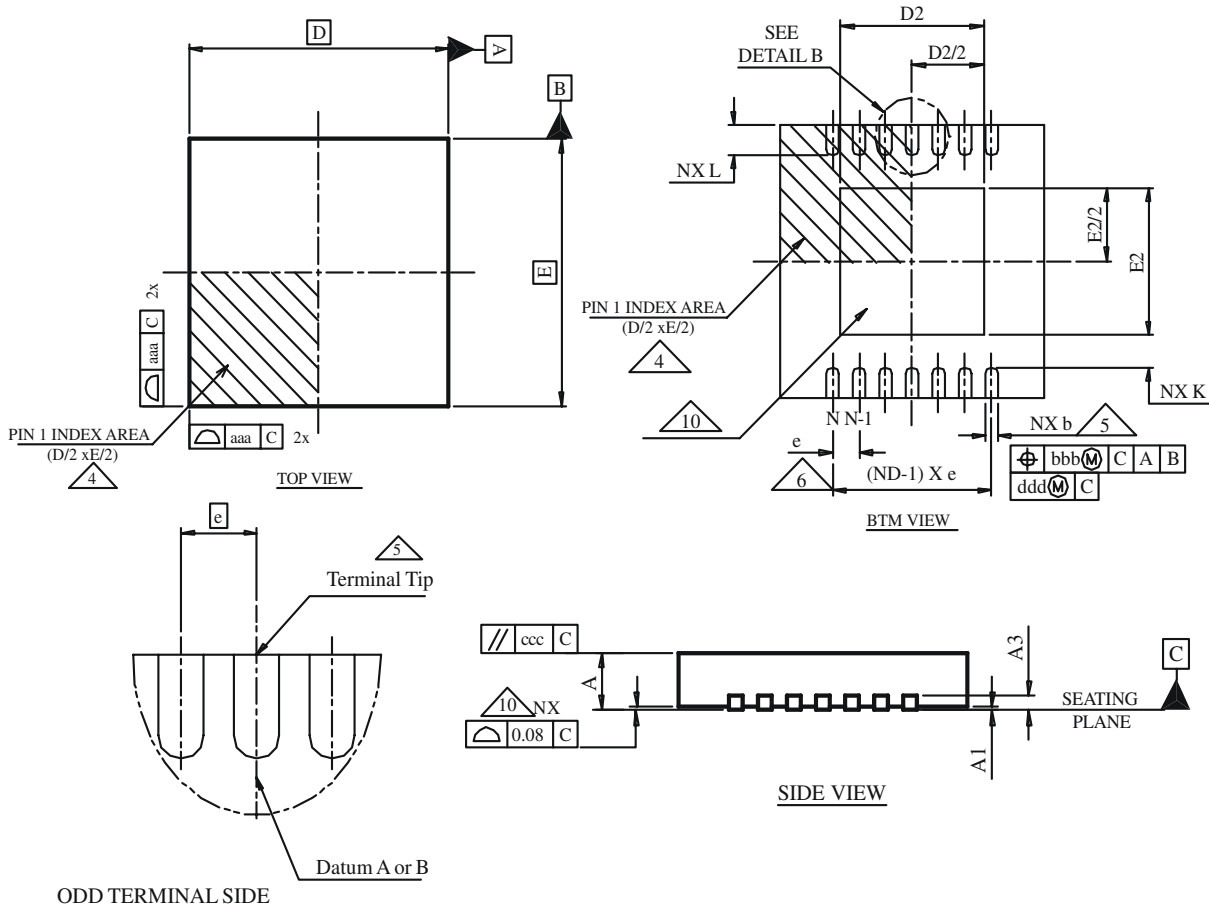

Symbol	Min	Nom	Max	Notes
A	0.70	0.75	0.80	
A1	0.00	0.02	0.05	
A3	0.20 REF			
θ	0°	---	14°	
aaa	0.15			
bbb	0.10			
ccc	0.10			
ddd	0.05			
eee	0.08			
ggg	0.10			

Symbol	Min	Nom	Max	Notes
D BSC	3.00			
E BSC	3.00			
D2	2.20	---	2.70	
E2	1.40	---	1.75	
L	0.30	0.40	0.50	
K	0.20	---	---	
b	0.18	0.25	0.30	
e	0.50			
N	10	N	10	
ND	5	ND	5	

Notes:

1. All dimensions are in millimeters, angle is in degrees.
2. N is the total number of terminals.
3. ND refers to the maximum number of terminals on D side.

Figure 24. 16-pin TQFN 3x3 Package Dimensions

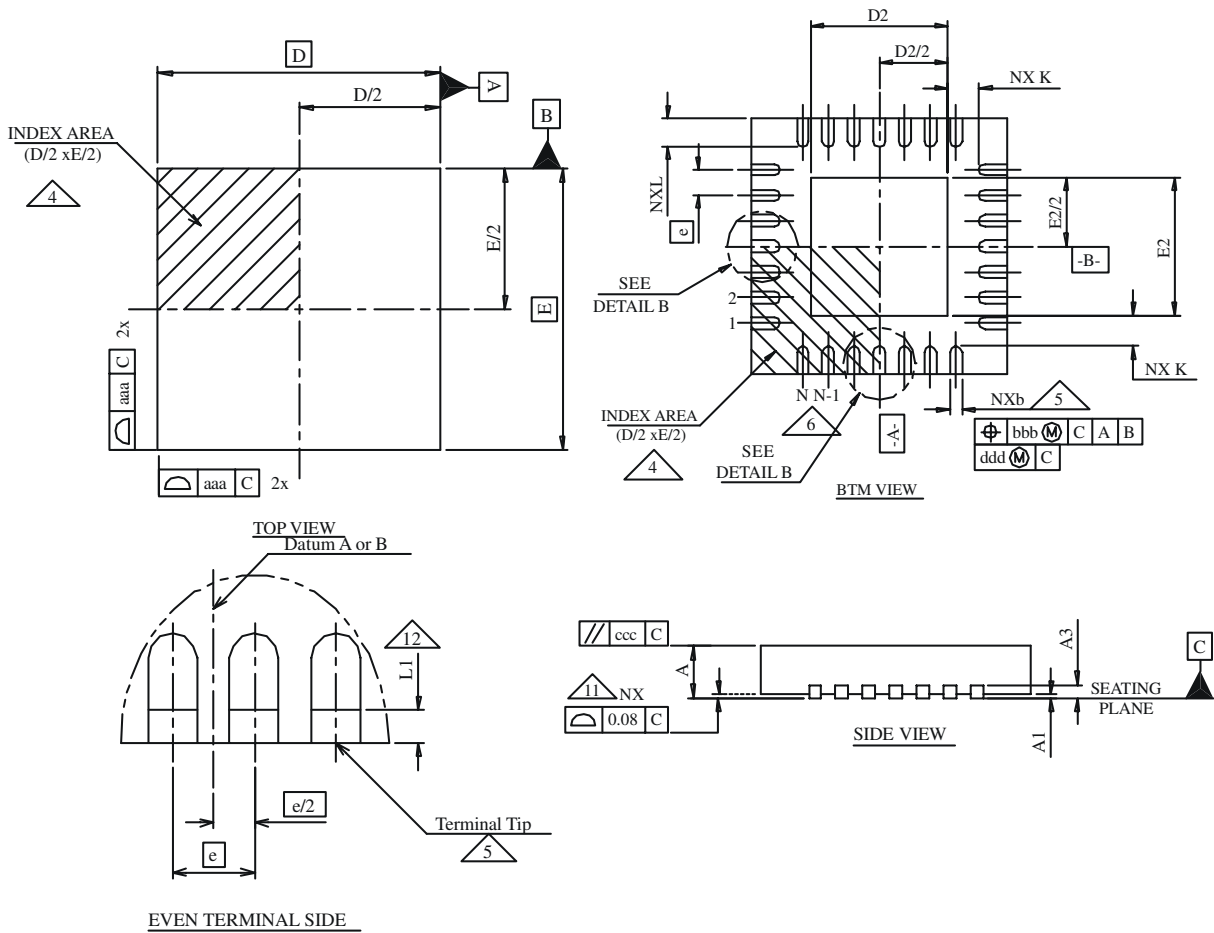

Symbol	Min	Nom	Max	Notes
A	0.70	0.75	0.80	
A1	0.00	0.02	0.05	
A3	0.20 REF			
L1	0.03	---	0.15	
b	0.18	0.25	0.30	
e	0.50			
aaa	0.15			
bbb	0.10			
ccc	0.10			
ddd	0.05			

Symbol	Min	Nom	Max	Notes
K	0.20	1.45	---	
D BSC	3.00			
E BSC	3.00			
D2	1.30	1.45	1.55	
E2	1.30	0.40	1.55	
L	0.30	0.40	0.50	
N	16			
ND	4			
NE	4			

12 Ordering Information

The devices are available as the standard products shown in [Table 5](#).

Table 5. Ordering Information

Ordering Code	Marking	Description	Delivery Form	Package
AS1747-BTDT	ASPV	Dual 0.6Ohm SPDT, Audio Clickless Switch with Negative Rail Capability	Tape and Reel	10-pin TDFN 3x3
AS1747-BTDR*	ASPV	Dual 0.6Ohm SPDT, Audio Clickless Switch with Negative Rail Capability	Tray	10-pin TDFN 3x3
AS1747-BWLT*	ASPV	Dual 0.6Ohm SPDT, Audio Clickless Switch with Negative Rail Capability	Tape and Reel	10-Bump WL-CSP
AS1748-BQFT*	ASPW	Dual 0.6Ohm SPDT, Audio Clickless Switch with Negative Rail Capability, with Comparator	Tape and Reel	16-pin TQFN 3x3
AS1748-BQFR*	ASPW	Dual 0.6Ohm SPDT, Audio Clickless Switch with Negative Rail Capability, with Comparator	Tray	16-pin TQFN 3x3
AS1748-BWLT*	ASPW	Dual 0.6Ohm SPDT, Audio Clickless Switch with Negative Rail Capability, with Comparator	Tape and Reel	12-Bump WL-CSP
AS1749-BTDT*	ASPX	Dual 0.6Ohm SPDT, Audio Clickless Switch with Negative Rail Capability, with Internal Shunt	Tape and Reel	10-pin TDFN 3x3
AS1749-BTDR*	ASPX	Dual 0.6Ohm SPDT, Audio Clickless Switch with Negative Rail Capability, with Internal Shunt	Tray	10-pin TDFN 3x3
AS1749-BWLT*	ASPX	Dual 0.6Ohm SPDT, Audio Clickless Switch with Negative Rail Capability, with Internal Shunt	Tape and Reel	10-Bump WL-CSP
AS1750-BQFT	ASPY	Dual 0.6Ohm SPDT, Audio Clickless Switch with Negative Rail Capability, with Comparator & Internal Shunt	Tape and Reel	16-pin TQFN 3x3
AS1750-BQFR*	ASPY	Dual 0.6Ohm SPDT, Audio Clickless Switch with Negative Rail Capability, with Comparator & Internal Shunt	Tray	16-pin TQFN 3x3
AS1750-BWLT*	ASPY	Dual 0.6Ohm SPDT, Audio Clickless Switch with Negative Rail Capability, with Comparator & Internal Shunt	Tape and Reel	12-Bump WL-CSP

* on request

Note: All products are RoHS compliant and Pb-free.

Buy our products or get free samples online at ICdirect: <http://www.austriamicrosystems.com/ICdirect>

For further information and requests, please contact us <mailto:sales@austriamicrosystems.com>
or find your local distributor at <http://www.austriamicrosystems.com/distributor>

Copyrights

Copyright © 1997-2010, austriamicrosystems AG, Tobelbaderstrasse 30, 8141 Unterpremstaetten, Austria-Europe. Trademarks Registered ®. All rights reserved. The material herein may not be reproduced, adapted, merged, translated, stored, or used without the prior written consent of the copyright owner.

All products and companies mentioned are trademarks or registered trademarks of their respective companies.

Disclaimer

Devices sold by austriamicrosystems AG are covered by the warranty and patent indemnification provisions appearing in its Term of Sale. austriamicrosystems AG makes no warranty, express, statutory, implied, or by description regarding the information set forth herein or regarding the freedom of the described devices from patent infringement. austriamicrosystems AG reserves the right to change specifications and prices at any time and without notice. Therefore, prior to designing this product into a system, it is necessary to check with austriamicrosystems AG for current information. This product is intended for use in normal commercial applications. Applications requiring extended temperature range, unusual environmental requirements, or high reliability applications, such as military, medical life-support or life-sustaining equipment are specifically not recommended without additional processing by austriamicrosystems AG for each application. For shipments of less than 100 parts the manufacturing flow might show deviations from the standard production flow, such as test flow or test location.

The information furnished here by austriamicrosystems AG is believed to be correct and accurate. However, austriamicrosystems AG shall not be liable to recipient or any third party for any damages, including but not limited to personal injury, property damage, loss of profits, loss of use, interruption of business or indirect, special, incidental or consequential damages, of any kind, in connection with or arising out of the furnishing, performance or use of the technical data herein. No obligation or liability to recipient or any third party shall arise or flow out of austriamicrosystems AG rendering of technical or other services.



Contact Information

Headquarters

austriamicrosystems AG
Tobelbaderstrasse 30
A-8141 Unterpremstaetten, Austria

Tel: +43 (0) 3136 500 0
Fax: +43 (0) 3136 525 01

For Sales Offices, Distributors and Representatives, please visit:

<http://www.austriamicrosystems.com/contact>