

PRODUCT NO.

SEE SHEET 4

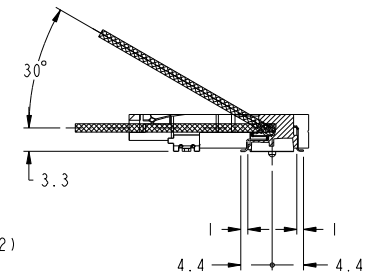

SECTION XI-XI

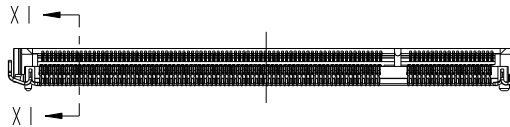
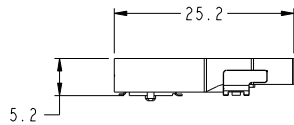
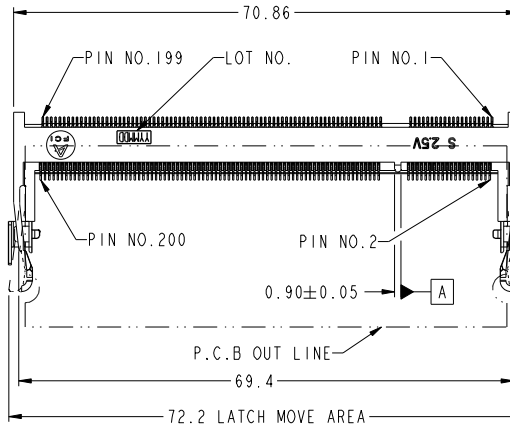
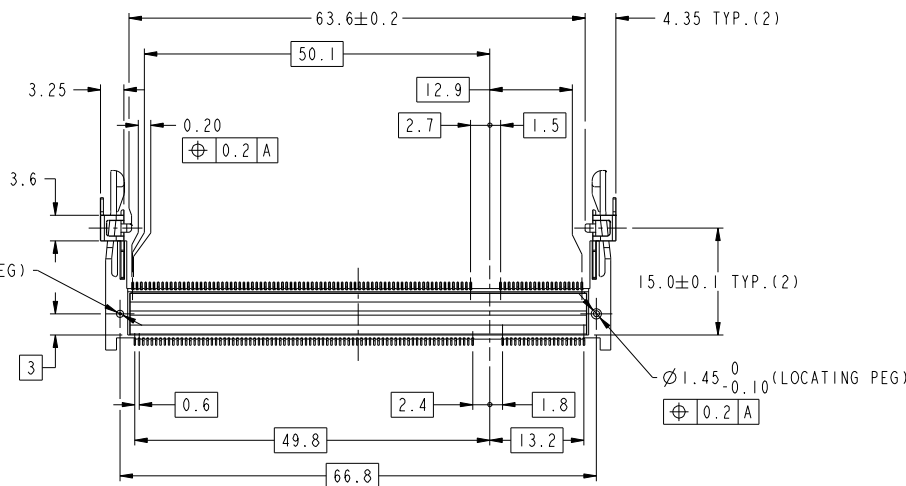

NOTE

1. PRODUCT SPEC. : GS-12-195
2. PACKAGING SPEC. : GS-14-786
3. MATERIAL:
1) HOUSING : LCP, UL94V-0, COLOR BLACK
2) CONTACT : COPPER ALLOY
3) HOLD DOWN : BRASS
4. FINISH
1) TERMINAL : SEE TABLE
2) HOLD DOWN : SEE TABLE
5. CO-PLANARITY : 0.1 MAX. (INCLUDE HOLD DOWN)
6. THIS PRODUCT MEETS EUROPEAN UNION DIRECTIVES AND OTHER COUNTRY REGULATIONS AS DESCRIBED IN GS-22-008.
7. THE HOUSING WILL WITHSTAND EXPOSURE TO 260° PEAK TEMPERATURE FOR 10 SECONDS IN A REFLOW SOLDER APPLICATION.

Copyright FCI

rev	ecn no	dr	date
A	DG11-0085	SH	2011-03-29
-	-	-	-
-	-	-	-
-	-	-	-
-	-	-	-

www.fciconnect.com		surface ASME Y14.5	tolerance std ASME Y14.5	projection	MM
TOLERANCES UNLESS OTHERWISE SPECIFIED		ANGULAR	LINEAR	size	Scale
		0° ±2°	0.0xx ±0.15	A2	1:1
		0° ±2°	0.0xx ±0.08	ECN	DG11-0085
Appr HSI A JOSEPH		2011-03-29	Product family	50UF	SO-DIMM
FCI		DDR SO-DIMM 0.6mm PITCH 200 POS	STANDARD TYPE ASS'Y	10117867C	Rev. A
catalog no		CUSTOMER COPY		sheet 1 of 4	

PRODUCT NO.
10117867-x52xx

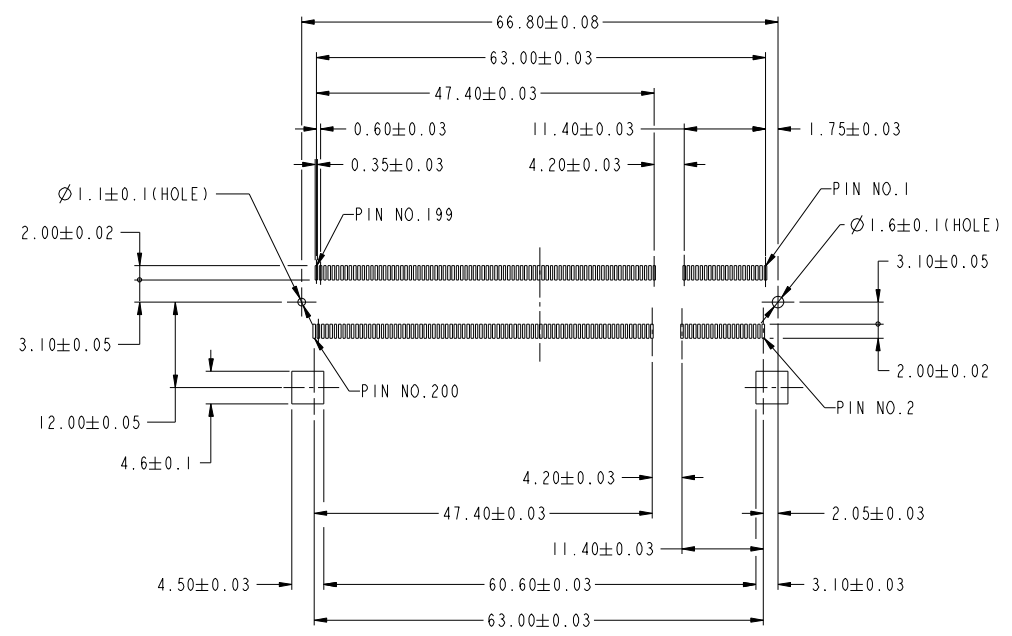

RECOMMENDED MOUNTING P.C.B. LAYOUT

Copyright FCI.
FCI

FCI	DDR SO-DIMM 0.6mm PITCH 200 POS	diag no	10117867C	Rev.	A
	STANDARD TYPE ASS'Y	catalog no	CUSTOMER COPY	sheet 2 of 4	

1		2		3		4		5		6		7		8				
PRODUCT NO.	LOCATING PEG	TERMINAL CONTACT AREA FINISH	HOLD DOWN FINISH	SOLDER TAIL FINISH														
10117867-052FS	YES	Au FLASH	Pure Sn PLATING	Au FLASH PLATING	10117867-	□	□	□	□	LF	For Rohs OPTIONS: TAIL PLATING CODE MUST BE 0-3. HOLD DOWN PLATING CODE MUST BE "S". "LF" CODE IS EXIST IN THE END. EX: 10117867-252TSLF	FOR NOT Rohs COMPATIBLE: THIS "LF" CODE IS "BLANK". EX:10117867-452TS	<PACKING METHOD> R : TAPE REEL DEFAULT : TRAY	<HOLD DOWN FINISH> S : Pure Sn B : Sn-Pb	<CONTACT AREA FINISH> F : Au FLASH T : Au 0.3µm MIN. A : Au 0.76µm MIN.	<TOTAL HEIGHT> 52 : 5.2mm	<LOCATING PEG, SOLDER TAIL FINISH> 0 : YES, Au FLASH 1 : NO, Au FLASH 2 : YES, Pure Sn PLATING 3 : NO, Pure Sn PLATING 4 : YES, Sn-Pb PLATING 5 : NO, Sn-Pb PLATING	
10117867-152FS	NO																	
10117867-052TS	YES	Au 0.3µm MIN.																
10117867-152TS	NO																	
10117867-052AS	YES	Au 0.76µm MIN.																
10117867-152AS	NO																	
10117867-052FC	YES	Au FLASH																Sn-Cu PLATING
10117867-152FC	NO																	
10117867-052TC	YES	Au 0.3µm MIN.																
10117867-152TC	NO																	
10117867-052AC	YES	Au 0.76µm MIN.																
10117867-152AC	NO																	
10117867-252FS	YES	Au FLASH	Pure Sn PLATING															
10117867-352FS	NO																	
10117867-252TS	YES	Au 0.3µm MIN.																
10117867-352TS	NO																	
10117867-252AS	YES	Au 0.76µm MIN.																
10117867-352AS	NO																	
10117867-252FC	YES	Au FLASH		Sn-Cu PLATING														
10117867-352FC	NO																	
10117867-252TC	YES	Au 0.3µm MIN.																
10117867-352TC	NO																	
10117867-252AC	YES	Au 0.76µm MIN.																
10117867-352AC	NO																	
10117867-452FS	YES	Au FLASH	Pure Sn PLATING															
10117867-552FS	NO																	
10117867-452TS	YES	Au 0.3µm MIN.																
10117867-552TS	NO																	
10117867-452AS	YES	Au 0.76µm MIN.																
10117867-552AS	NO																	
10117867-452FC	YES	Au FLASH		Sn-Pb PLATING														
10117867-552FC	NO																	
10117867-452TC	YES	Au 0.3µm MIN.																
10117867-552TC	NO																	
10117867-452AC	YES	Au 0.76µm MIN.																
10117867-552AC	NO																	

Copyright FCI.

FCI	TITLE	DDR SO-DIMM 0.6mm PITCH 200 POS	Rev.	A
	STANDARD TYPE ASS'Y		10117867C	
CATALOG NO.	CUSTOMER COPY		sheet 4 of 4	