

SIX-OUTPUT PCIe GEN 3 BUFFER/ZERO DELAY BUFFER

Features

- Six 0.7 V low-power, push-pull, HCSL-compatible PCIe Gen 3 outputs
- Individual OE HW pins for each output clock
- 100 MHz /133 MHz PLL operation, supports PCIe and QPI
- PLL bandwidth SW SMBUS programming overrides the latch value from HW pin
- SMBus address configurable to allow multiple buffers in a single control network 3.3 V supply voltage operation
- Low phase jitter (Intel QPI, PCIe Gen 1/2/3/4 common clock compliant)
- Gen 3 SRNS Compliant
- PLL or bypass mode
- Spread spectrum tolerable
- 1.05 to 3.3 V I/O supply voltage
- 50 ps output-to-output skew
- Industrial Temperature: -40 to 85 °C
- 40-pin QFN
- For higher output devices or variations of this device, contact Skyworks Solutions



Patents pending

Applications

- Server
- Storage
- Datacenter
- Enterprise Switches and Routers

Description

The Si53106 is a low-power, 6-output, differential clock buffer that meets all of the performance requirements of the Intel DB1200ZL specification. The device is optimized for distributing reference clocks for Intel® Quick-Path Interconnect (Intel QPI), PCIe Gen 1/Gen 2/Gen 3/Gen 4, SAS, SATA, and Intel Scalable Memory Interconnect (Intel SMI) applications. The VCO of the device is optimized to support 100 MHz and 133 MHz operation. Each differential output has a dedicated hardware output enable pin for maximum flexibility and power savings. Measuring PCIe clock jitter is quick and easy with the Skyworks Solutions PCIe Clock Jitter Tool. Download it for free at <https://www.skyworksinc.com/en/application-pages/pci-express-learning-center>.

Si53106

Functional Block Diagram

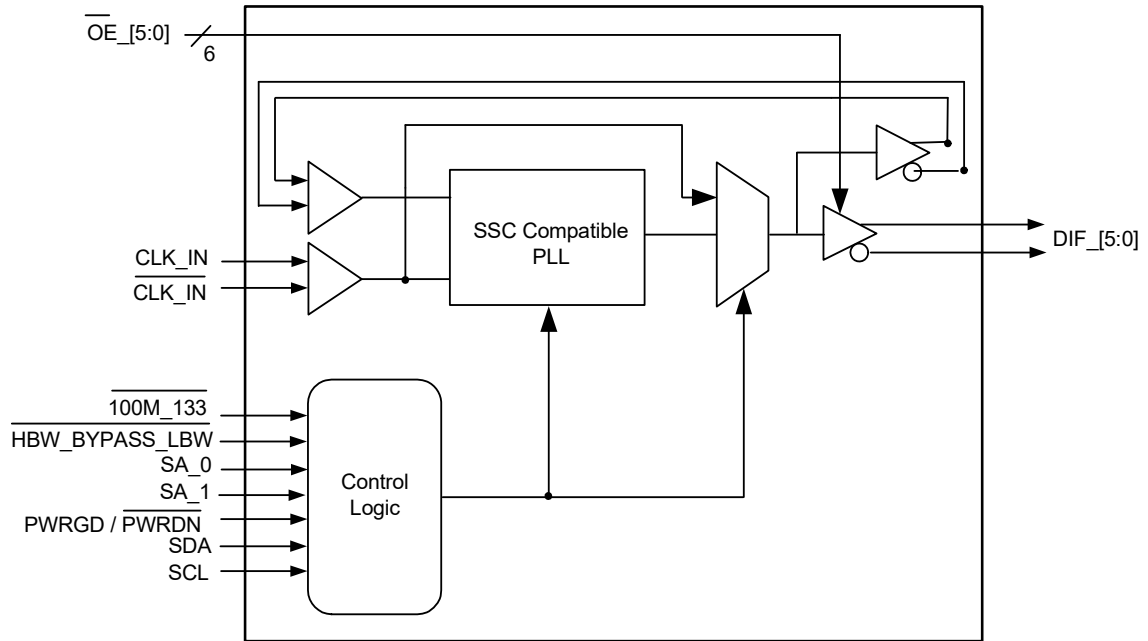

TABLE OF CONTENTS

Section	Page
1. Electrical Specifications	4
2. Functional Description	12
2.1. CLK_IN, CLK_IN	12
2.2. OE and Output Enables (Control Registers)	12
2.3. 100M_133M—Frequency Selection	12
2.4. SA_0, SA_1—Address Selection	13
2.5. PWRGD/PWRDN	13
2.6. HBW_BYPASS_LBW	15
2.7. Miscellaneous Requirements	15
3. Test and Measurement Setup	16
3.1. Input Edge	16
3.2. Termination of Differential Outputs	17
4. Control Registers	18
4.1. Byte Read/Write	18
4.2. Block Read/Write	19
4.3. Control Registers	20
5. Power Filtering Example	25
5.1. Ferrite Bead Power Filtering	25
6. Pin Descriptions: 40-Pin QFN	26
7. Ordering Guide	29
8. Package Outline	30
9. Land Pattern	31
Document Change List	33

1. Electrical Specifications

Table 1. DC Operating Characteristics

$V_{DD_A} = 3.3\text{ V} \pm 5\%$, $V_{DD} = 3.3\text{ V} \pm 5\%$

Parameter	Symbol	Test Condition	Min	Max	Unit
3.3 V Core Supply Voltage	VDD/VDD_A	3.3 V $\pm 5\%$	3.135	3.465	V
3.3 V I/O Supply Voltage ¹	VDD_IO	1.05 V to 3.3 V $\pm 5\%$	0.9975	3.465	V
3.3 V Input High Voltage	V _{IH}	VDD	2.0	VDD+0.3	V
3.3 V Input Low Voltage	V _{IL}		VSS-0.3	0.8	V
Input Leakage Current ²	I _{IL}	0 < V _{IN} < VDD	-5	+5	μA
3.3 V Input High Voltage ³	V _{IH_FS}	VDD	0.7	VDD+0.3	V
3.3 V Input Low Voltage ³	V _{IL_FS}		VSS-0.3	0.35	V
3.3 V Input Low Voltage	V _{IL_Tri}		0	0.8	V
3.3 V Input Med Voltage	V _{IM_Tri}		1.2	1.8	V
3.3 V Input High Voltage	V _{IH_Tri}		2.4	VDD	V
3.3 V Output High Voltage ⁴	V _{OH}	I _{OH} = -1 mA	2.4	—	V
3.3 V Output Low Voltage ⁴	V _{OL}	I _{OL} = 1 mA	—	0.4	V
Input Capacitance ⁵	C _{IN}		2.5	4.5	pF
Output Capacitance ⁵	C _{OUT}		2.5	4.5	pF
Pin Inductance	L _{PIN}		—	7	nH
Ambient Temperature	T _A	No Airflow	-40	85	$^{\circ}\text{C}$

Notes:

- VDD_IO applies to the low-power NMOS push-pull HCSL compatible outputs.
- Input Leakage Current does not include inputs with pull-up or pull-down resistors. Inputs with resistors should state current requirements.
- Internal voltage reference is to be used to guarantee V_{IH_FS} and V_{IL_FS} thresholds levels over full operating range.
- Signal edge is required to be monotonic when transitioning through this region.
- C_{comp} capacitance based on pad metallization and silicon device capacitance. Not including pin capacitance.

Table 2. Current Consumption

T_A = -40 to 85 $^{\circ}\text{C}$; supply voltage V_{DD} = 3.3 V $\pm 5\%$

Parameter	Symbol	Test Condition	Min	Typ	Max	Unit
Operating Current	ID _{DVDD}	133 MHz, VDD Rail	—	19	30	mA
	ID _{DVDDA}	133 MHz, VDDA + VDDR, PLL Mode	—	15	25	mA
	ID _{DVDDIO}	133 MHz, CL = Full Load, VDD IO Rail	—	49	65	mA
Power Down Current	ID _{DVDDPD}	Power Down, VDD Rail	—	0.45	1	mA
	ID _{DVDDAPD}	Power Down, VDDA Rail	—	4.5	7	mA
	ID _{DVDDIOPD}	Power Down, VDD_IO Rail	—	0.23	0.5	mA

Table 3. Output Skew, PLL Bandwidth and PeakingT_A = -40 to 85 °C; supply voltage V_{DD} = 3.3 V ±5%

Parameter	Test Condition	Min	Typ	Max	Unit
CLK_IN, DIF[x:0]	Input-to-Output Delay in PLL Mode Nominal Value ^{1,2,3,4}	-100	-15	100	ps
CLK_IN, DIF[x:0]	Input-to-Output Delay in Bypass Mode Nominal Value ^{2,4,5}	2.5	3.6	4.5	ns
CLK_IN, DIF[x:0]	Input-to-Output Delay Variation in PLL mode Over voltage and temperature ^{2,4,5}	-100	39	100	ps
CLK_IN, DIF[x:0]	Input-to-Output Delay Variation in Bypass Mode Over voltage and temperature ^{2,4,5}	-250	3.7	250	ps
DIF[11:0]	Output-to-Output Skew across all 6 Outputs (Common to Bypass and PLL Mode) ^{1,2,3,4,5}	0	20	50	ps
PLL Jitter Peaking	(HBW_BYPASS_LBW = 0) ⁶	—	0.4	2.0	dB
PLL Jitter Peaking	(HBW_BYPASS_LBW = 1) ⁶	—	0.1	2.5	dB
PLL Bandwidth	(HBW_BYPASS_LBW = 0) ⁷	—	0.7	1.4	MHz
PLL Bandwidth	(HBW_BYPASS_LBW = 1) ⁷	—	2	4	MHz

Notes:

1. Measured into fixed 2 pF load cap. Input-to-output skew is measured at the first output edge following the corresponding input.
2. Measured from differential cross-point to differential cross-point.
3. This parameter is deterministic for a given device.
4. Measured with scope averaging on to find mean value.
5. All Bypass Mode Input-to-Output specs refer to the timing between an input edge and the specific output edge created by it.
6. Measured as maximum pass band gain. At frequencies within the loop BW, highest point of magnification is called PLL jitter peaking.
7. Measured at 3 db down or half power point.

Table 4. Clock Input Parameters

$T_A = -40$ to 85 °C; supply voltage $V_{DD} = 3.3$ V $\pm 5\%$

Parameter	Symbol	Test Condition	Min	Typ	Max	Unit
Input Frequency	F_{IN}	Bypass Mode	33	—	150	MHz
		PLL Mode, 100 MHz	90	100	110	MHz
		PLL Mode, 133.33 MHz	120	133.33	147	MHz
Input High Voltage- CLK_IN	V_{IHDIF}	Differential inputs single-ended measurement	600	800	1150	mV
Input Low Voltage- CLK_IN	V_{ILDIF}	Differential inputs single-ended measurement	$V_{SS} - 300$	0	300	mV
Input Common Mode Voltage - CLK_IN	V_{COM}	Common Mode Voltage Input	300	—	1000	mV
Input Amplitude- CLK_IN	V_{Swing}	Peak to Peak	300	—	1450	
Input Slew Rate- CLK_IN	IDD_{VDDAPD}	Measured differentially	0.4	—	8	V/ns
Input Leakage Current	I_{IN}	$V_{IN} = V_{DD}$, $V_{IN} = GND$	-5	—	5	μA
Input Duty Cycle	d_{tin}	Measured from differential waveform	45	—	55	%
Input Jitter, Cycle-Cycle	J_{DIFIN}	Differential measurement	0	—	125	ps
Input SS Modulation Frequency	f_{MODIN}	Triangle Wave Modulation	30	—	33	kHz

Table 5. Phase Jitter

Parameter	Test Condition	Min	Typ	Max	Unit
Phase Jitter PLL Mode	PCIe Gen 1, Common Clock ^{1,2,3}	—	29	86	ps
	PCIe Gen 2 Low Band, Common Clock F < 1.5 MHz ^{1,3,4,5}	—	2.3	3.0	ps (RMS)
	PCIe Gen 2 High Band, Common Clock 1.5 MHz < F < Nyquist ^{1,3,4,5}	—	2.4	3.1	ps (RMS)
	PCIe Gen 3, Common Clock (PLL BW 2–4 MHz, CDR = 10 MHz) ^{1,3,4,5}	—	0.6	1.0	ps (RMS)
	PCIe Gen 3 Separate Reference No Spread, SRNS (PLL BW of 2–4 or 2–5 MHz, CDR = 10 MHz) ^{1,3,4,5}	—	0.42	0.71	ps (RMS)
	PCIe Gen 4, Common Clock (PLL BW of 2–4 or 2–5 MHz, CDR = 10 MHz) ^{1,4,5,8}	—	0.6	1.0	ps (RMS)
	Intel [®] QPI & Intel SMI (4.8 Gbps or 6.4 Gb/s, 100 or 133 MHz, 12 UI) ^{1,6,7}	—	0.21	0.5	ps (RMS)
	Intel QPI & Intel SMI (8 Gb/s, 100 MHz, 12 UI) ^{1,6}	—	0.13	0.3	ps (RMS)
	Intel QPI & Intel SMI (9.6 Gb/s, 100 MHz, 12 UI) ^{1,6}	—	0.11	0.2	ps (RMS)

Notes:

1. Post processed evaluation through Intel supplied Matlab* scripts. Defined for a BER of 1E-12. Measured values at a smaller sample size have to be extrapolated to this BER target.
2. $\zeta = 0.54$ implies a jitter peaking of 3 dB.
3. PCIe* Gen 3 filter characteristics are subject to final ratification by PCISIG. Check the PCI-SIG for the latest specification.
4. Measured on 100 MHz PCIe output using the template file in the Intel-supplied Clock Jitter Tool V1.6.3.
5. Measured on 100 MHz output using the template file in the Intel-supplied Clock Jitter Tool V1.6.3.
6. Measured on 100 MHz, 133 MHz output using the template file in the Intel-supplied Clock Jitter Tool V1.6.3.
7. These jitter numbers are defined for a BER of 1E-12. Measured numbers at a smaller sample size have to be extrapolated to this BER target.
8. Gen 4 specifications based on the PCI-Express Base Specification 4.0 rev. 0.5.
9. Download the Skyworks Solutions PCIe Clock Jitter Tool at <https://www.skyworksinc.com/en/application-pages/pci-express-learning-center>.

Table 5. Phase Jitter (Continued)

Additive Phase Jitter Bypass Mode	PCIe Gen 1 ^{1,2,3}	—	10	—	ps
	PCIe Gen 2 Low Band F < 1.5 MHz ^{1,3,4,5}	—	1.6	—	ps (RMS)
	PCIe Gen 2 High Band 1.5 MHz < F < Nyquist ^{1,3,4,5}	—	1.6	—	ps (RMS)
	PCIe Gen 3 (PLL BW 2–4 MHz, CDR = 10 MHz) ^{1,3,4,5}	—	0.4	—	ps (RMS)
	PCIe Gen 4, Common Clock (PLL BW of 2–4 or 2–5 MHz, CDR = 10 MHz) ^{1,4,5,8}	—	0.4	—	ps (RMS)
	Intel QPI & Intel® SMI (4.8 Gbps or 6.4 Gb/s, 100 or 133 MHz, 12 UI) ^{1,6,7}	—	0.12	—	ps (RMS)
	Intel QPI & Intel® SMI (8 Gb/s, 100 MHz, 12 UI) ^{1,6}	—	0.1	—	ps (RMS)
	Intel QPI & Intel® SMI (9.6 Gb/s, 100 MHz, 12 UI) ^{1,6}	—	0.09	—	ps (RMS)

Notes:

1. Post processed evaluation through Intel supplied Matlab* scripts. Defined for a BER of 1E-12. Measured values at a smaller sample size have to be extrapolated to this BER target.
2. $\zeta = 0.54$ implies a jitter peaking of 3 dB.
3. PCIe* Gen 3 filter characteristics are subject to final ratification by PCISIG. Check the PCI-SIG for the latest specification.
4. Measured on 100 MHz PCIe output using the template file in the Intel-supplied Clock Jitter Tool V1.6.3.
5. Measured on 100 MHz output using the template file in the Intel-supplied Clock Jitter Tool V1.6.3.
6. Measured on 100 MHz, 133 MHz output using the template file in the Intel-supplied Clock Jitter Tool V1.6.3.
7. These jitter numbers are defined for a BER of 1E-12. Measured numbers at a smaller sample size have to be extrapolated to this BER target.
8. Gen 4 specifications based on the PCI-Express Base Specification 4.0 rev. 0.5.
9. Download the Skyworks Solutions PCIe Clock Jitter Tool at <https://www.skyworksinc.com/en/application-pages/pci-express-learning-center>.

Table 6. DIF 0.7 V AC Timing Characteristics (Non-Spread Spectrum Mode)¹

Parameter	Symbol	CLK 100 MHz, 133 MHz			Unit	Notes
		Min	Typ	Max		
Clock Stabilization Time	T_{STAB}	—	1.5	1.8	ms	2
Long Term Accuracy	L_{ACC}	—	—	100	ppm	3,4,5
Absolute Host CLK Period (100MHz)	T_{ABS}	9.94900	—	10.05100	ns	3,4,6
Absolute Host CLK Period (133MHz)	T_{ABS}	7.44925	—	7.55075	ns	3,4,6
Edge Rate	Edge_rate	1.0	—	4.0	V/ns	3,4,7
Rise Time Variation	ΔT_{RISE}	—	—	125	ps	3,8,9
Fall Time Variation	ΔT_{FALL}	—	—	125	ps	3,8,9
Rise/Fall Matching	$T_{RISE_MAT}/$ T_{FALL_MAT}	—	—	20	%	3,8,10,11
Voltage High (typ 0.7 V)	V_{HIGH}	660	—	850	mV	3,8,12
Voltage Low (typ 0.7 V)	V_{LOW}	-150	—	150	mV	3,8,13
Maximum Voltage	V_{MAX}	—	—	1150	mV	8
Absolute Crossing Point Voltages	V_{OXABS}	250	—	550	mV	3,8,14,15, 16
Total Variation of V_{CROSS} Over All Edges	Total Δ V_{ox}	—	—	140	mV	3,8,18
Duty Cycle	DC	45	—	55	%	3,4
Maximum Voltage (Overshoot)	V_{ovs}	—	—	$V_{High} + 0.3$	V	3,8,19
Maximum Voltage (Undershoot)	V_{uds}	—	—	$V_{Low} - 0.3$	V	3,8,20

Table 6. DIF 0.7 V AC Timing Characteristics (Non-Spread Spectrum Mode)¹ (Continued)

Parameter	Symbol	CLK 100 MHz, 133 MHz			Unit	Notes
		Min	Typ	Max		
Ringback Voltage	V _{rb}	0.2	—	N/A	V	3, 8

Notes:

1. Unless otherwise noted, all specifications in this table apply to all processor frequencies.
2. This is the time from the valid CLK_IN input clocks and the assertion of the PWRGD signal level at 1.8–2.0 V to the time that stable clocks are output from the buffer chip (PLL locked).
3. Test configuration is R_S = 33.2 Ω, R_P = 49.9, 2 pF for 100 Ω transmission line; R_S = 27 Ω, R_P = 42.2, 2 pF for 85 Ω transmission line.
4. Measurement taken from differential waveform.
5. Using frequency counter with the measurement interval equal or greater than 0.15 s, target frequencies are 99,750,00 Hz, 133,000,000 Hz.
6. The average period over any 1 μs period of time must be greater than the minimum and less than the maximum specified period.
7. Measure taken from differential waveform on a component test board. The edge (slew) rate is measured from –150 mV to +150 mV on the differential waveform. Scope is set to average because the scope sample clock is making most of the dynamic wiggles along the clock edge Only valid for Rising clock and Falling CLOCK. Signal must be monotonic through the V_{OL} to V_{OH} region for T_{RISE} and T_{FALL}.
8. Measurement taken from single-ended waveform.
9. Measured with oscilloscope, averaging off, using min max statistics. Variation is the delta between min and max.
10. Measured with oscilloscope, averaging on, The difference between the rising edge rate (average) of clock verses the falling edge rate (average) of CLOCK.
11. Rise/Fall matching is derived using the following, $2 \cdot (T_{RISE} - T_{FALL}) / (T_{RISE} + T_{FALL})$.
12. V_{HIGH} is defined as the statistical average High value as obtained by using the Oscilloscope V_{HIGH} Math function.
13. V_{LOW} is defined as the statistical average Low value as obtained by using the Oscilloscope V_{LOW} Math function.
14. Measured at crossing point where the instantaneous voltage value of the rising edge of CLK equals the falling edge of CLK.
15. This measurement refers to the total variation from the lowest crossing point to the highest, regardless of which edge is crossing.
16. The crossing point must meet the absolute and relative crossing point specifications simultaneously.
17. V_{CROSS}(rel) Min and Max are derived using the following, V_{CROSS}(rel) Min = 0.250 + 0.5 (V_{HAVG} – 0.700), V_{CROSS}(rel) Max = 0.550 – 0.5 (0.700 – V_{HAVG}), (see Figures 3-4 for further clarification).
18. V_{CROSS} is defined as the total variation of all crossing voltages of Rising CLOCK and Falling CLOCK. This is the maximum allowed variance in V_{CROSS} for any particular system.
19. Overshoot is defined as the absolute value of the maximum voltage.
20. Undershoot is defined as the absolute value of the minimum voltage.

Table 7. Clock Periods Differential Clock Outputs with SSC Disabled

SSC ON Center Freq, MHz	Measurement Window							Unit
	1 Clock	1 μ s	0.1 s	0.1 s	0.1 s	1 μ s	1 Clock	
	-C-C Jitter AbsPer Min	-SSC Short Term AVG Min	-ppm Long Term AVG Min	0 ppm Period Nominal	+ppm Long Term AVG Max	+SSC Short Term AVG Max	+C-C Jitter AbsPer Max	
100.00	9.94900		9.99900	10.00000	10.00100		10.05100	ns
133.33	7.44925		7.49925	7.50000	7.50075		7.55075	ns

Table 8. Clock Periods Differential Clock Outputs with SSC Enabled

SSC ON Center Freq, MHz	Measurement Window							Unit
	1 Clock	1 μ s	0.1 s	0.1 s	0.1 s	1 μ s	1 Clock	
	-C-C Jitter AbsPer Min	-SSC Short Term AVG Min	-ppm Long Term AVG Min	0 ppm Period Nominal	+ppm Long Term AVG Max	+SSC Short Term AVG Max	+C-C Jitter AbsPer Max	
99.75	9.94900	9.99900	10.02406	10.02506	10.02607	10.05126	10.10126	ns
133.33	7.44925	7.49925	7.51805	7.51880	7.51955	7.53845	7.58845	ns

Table 9. Absolute Maximum Ratings

Parameter	Symbol	Min	Max	Unit
3.3 V Core Supply Voltage ¹	V_{DD}/V_{DD_A}	—	4.6	V
3.3 V I/O Supply Voltage ¹	V_{DD_IO}	—	4.6	V
3.3 V Input High Voltage ^{1,2}	V_{IH}	—	4.6	V
3.3 V Input Low Voltage ¹	V_{IL}	-0.5	—	V
Storage Temperature ¹	t_s	-65	150	°C
Input ESD protection ³	ESD	2000	—	V

Notes:

1. Consult manufacturer regarding extended operation in excess of normal dc operating parameters.
2. Maximum V_{IH} is not to exceed maximum V_{DD} .
3. Human body model.

2. Functional Description

2.1. CLK_IN, $\overline{\text{CLK_IN}}$

The differential input clock can be sourced from a clock synthesizer, e.g. CK420BQ, CK509B, or CK410B+.

2.2. $\overline{\text{OE}}$ and Output Enables (Control Registers)

Each output can be individually enabled or disabled by SMBus control register bits. Additionally, each output of the DIF[11:0] has a dedicated $\overline{\text{OE}}$ pin. The $\overline{\text{OE}}$ pins are asynchronous, asserted-low signals. The Output Enable bits in the SMBus registers are active high and are set to enable by default. The disabled state for the Si53106 NMOS push-pull output is Low/Low. Please note that the logic level for assertion or deassertion is different in software than it is on hardware. This follows hardware default nomenclature for communication channels (e.g., output is enabled if the OE# pin is pulled low) and still maintains software programming logic (e.g., output is enabled if OE register is true). Table 10 is a truth table depicting enabling and disabling of outputs via hardware and software. Note that, for the output to be active, the control register bit must be a 1 *and* the $\overline{\text{OE}}$ pin must be a 0.

Note: The assertion and deassertion of this signal is absolutely asynchronous.

Table 10. Si53106 Output Management

Inputs		$\overline{\text{OE}}$ Hardware Pins and Control Register Bits			Outputs	PLL State
PWRGD/ $\overline{\text{PWR_DN}}$	CLK_IN/ $\overline{\text{CLK_IN}}$	SMBUS Enable Bit	$\overline{\text{OE}}$ Pin	DIF/ $\overline{\text{DIF}}$ [11:0]	FB_OUT/ $\overline{\text{FB_OUT}}$	
0	x	x	x	Low/Low	Low/Low	OFF
1	Running	0	x	Low/Low	Running	ON
		1	0	Running	Running	ON
		1	1	Low/Low	Running	ON

2.2.1. $\overline{\text{OE}}$ Assertion (Transition from 1 to 0)

All differential outputs that were disabled are to resume normal operation in a glitch-free manner. The latency from the assertion to active outputs is 4 to 12 DIF clock periods.

2.2.2. $\overline{\text{OE}}$ De-Assertion (Transition from 0 to 1)

The impact of deasserting $\overline{\text{OE}}$ is that each corresponding output will transition from normal operation to disabled in a glitch-free manner. A minimum of four valid clocks will be provided after the deassertion of $\overline{\text{OE}}$. The maximum latency from the deassertion to disabled outputs is 12 DIF clock periods.

2.3. 100M_133M—Frequency Selection

The Si53106 is optimized for lowest phase jitter performance at operating frequencies of 100 and 133 MHz. 100M_133M is a hardware input pin, which programs the appropriate output frequency of the differential outputs. Note that the CLK_IN frequency must be equal to the CLK_OUT frequency; meaning Si53106 is operated in 1:1 mode only. Frequency selection can be enabled by the 100M_133M hardware pin. An external pull-up or pull-down resistor is attached to this pin to select the input/output frequency. The functionality is summarized in Table 11.

Table 11. Frequency Program Table

100M_133M	Optimized Frequency (CLK_IN = CLK_OUT)
0	133.33 MHz
1	100.00 MHz

Note: All differential outputs transition from 100 to 133 MHz or from 133 to 100 MHz in a glitch free manner.

2.4. SA_0, SA_1—Address Selection

SA_0 and SA_1 are tri-level hardware pins, which program the appropriate address for the Si53106. The two tri-level input pins that can configure the device to nine different addresses.

Table 12. SMBUS Address Table

SA_1	SA_0	SMBUS Address
L	L	D8
L	M	DA
L	H	DE
M	L	C2
M	M	C4
M	H	C6
H	L	CA
H	M	CC
H	H	CE

2.5. PWRGD/PWRDN

PWRGD is asserted high and deasserted low. Deassertion of PWRGD (pulling the signal low) is equivalent to indicating a power-down condition. PWRGD (assertion) is used by the Si53106 to sample initial configurations, such as frequency select condition and SA selections. After PWRGD has been asserted high for the first time, the pin becomes a $\overline{\text{PWRDN}}$ (Power Down) pin that can be used to shut off all clocks cleanly and instruct the device to invoke power-saving mode. $\overline{\text{PWRDN}}$ is a completely asynchronous active low input. When entering power-saving mode, $\overline{\text{PWRDN}}$ should be asserted low prior to shutting off the input clock or power to ensure all clocks shut down in a glitch free manner. When $\overline{\text{PWRDN}}$ is asserted low, all clocks will be disabled prior to turning off the VCO. When $\overline{\text{PWRDN}}$ is deasserted high, all clocks will start and stop without any abnormal behavior and will meet all ac and dc parameters.

Note: The assertion and deassertion of $\overline{\text{PWRDN}}$ is absolutely asynchronous.

Warning: Disabling of the CLK_IN input clock prior to assertion of $\overline{\text{PWRDN}}$ is an undefined mode and not recommended. Operation in this mode may result in glitches, excessive frequency shifting, etc.

Table 13. PWRGD/PWRDN Functionality

$\overline{\text{PWRGD/PWRDN}}$	DIF	$\overline{\text{DIF}}$
0	Low	Low
1	Normal	Normal

2.5.1. $\overline{\text{PWRDN}}$ Assertion

When $\overline{\text{PWRDN}}$ is sampled low by two consecutive rising edges of $\overline{\text{DIF}}$, all differential outputs must be held LOW/LOW on the next $\overline{\text{DIF}}$ high-to-low transition.

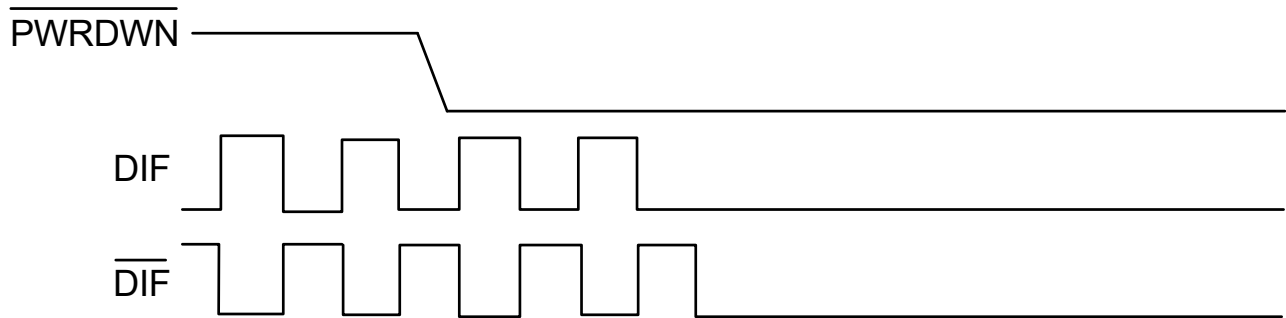

Figure 1. $\overline{\text{PWRDN}}$ Assertion

2.5.2. $\overline{\text{PWRGD}}$ Assertion

The power-up latency is to be less than 1.8 ms. This is the time from a valid CLK_IN input clock and the assertion of the $\overline{\text{PWRGD}}$ signal to the time that stable clocks are output from the device (PLL locked). All differential outputs stopped in a LOW/LOW condition resulting from power down must be driven high in less than 300 μs of $\overline{\text{PWRDN}}$ deassertion to a voltage greater than 200 mV.

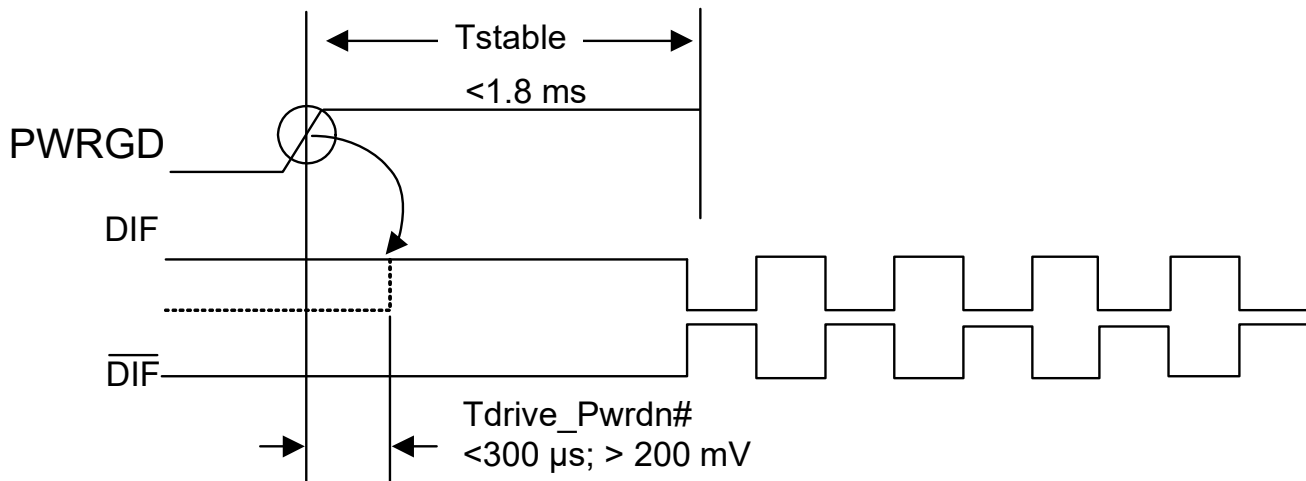

Figure 2. $\overline{\text{PWRGD}}$ Assertion (Pwrdown—Deassertion)

2.6. HBW_BYPASS_LBW

The HBW_BYPASS_LBW pin is a tri-level function input pin (refer to Table 14 for V_{IL_Tri} , V_{IM_Tri} , and V_{IH_Tri} signal levels). It is used to select between PLL high-bandwidth, PLL bypass mode, or PLL low-bandwidth mode. In PLL bypass mode, the input clock is passed directly to the output stage, which may result in up to 50 ps of additive cycle-to-cycle jitter (50 ps + input jitter) on the differential outputs. In the case of PLL mode, the input clock is passed through a PLL to reduce high-frequency jitter. The PLL HBW, BYPASS, and PLL LBW modes may be selected by asserting the HBW_BYPASS_LBW input pin to the appropriate level described in Table 14.

Table 14. PLL Bandwidth and Readback Table

HBW_BYPASS_LBW Pin	Mode	Byte 0, Bit 7	Byte 0, Bit 6
L	LBW	0	0
M	BYPASS	0	1
H	HBW	1	1

The Si53106 has the ability to override the latch value of the PLL operating mode from hardware strap pin 5 via the use of Byte 0 and bits 2 and 1. Byte 0 bit 3 must be set to 1 to allow the user to change Bits 2 and 1, affecting the PLL. Bits 7 and 6 will always read back the original latched value. A warm reset of the system will have to be accomplished if the user changes these bits.

2.7. Miscellaneous Requirements

Data Transfer Rate: 100 kbps (standard mode) is the base functionality required. Fast mode (400 kbps) functionality is optional.

Logic Levels: SMBus logic levels are based on a percentage of V_{DD} for the controller and other devices on the bus. Assume all devices are based on a 3.3 V supply.

Clock Stretching: The clock buffer must not hold/stretch the SCL or SDA lines low for more than 10 ms. Clock stretching is discouraged and should only be used as a last resort. Stretching the clock/data lines for longer than this time puts the device in an error/time-out mode and may not be supported in all platforms. It is assumed that all data transfers can be completed as specified without the use of clock/data stretching.

General Call: It is assumed that the clock buffer will not have to respond to the “general call.”

Electrical Characteristics: All electrical characteristics must meet the standard mode specifications found in Section 3 of the SMBus 2.0 specification.

Pull-Up Resistors: Any internal resistor pull-ups on the SDATA and SCLK inputs must be stated in the individual datasheet. The use of internal pull-ups on these pins of below 100 K is discouraged. Assume that the board designer will use a single external pull-up resistor for each line and that these values are in the 5–6 k Ω range. Assume one SMBus device per DIMM (serial presence detect), one SMBus controller, one clock buffer, one clock driver plus one/two more SMBus devices on the platform for capacitive loading purposes.

Input Glitch Filters: Only fast mode SMBus devices require input glitch filters to suppress bus noise. The clock buffer is specified as a standard mode device and is not required to support this feature. However, it is considered a good design practice to include the filters.

PWRDN: If a clock buffer is placed in PWRDN mode, the SDATA and SCLK inputs must be Tri-stated and the device must retain all programming information. IDD current due to the SMBus circuitry must be characterized and in the data sheet.

3. Test and Measurement Setup

3.1. Input Edge

Input edge rate is based on single-ended measurement. This is the minimum input edge rate at which the Si53106 is guaranteed to meet all performance specifications.

Table 15. Input Edge Rate

Frequency	Min	Max	Unit
100 MHz	0.35	N/A	V/ns
133 MHz	0.35	N/A	V/ns

3.1.1. Measurement Points for Differential

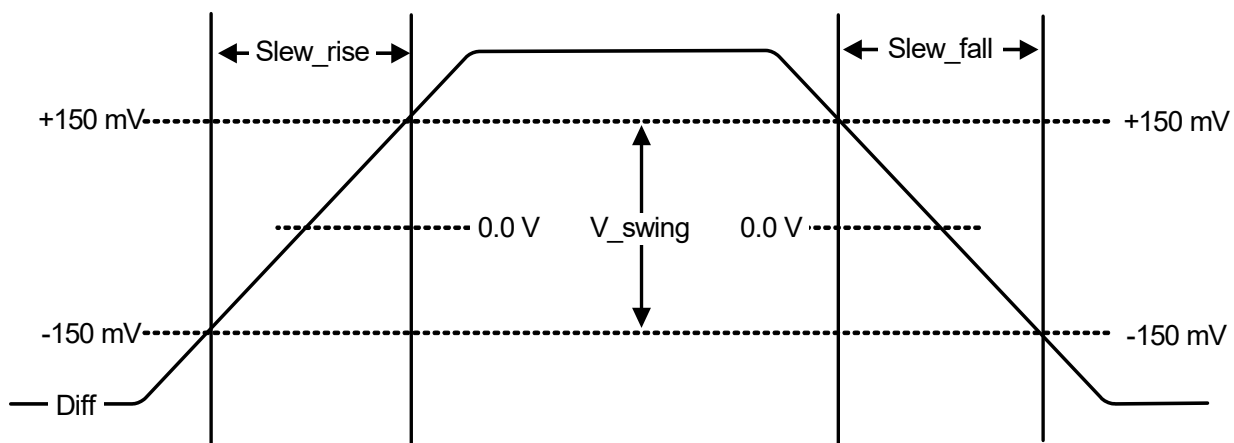

Figure 3. Measurement Points for Rise Time and Fall Time

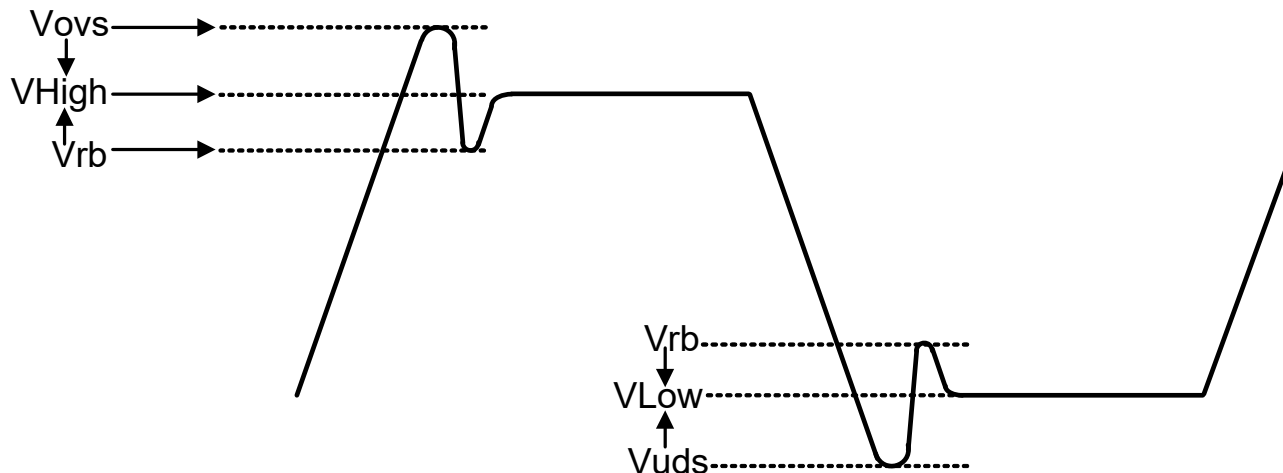

Figure 4. Single-Ended Measurement Points for V_{OVS} , V_{UDS} , V_{Rb}

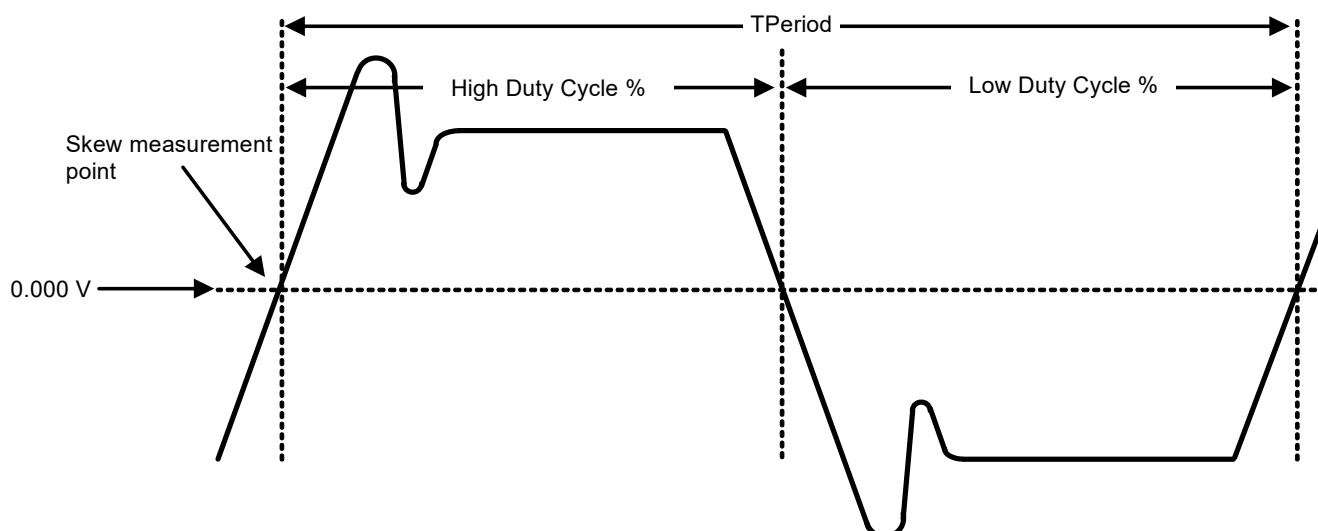

Figure 5. Differential (CLOCK-CLOCK) Measurement Points (T_{period} , Duty Cycle, Jitter)

3.2. Termination of Differential Outputs

All differential outputs are to be tested into a $100\ \Omega$ or $85\ \Omega$ differential impedance transmission line. Source terminated clocks have some inherent limitations as to the maximum trace length and frequencies that can be supported. For CPU outputs, a maximum trace length of 10" and a maximum of 200 MHz are assumed. For SRC clocks, a maximum trace length of 16" and maximum frequency of 100 MHz is assumed. For frequencies beyond 200 MHz, trace lengths must be restricted to avoid signal integrity problems.

Table 16. Differential Output Termination

Clock	Board Trace Impedance	R_s	R_p	Unit
DIFF Clocks— $50\ \Omega$ configuration	100	$33\pm 5\%$	N/A	Ω
DIFF Clocks— $43\ \Omega$ configuration	85	$27\pm 5\%$	N/A	Ω

3.2.1. Termination of Differential NMOS Push-Pull Type Outputs

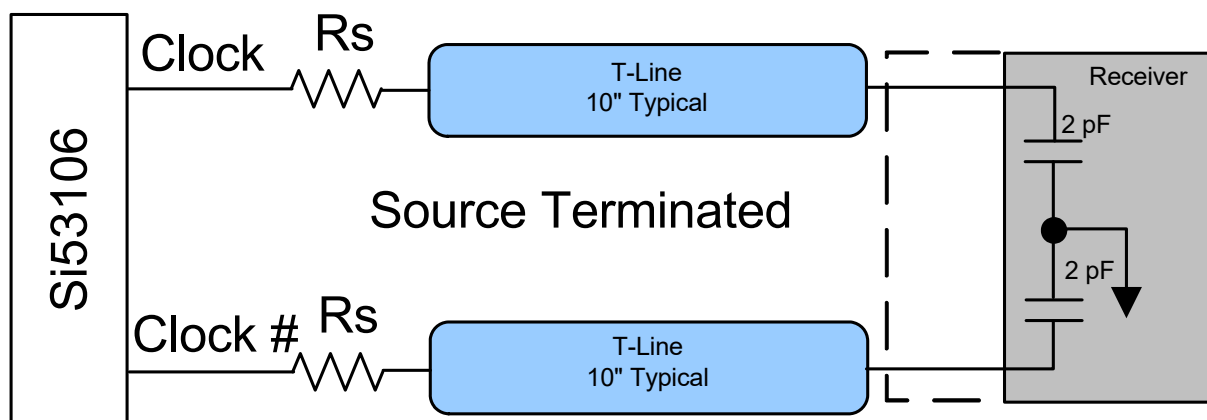

Figure 6. 0.7 V Configuration Test Load Board Termination for NMOS Push-Pull

4. Control Registers

4.1. Byte Read/Write

Reading or writing a register in an SMBus slave device in byte mode always involves specifying the register number.

4.1.1. Byte Read

The standard byte read is as shown in Figure 7. It is an extension of the byte write. The write start condition is repeated; then, the slave device starts sending data, and the master acknowledges it until the last byte is sent. The master terminates the transfer with a NAK, then a stop condition. For byte operation, the 2 x 7th bit of the command byte must be set. For block operations, the 2 x 7th bit must be reset. If the bit is not set, the next byte must be the byte transfer count.

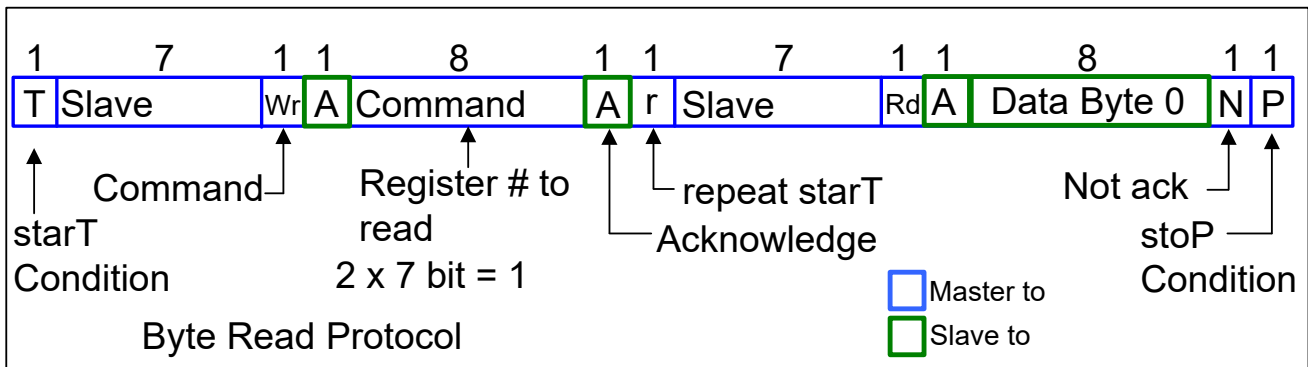

Figure 7. Byte Read Protocol

4.1.2. Byte Write

Figure 8 illustrates a simple, typical byte write. For byte operation, the 2 x 7th bit of the command byte must be set. For block operations, the 2 x 7th bit must be reset. If the bit is not set, the next byte must be the byte transfer count. The count can be between 1 and 32. It is not allowed to be zero or to exceed 32.

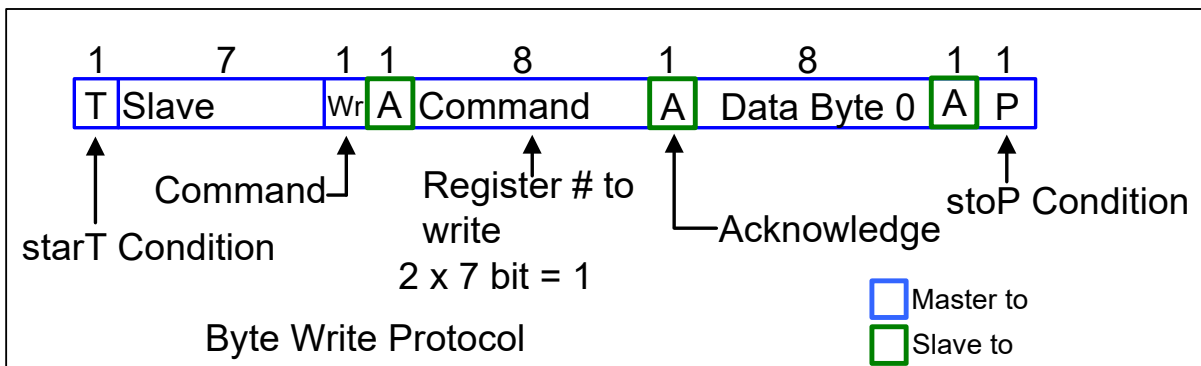

Figure 8. Byte Write Protocol

4.2. Block Read/Write

4.2.1. Block Read

After the slave address is sent with the R/W condition bit set, the command byte is sent with the MSB = 0. The slave acknowledges the register index in the command byte. The master sends a repeat start function. After the slave acknowledges this, the slave sends the number of bytes it wants to transfer (>0 and <33). The master acknowledges each byte except the last and sends a stop function.

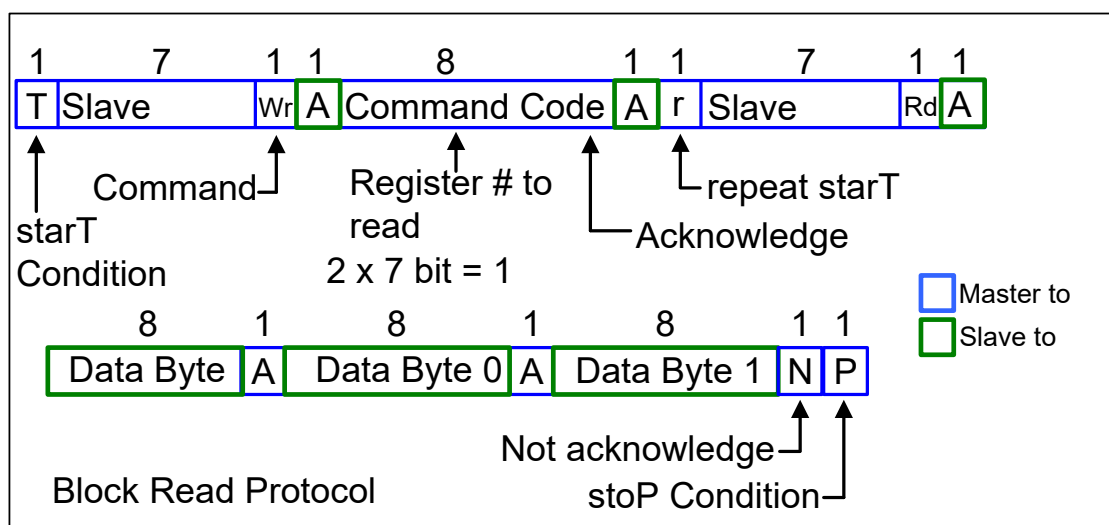

Figure 9. Block Read Protocol

4.2.2. Block Write

After the slave address is sent with the R/W condition bit not set, the command byte is sent with the MSB = 0. The lower seven bits indicate the register at which to start the transfer. If the command byte is 00h, the slave device will be compatible with existing block mode slave devices. The next byte of a write must be the count of bytes that the master will transfer to the slave device. The byte count must be greater than zero and less than 33. Following this byte are the data bytes to be transferred to the slave device. The slave device always acknowledges each byte received. The transfer is terminated after the slave sends the Ack and the master sends a stop function.

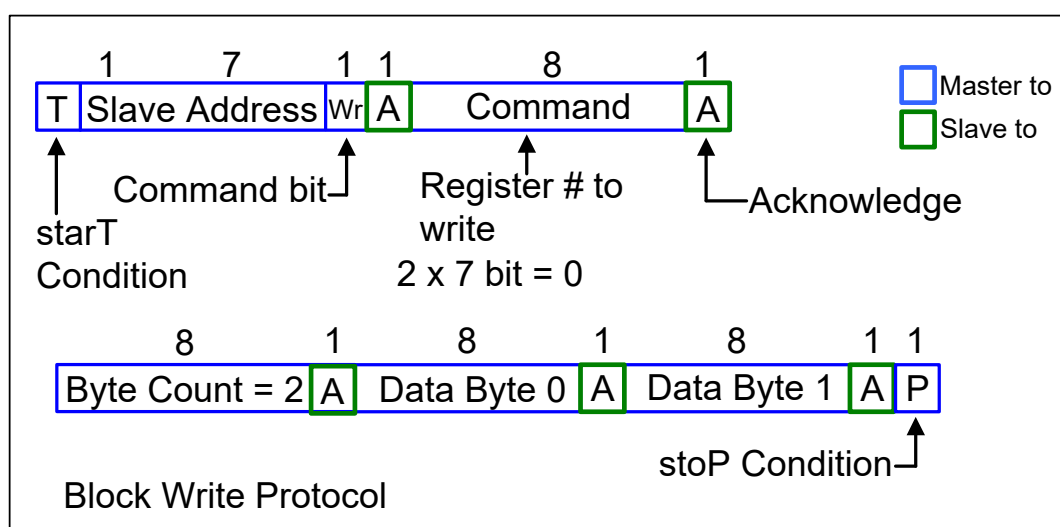

Figure 10. Block Write Protocol

4.3. Control Registers

Table 17. Byte 0: Frequency Select, Output Enable, PLL Mode Control Register

Bit	Description	If Bit = 0	If Bit = 1	Type	Default	Output(s) Affected
0	100M_133M# Frequency Select	133 MHz	100 MHz	R	Latched at power up	DIF[11:0]
1	PLL Mode 0	See PLL Operating Mode Readback Table		RW	1	
2	PLL Mode 1			RW	1	
3	PLL Software Enable	HW Latch	SMBUS Control	RW	0	
4	Reserved				0	
5	Reserved				0	
6	PLL Mode 0	See PLL Operating Mode Readback Table		R	Latched at power up	
7	PLL Mode 1	See PLL Operating Mode Readback Table		R	Latched at power up	

Note: Byte 0, bit_[3:1] are BW PLL SW enable for the DB1200ZL. Setting bit 3 to 1 allows the user to override the Latch value from pin 5 via use of bits 2 and 1. Use the values from the PLL Operating Mode Readback Table. Note that Bits 7 and 6 will keep the value originally latched on pin 5. A warm reset of the system will have to be accomplished if the user changes these bits.

Table 18. Byte 1: Output Enable Control Register

Bit	Description	If Bit = 0	If Bit = 1	Type	Default	Output(s) Affected
0	Reserved				0	
1	Output Enable DIF0	Low/Low	Enabled	RW	1	DIF0
2	Output Enable DIF1	Low/Low	Enabled	RW	1	DIF1
3	Reserved				0	
4	Reserved				0	
5	Output Enable DIF2	Low/Low	Enabled	RW	1	DIF2
6	Output Enable DIF3	Low/Low	Enabled	RW	1	DIF3
7	Reserved				0	

Table 19. Byte 2: Output Enable Control Register

Bit	Description	If Bit = 0	If Bit = 1	Type	Default	Output(s) Affected
0	Output Enable for DI4	Low/Low	Enabled	RW	1	DIF4
1	Reserved				0	
2	Output Enable for DI5	Low/Low	Enabled	RW	1	DIF5
3	Reserved				0	
4	Reserved				0	
5	Reserved				0	
6	Reserved				0	
7	Reserved				0	

Table 20. Byte 3: Reserved Control Register

Bit	Description	If Bit = 0	If Bit = 1	Type	Default	Output(s) Affected
0	Reserved				0	
1	Reserved				0	
2	Reserved				0	
3	Reserved				0	
4	Reserved				0	
5	Reserved				0	
6	Reserved				0	
7	Reserved				0	

Table 21. Byte 4: Reserved Control Register

Bit	Description	If Bit = 0	If Bit = 1	Type	Default	Output(s) Affected
0	Reserved				0	
1	Reserved				0	
2	Reserved				0	
3	Reserved				0	
4	Reserved				0	
5	Reserved				0	
6	Reserved				0	
7	Reserved				0	

Table 22. Byte 5: Vendor/Revision Identification Control Register

Bit	Description	If Bit = 0	If Bit = 1	Type	Default	Default
0	Vendor ID Bit 0			R	Vendor Specific	0
1	Vendor ID Bit 1			R	Vendor Specific	0
2	Vendor ID Bit 2			R	Vendor Specific	0
3	Vendor ID Bit 3			R	Vendor Specific	1
4	Revision Code Bit 0			R	Vendor Specific	0
5	Revision Code Bit 1			R	Vendor Specific	0
6	Revision Code Bit 2			R	Vendor Specific	0
7	Revision Code Bit 3			R	Vendor Specific	0

Table 23. Byte 6: Device ID Control Register

Bit	Description	If Bit = 0	If Bit = 1	Type	Default	Default
0	Device ID 0			R		0
1	Device ID 1			R		0
2	Device ID 2			R		0
3	Device ID 3			R		0
4	Device ID 4			R		0
5	Device ID 5			R		0
6	Device ID 6			R		0
7	Device ID 7 (MSB)			R		0

Table 24. Byte 7: Byte Count Register

Bit	Description	If Bit = 0	If Bit = 1	Type	Default	Output(s) Affected
0	BC0 - Writing to this register configures how many bytes will be read back			RW	0	
1	BC1 -Writing to this register configures how many bytes will be read back			RW	0	
2	BC2 -Writing to this register configures how many bytes will be read back			RW	0	
3	BC3 -Writing to this register configures how many bytes will be read back			RW	1	
4	BC4 -Writing to this register configures how many bytes will be read back			RW	0	
5	Reserved				0	
6	Reserved				0	
7	Reserved				0	

Si53106

6. Pin Descriptions: 40-Pin QFN

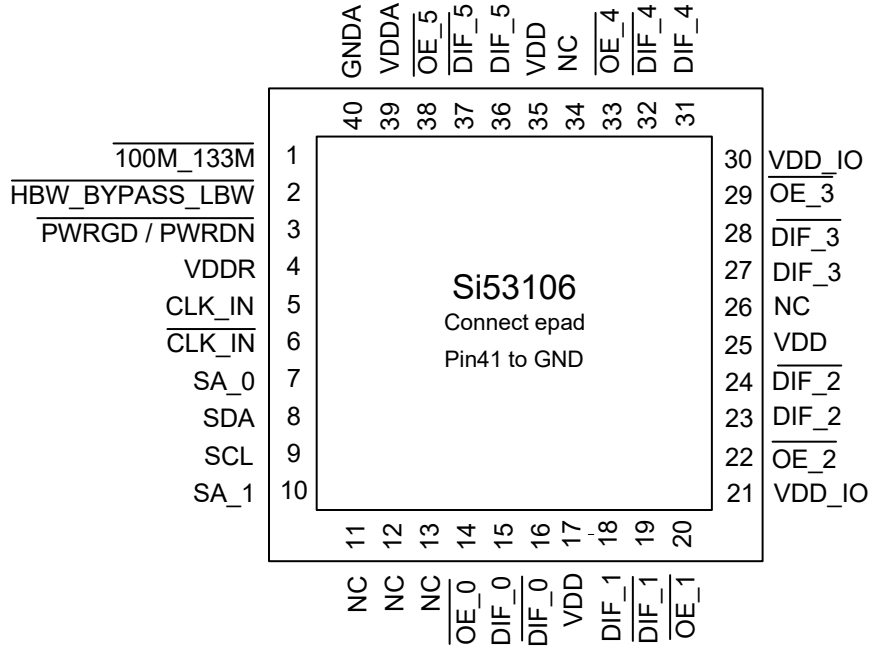

Table 25. Si53106 40-Pin QFN Descriptions

Pin #	Name	Type	Description
1	$\overline{100M_133M}$	I,SE	3.3 V tolerant inputs for input/output frequency selection. An external pull-up or pull-down resistor is attached to this pin to select the input/output frequency. High = 100 MHz output Low = 133 MHz output
2	$\overline{HBW_BYPASS_LBW}$	I, SE	Tri-Level input for selecting the PLL bandwidth or bypass mode. High = High BW mode Med = Bypass mode Low = Low BW mode
3	$\overline{PWRGD/PWRDN}$	I	3.3 V LVTTTL input to power up or power down the device.
4	VDDR	VDD	3.3 V power supply for differential input receiver. This VDDR should be treated as an analog power rail and filtered appropriately.
5	CLK_IN	I, DIF	0.7 V Differential input.
6	$\overline{CLK_IN}$	I, DIF	0.7 V Differential input.
7	SA_0	I,PU	3.3 V LVTTTL input selecting the address. Tri-level input.
8	SDA	I/O	Open collector SMBus data.
9	SCL	I/O	SMBus slave clock input.
10	SA_1	I,PU	3.3 V LVTTTL input selecting the address. Tri-level input.
11	NC	I/O	No connect. There are active signals on pin 11 and 12, do not connect anything to these pins.
12	NC	I/O	No connect. There are active signals on pin 11 and 12, do not connect anything to these pins.
13	NC	-	Do not connect this pin to anything.
14	$\overline{OE_0}$	I, SE	3.3 V LVTTTL active low input for enabling differential outputs (default). Controls the corresponding output pair. Internal pull-down.
15	DIF_0	O, DIF	0.7 V Differential clock output. Default is 1:1.
16	$\overline{DIF_0}$	O, DIF	0.7 V Differential clock output. Default is 1:1.
17	VDD	3.3 V	3.3 V power supply for outputs.
18	DIF_1	O, DIF	0.7 V Differential clock output. Default is 1:1.
19	$\overline{DIF_1}$	O, DIF	0.7 V Differential clock output. Default is 1:1.
20	$\overline{OE_1}$	I, SE	3.3 V LVTTTL active low input for enabling differential outputs (default). Controls the corresponding output pair. Internal pull-down.
21	VDD_IO	VDD	Power supply for differential outputs.
22	$\overline{OE_2}$	I, SE	3.3 V LVTTTL active low input for enabling differential outputs (default). Controls the corresponding output pair. Internal pull-down.
23	DIF_2	O, DIF	0.7 V Differential clock outputs. Default is 1:1.

Table 25. Si53106 40-Pin QFN Descriptions

Pin #	Name	Type	Description
24	$\overline{\text{DIF}}_2$	O, DIF	0.7 V Differential clock output. Default is 1:1.
25	VDD	3.3 V	3.3 V power supply for output.
26	NC	-	Do not connect this pin to anything.
27	DIF_3	O, DIF	0.7 V Differential clock output. Default is 1:1.
28	$\overline{\text{DIF}}_3$	O, DIF	0.7 V Differential clock output. Default is 1:1.
29	$\overline{\text{OE}}_3$	I, SE	3.3 V LVTTTL active low input for enabling differential outputs (default). Controls the corresponding output pair. Internal pull-down.
30	VDD_IO	VDD	Power supply for differential outputs.
31	DIF_4	O, DIF	0.7 V Differential clock output. Default is 1:1.
32	$\overline{\text{DIF}}_4$	O, DIF	0.7 V Differential clock output. Default is 1:1.
33	$\overline{\text{OE}}_4$	I, SE	3.3 V LVTTTL active low input for enabling differential outputs (default). Controls the corresponding output pair. Internal pull-down.
34	NC	-	Do not connect this pin to anything.
35	VDD	3.3 V	3.3 V power supply for outputs.
36	DIF_5	O, DIF	0.7 V Differential clock output. Default is 1:1.
37	$\overline{\text{DIF}}_5$	O, DIF	0.7 V Differential clock output. Default is 1:1.
38	$\overline{\text{OE}}_5$	I, SE	3.3 V LVTTTL active low input for enabling differential outputs (default). Controls the corresponding output pair. Internal pull-down.
39	VDDA	3.3 V	3.3 V power supply for outputs.
40	GND_A	GND	Ground for outputs.
41	GND	GND	Connect epad to ground.

7. Ordering Guide

Part Number	Package Type	Temperature
Lead-free		
Si53106-A01AGM	40-pin QFN	Extended, –40 to 85 °C
Si53106-A01AGMR	40-pin QFN—Tape and Reel	Extended, –40 to 85 °C

8. Package Outline

Figure 12 illustrates the package details for the Si53106. Table 26 lists the values for the dimensions shown in the illustration.

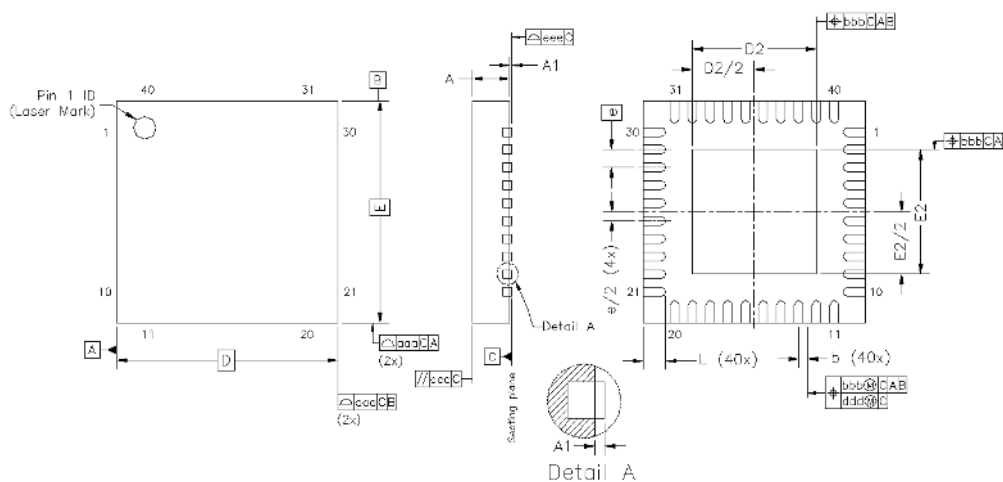

Figure 12. 40-Pin Quad Flat No Lead (QFN) Package

Table 26. Package Diagram Dimensions

Dimension	Min	Nom	Max
A	0.80	0.85	0.90
A1	0.00	0.02	0.05
b	0.15	0.20	0.25
D	5.00 BSC.		
D2	2.65	2.80	2.95
e	0.40 BSC.		
E	5.00 BSC.		
E2	2.65	2.80	2.95
L	0.30	0.40	0.50
aaa	0.10		
bbb	0.07		
ccc	0.1		
ddd	0.05		
eee	0.08		
Notes:			
1. All dimensions shown are in millimeters (mm) unless otherwise noted.			
2. Dimensioning and Tolerancing per ANSI Y14.5M-1994.			
3. This drawing conforms to JEDEC outline MO-220			

9. Land Pattern

Figure 13 illustrates the recommended land pattern details for the Si53106 in a 40-pin QFN package. Table 27 lists the values for the dimensions shown in the illustration.

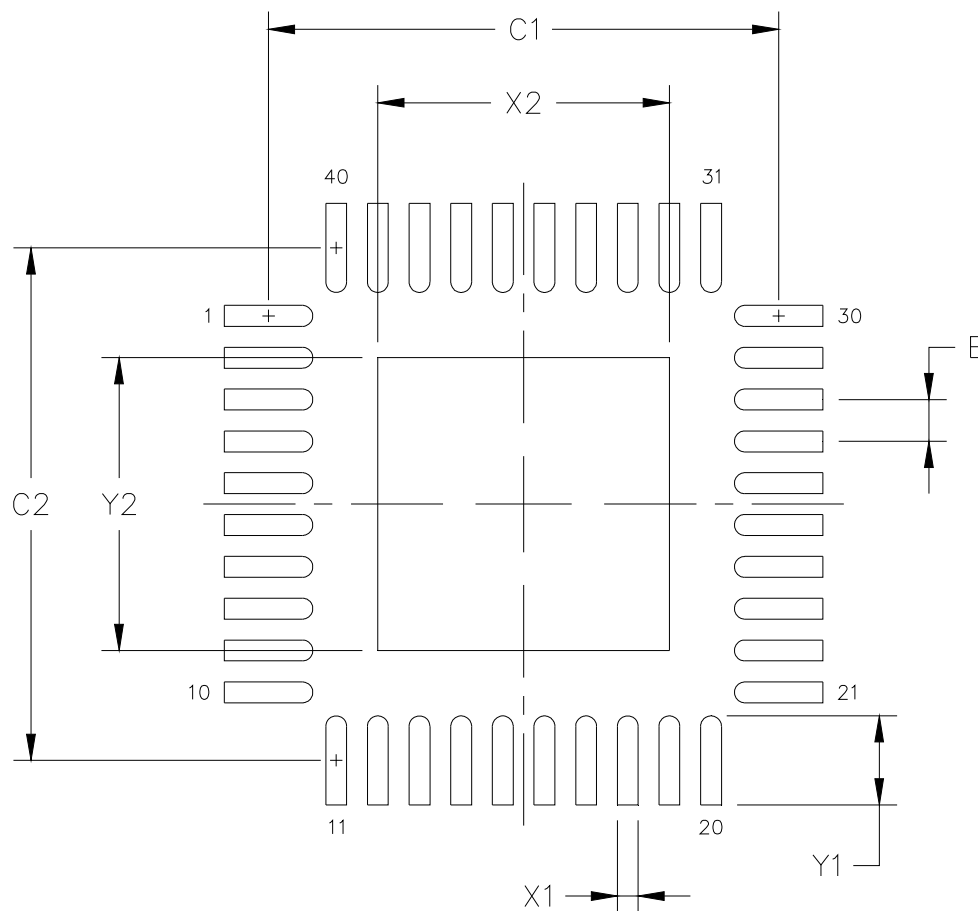

Figure 13. Land Pattern

Table 27. PCB Land Pattern Dimensions

Dimension	Min	Max
C1	4.80	4.90
C2	4.80	4.90
E	0.40 BSC	
X1	0.15	0.20
X2	2.85	2.95
Y1	0.75	0.85
Y2	2.85	2.95

Notes:

General

1. All dimensions shown are in millimeters (mm) unless otherwise noted.
2. This Land Pattern Design is based on the IPC-7351 guidelines.

Solder Mask Design

3. All metal pads are to be non-solder mask defined (NSMD). Clearance between the solder mask and the metal pad is to be 60 μm minimum, all the way around the pad.

Stencil Design

4. A stainless steel, laser-cut and electro-polished stencil with trapezoidal walls should be used to assure good solder paste release.
5. The stencil thickness should be 0.125 mm (5 mils).
6. The ratio of stencil aperture to land pad size should be 1:1 for all perimeter pads.
7. A 2x2 array of 1.0 mm square openings on a 1.4 mm pitch should be used for the center ground pad.

Card Assembly

8. A No-Clean, Type-3 solder paste is recommended.
9. The recommended card reflow profile is per the JEDEC/IPC J-STD-020 specification for Small Body Components.

DOCUMENT CHANGE LIST

Revision 1.1 to Revision 1.2

- Updated Features on page 1.
- Updated Description on page 1.
- Updated specs in Table 5, "Phase Jitter," on page 7.



SKYWORKS®

ClockBuilder Pro

Customize Skyworks clock generators, jitter attenuators and network synchronizers with a single tool. With CBPro you can control evaluation boards, access documentation, request a custom part number, export for in-system programming and more!

www.skyworksinc.com/CBPro



Portfolio

www.skyworksinc.com/ia/timing



SW/HW

www.skyworksinc.com/CBPro

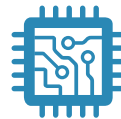

Quality

www.skyworksinc.com/quality



Support & Resources

www.skyworksinc.com/support

Copyright © 2021 Skyworks Solutions, Inc. All Rights Reserved.

Information in this document is provided in connection with Skyworks Solutions, Inc. ("Skyworks") products or services. These materials, including the information contained herein, are provided by Skyworks as a service to its customers and may be used for informational purposes only by the customer. Skyworks assumes no responsibility for errors or omissions in these materials or the information contained herein. Skyworks may change its documentation, products, services, specifications or product descriptions at any time, without notice. Skyworks makes no commitment to update the materials or information and shall have no responsibility whatsoever for conflicts, incompatibilities, or other difficulties arising from any future changes.

No license, whether express, implied, by estoppel or otherwise, is granted to any intellectual property rights by this document. Skyworks assumes no liability for any materials, products or information provided hereunder, including the sale, distribution, reproduction or use of Skyworks products, information or materials, except as may be provided in Skyworks' Terms and Conditions of Sale.

THE MATERIALS, PRODUCTS AND INFORMATION ARE PROVIDED "AS IS" WITHOUT WARRANTY OF ANY KIND, WHETHER EXPRESS, IMPLIED, STATUTORY, OR OTHERWISE, INCLUDING FITNESS FOR A PARTICULAR PURPOSE OR USE, MERCHANTABILITY, PERFORMANCE, QUALITY OR NON-INFRINGEMENT OF ANY INTELLECTUAL PROPERTY RIGHT; ALL SUCH WARRANTIES ARE HEREBY EXPRESSLY DISCLAIMED. SKYWORKS DOES NOT WARRANT THE ACCURACY OR COMPLETENESS OF THE INFORMATION, TEXT, GRAPHICS OR OTHER ITEMS CONTAINED WITHIN THESE MATERIALS. SKYWORKS SHALL NOT BE LIABLE FOR ANY DAMAGES, INCLUDING BUT NOT LIMITED TO ANY SPECIAL, INDIRECT, INCIDENTAL, STATUTORY, OR CONSEQUENTIAL DAMAGES, INCLUDING WITHOUT LIMITATION, LOST REVENUES OR LOST PROFITS THAT MAY RESULT FROM THE USE OF THE MATERIALS OR INFORMATION, WHETHER OR NOT THE RECIPIENT OF MATERIALS HAS BEEN ADVISED OF THE POSSIBILITY OF SUCH DAMAGE.

Skyworks products are not intended for use in medical, lifesaving or life-sustaining applications, or other equipment in which the failure of the Skyworks products could lead to personal injury, death, physical or environmental damage. Skyworks customers using or selling Skyworks products for use in such applications do so at their own risk and agree to fully indemnify Skyworks for any damages resulting from such improper use or sale.

Customers are responsible for their products and applications using Skyworks products, which may deviate from published specifications as a result of design defects, errors, or operation of products outside of published parameters or design specifications. Customers should include design and operating safeguards to minimize these and other risks. Skyworks assumes no liability for applications assistance, customer product design, or damage to any equipment resulting from the use of Skyworks products outside of Skyworks' published specifications or parameters.

Skyworks, the Skyworks symbol, Sky5®, SkyOne®, SkyBlue™, Skyworks Green™, Clockbuilder®, DSPLL®, ISOModem®, ProSLIC®, and SiPHY® are trademarks or registered trademarks of Skyworks Solutions, Inc. or its subsidiaries in the United States and other countries. Third-party brands and names are for identification purposes only and are the property of their respective owners. Additional information, including relevant terms and conditions, posted at www.skyworksinc.com, are incorporated by reference.

Skyworks Solutions, Inc. | Nasdaq: SWKS | sales@skyworksinc.com | www.skyworksinc.com

USA: 781-376-3000 | Asia: 886-2-2735 0399 | Europe: 33 (0)1 43548540 | 