

**SF2002B-2**

**942.5 MHz  
SAW Filter**

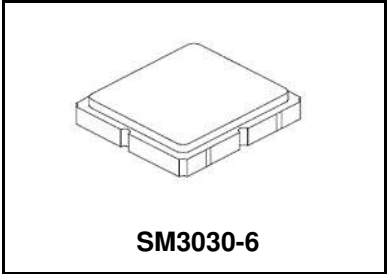

- **RF Filter for EGSM**
- **High Attenuation Design**
- **No Matching Circuit Required**
- **3.0 x 3.0 x 1.3 mm Package**
- **Complies with directive 2002/95/EC (RoHS)**
- **Moisture Sensitivity Level: 1**

**Absolute Maximum Ratings**

Rating	Value	Units
Maximum Input Power	+15	dBm
DC voltage between Terminals	-3 ~ +3	VDC
Operating Temperature	-30 to +80	°C

**Electrical Characteristics**

Characteristic	Sym	Notes	Min	Typ	Max	Units
Nominal Operating Frequency	$f_c$			942.5		MHz
Passband		Insertion Loss (925~960 MHz)		2.8	4.0	dB
		Amplitude Ripple (925~960 MHz)		1.1	2.3	dB
Attenuation (Reference level from 0 dB)						
		10~800 MHz	50	63		dB
		800~880 MHz	40	48		dB
		880~905 MHz	35	43		dB
		980~982 MHz	20	27		dB
		982~1005 MHz	23	28		dB
		1005~1025 MHz	29	33		dB
		1025~1760 MHz	40	50		dB
		1760~2300 MHz	30	41		dB
		2300~3000 MHz	20	28		dB
Input $Z_{IN}$				50		$\Omega$
Output $Z_{OUT}$				50		$\Omega$
Case Style	SM3030-6 3 x 3 mm Nominal Footprint					
Lid Symbolization (Y=year, WW=week, S=Shift)	464, <u>YWWS</u>					

**Electrical Connections**

Connection	Terminals
Input	2
Output	5
Ground	All others

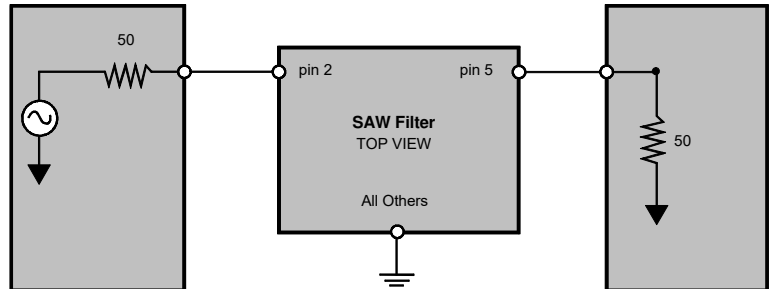

**CAUTION: Electrostatic Sensitive Device. Observe precautions for handling.**

**NOTES:**

1. The design, manufacturing process, and specifications of this device are subject to change.
2. US or International patents may apply.
3. RoHS compliant from the first date of manufacture.

## FREQUENCY CHARACTERISTICS:

### 1. wideband response:

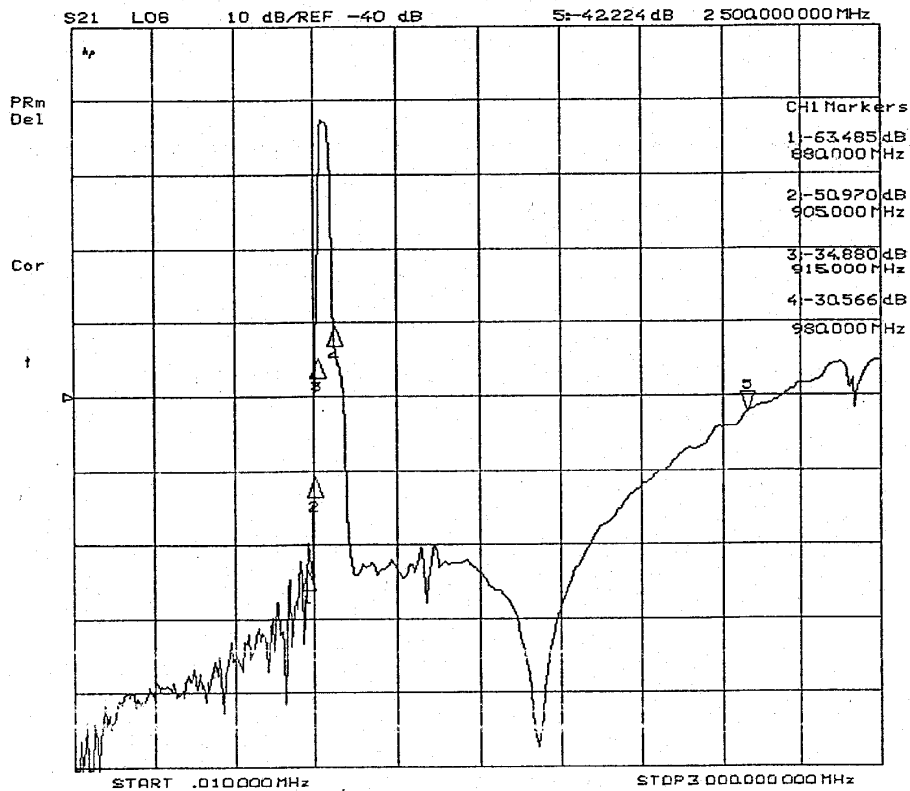
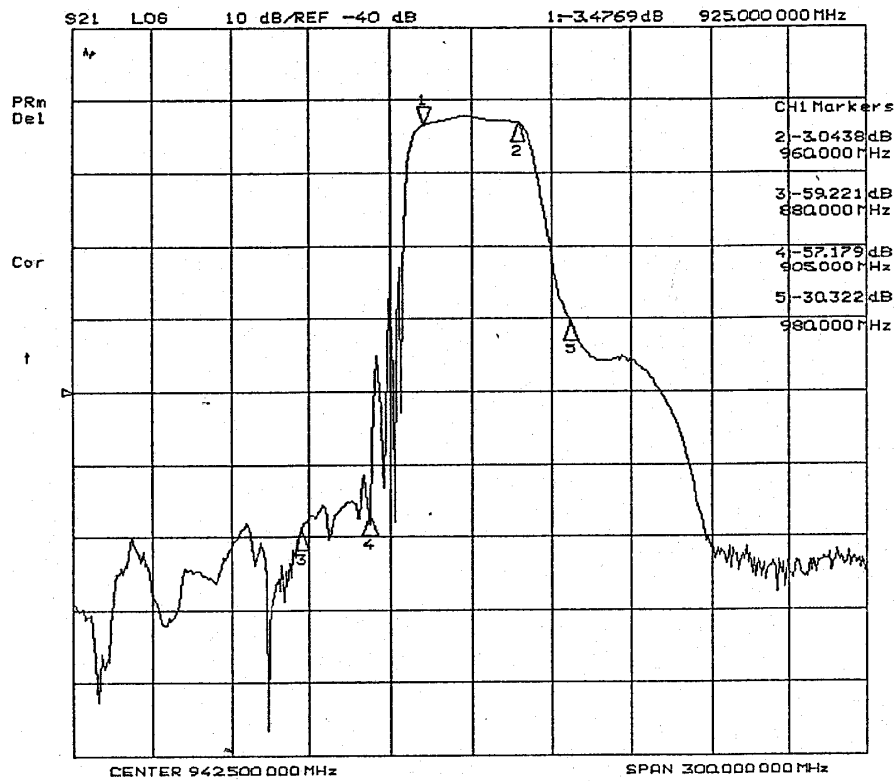

## S11 Return Loss & VSWR:

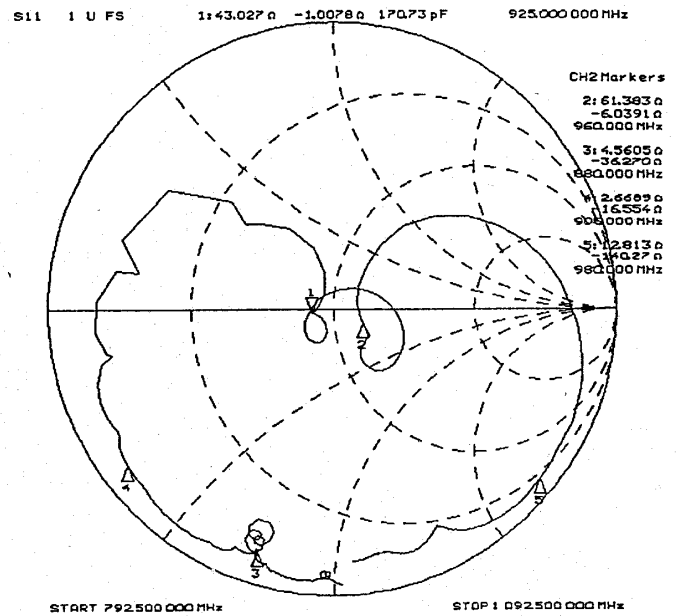
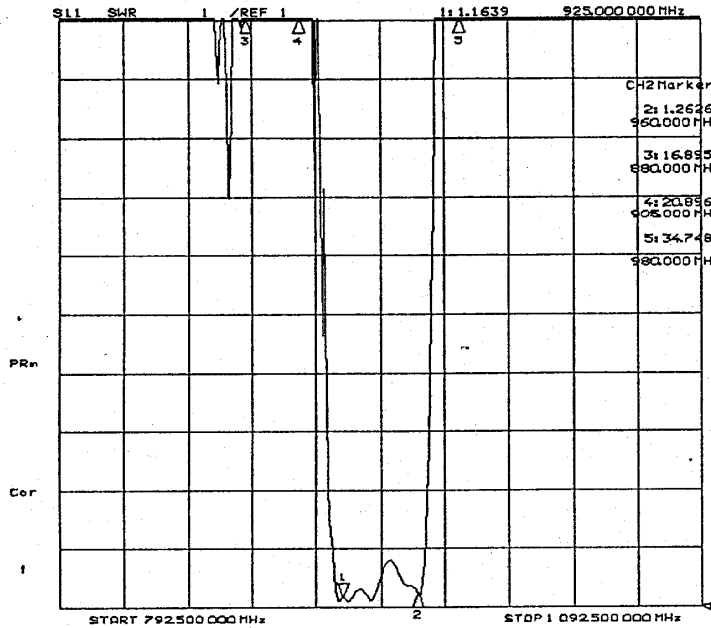

## S22 Return Loss & VSWR:

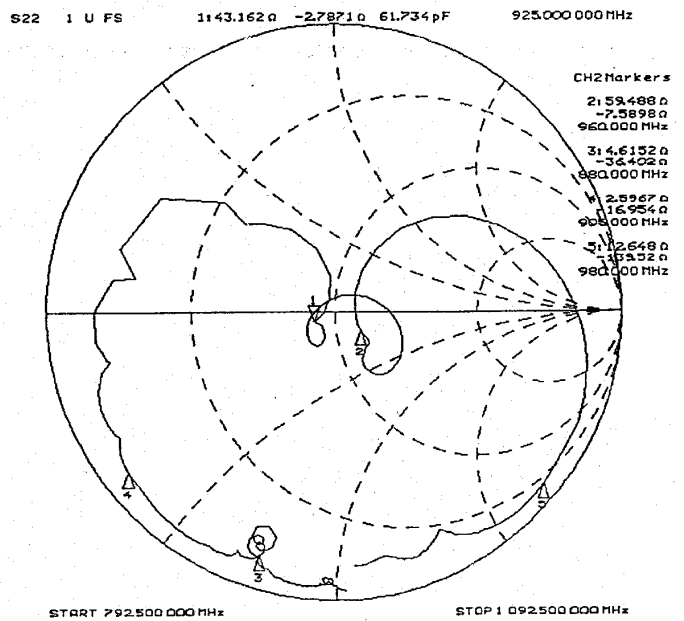
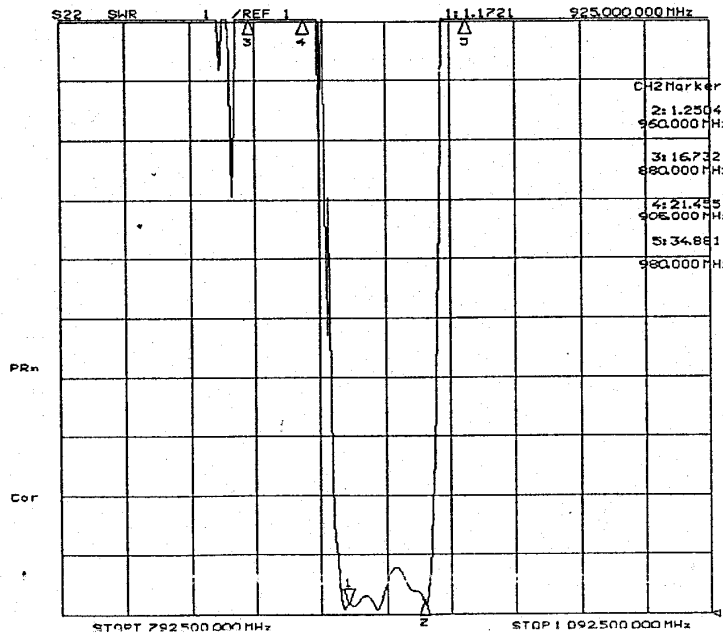

## Tape and Reel Specifications

Tape and Reel Standard per ANSI/EIA481

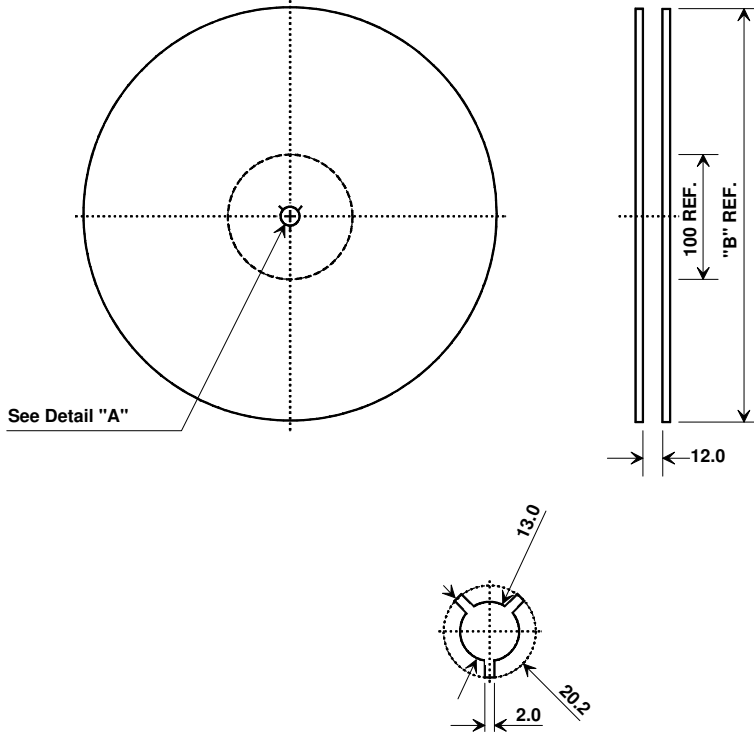

"B "		Quantity Per Reel
Nominal Size		
Inches	millimeters	
7	178	500
13	330	3000

### COMPONENT ORIENTATION

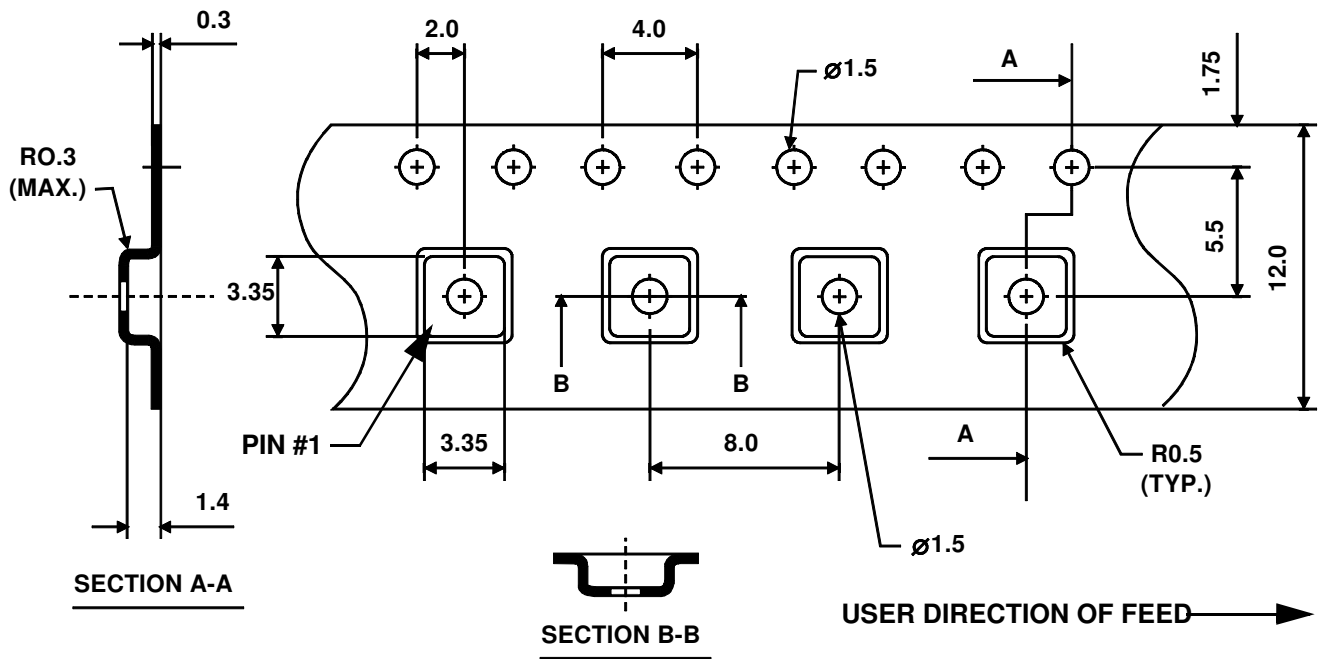

SM3030-6 Case

6-Terminal Ceramic Surface-Mount Case  
3.0 X 3.0 mm Nominal Footprint

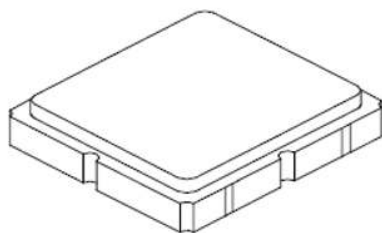

Case Dimensions

Dimension	mm			Inches		
	Min	Nom	Max	Min	Nom	Max
A		3.0			0.118	
B		3.0			0.118	
C		1.3			0.051	
D		0.9			0.035	
E		2.54			0.100	
F		1.6			0.063	
G		0.85			0.033	
H		1.5			0.059	
I		0.6			0.024	
J		1.3			0.051	

Electrical Connections

Connection		Terminals
Port 1	Single Ended Input	2
Port 2	Single Ended Output	5
	Ground	All others
<b>Single Ended Operation Only</b>		
Dot indicates Pin 1		

TOP VIEW

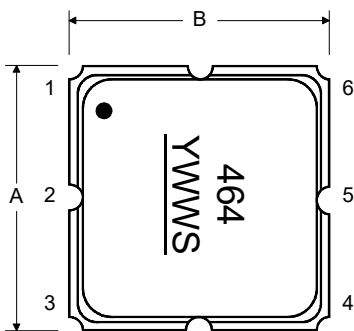

BOTTOM VIEW

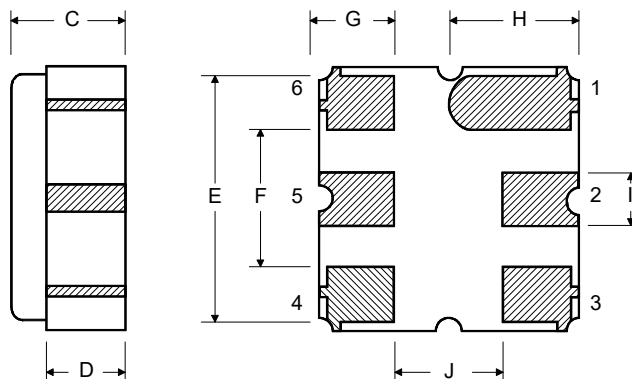

## Recommended Reflow Profile

1. Preheating shall be fixed at 150~180° for 60~90 seconds.
2. Ascending time to preheating temperature 150° shall be 30 seconds min.
3. Heating shall be fixed at 220°C for 50~80 seconds and at 260°C peak (10 seconds.)
4. Time: 5 times maximum

