

# VON1k5Vm

## Ultrafast, 1000V, Single Supply, Bidirectional ON-State Voltage (V-ON) Sensor



### 1. Description

The Tell-i Technologies VON1k5m is a state-of-the-art sensor developed to measure the drain-to-source voltage of high voltage power MOSFETs with high resolution during ON-state. It can be also used to measure the collector-emitter of IGBTs during ON-state. The sensor clamps the high voltage drain-to-source/collector-to-emitter potential at +2.8V during the OFF-state. Once ON-state occurs, the V-ON sensor provides  $V_{DSON}$  measurements within the fast rise/fall times of 50ns-200nsec. On-state voltage and its derivatives can be used for health monitoring and prognostics of power converters at the level of semiconductor power devices. The VON1kV5m sensor addresses the need for quick and accurate voltage sensing in power electronics using wide-bandgap devices. The VON1kV5m sensor operates using a single supply of +5V making its integration into control systems seamless.

The VON1kV5Vm sensor is ideal for in-situ instrumentation to monitor and predict the performance of power electronics devices and systems at the level of power semiconductor device. The ON-state voltage along with the current information captures necessary parameters to estimate and monitor the resistance of high voltage power semiconductor devices.

With 50-200 nanosecond settling time and 1000V blocking voltage capability, the VON sensor can be used for high frequency high voltage power electronics using wide bandgap devices such as silicon carbide (SiC) and gallium nitride (GaN) transistors. With such a short settling time, dynamic on-resistance especially important for GaN power devices can be estimated within 300 nanoseconds after switching transients.



### Features

- Ultrafast 50ns-200ns Settling time
- Up to 1000V blocking voltage range
- Built-in temperature variation compensation
- Low power consumption
- Single supply Voltage: 5V
- Non-invasive
- No set/reset or control requirements

### 2. Applications

- Health monitoring and prognostics
- In-situ instrumentation of power electronics
- Dynamic  $R_{DSON}$  measurement/characterization
- Automotive
- Aerospace
- Artificial intelligence (AI)
- Datacenters
- Solar PV/ Battery Inverters



Order  
Online

Version updated on November 10, 2022.

Copyright © 2022 Tell-i Technologies Inc.

### 3. Main Characteristics

Stresses above these ratings may cause permanent damage. In addition, exposure to absolute maximum conditions for extended periods may degrade device reliability. These are stress ratings only, and functional operation at these or other conditions beyond those specified is not implied.

Parameters	Conditions	Min	Typical	Max	Units
Supply Voltage ( $V_{CC}$ )	Operating	-	5	-	V
Sensor Quiescent Current		-	25	-	mA
Settling Time		50	100 <sup>1</sup>	200 <sup>2</sup>	ns
Off-State Voltage		-	2.8	3.2	V
Operating Bus Voltage		-	400	1000	V
Operating Temperature	Case max. temperature	-	25	80	°C

### 4. Functional Block Diagram

The VON1k5Vm operates by capturing the  $V_{DS(on)}$  of a switching device, a very small potential present across the drain and source terminals of the transistor when active. During the OFF-state, a constant voltage of 2.8V is present at the VON output. During the ON-state, the voltage at the input terminal is subtracted by the voltage drop across the drain-side diode to acquire the  $V_{DS(on)}$  value. A filter network is present to reduce the interference of noise and ringing's present during the switching cycle. The diagram below has been created to help explain this process.

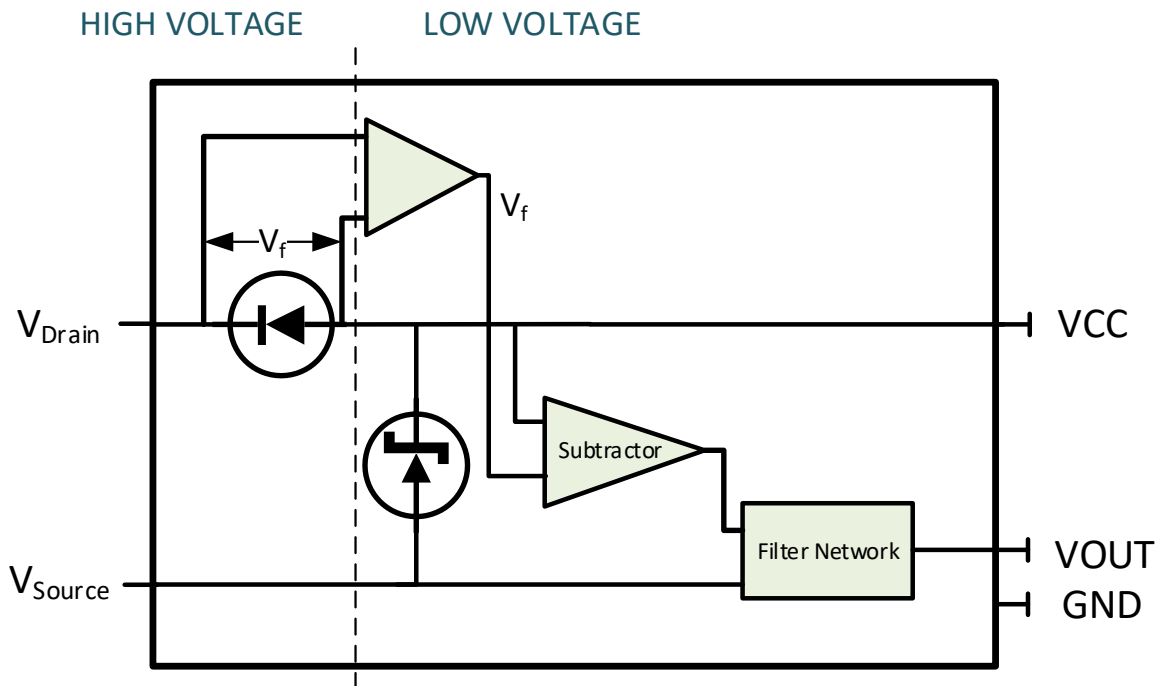

<sup>1</sup>Value captured using a GaN double-pulse test <400V

<sup>2</sup>Value captured using a SiC double-pulse test at 800V

## 5. Typical Circuit

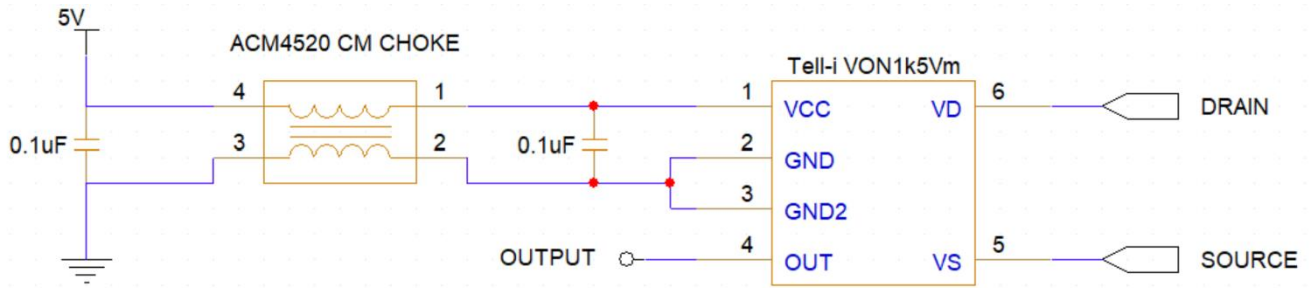

## 6. Example of Performance

(DYNAMIC)  $R_{DS(ON)}$  CALCULATION USING ON-STATE VOLTAGE SENSOR (VON)

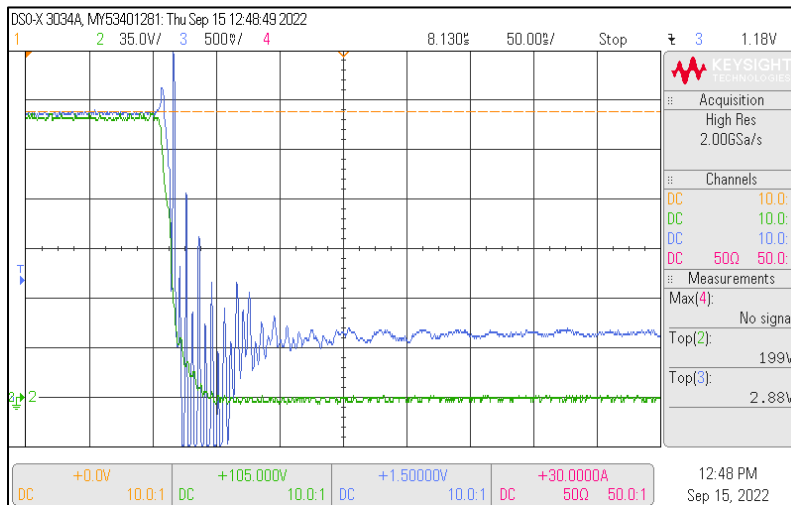
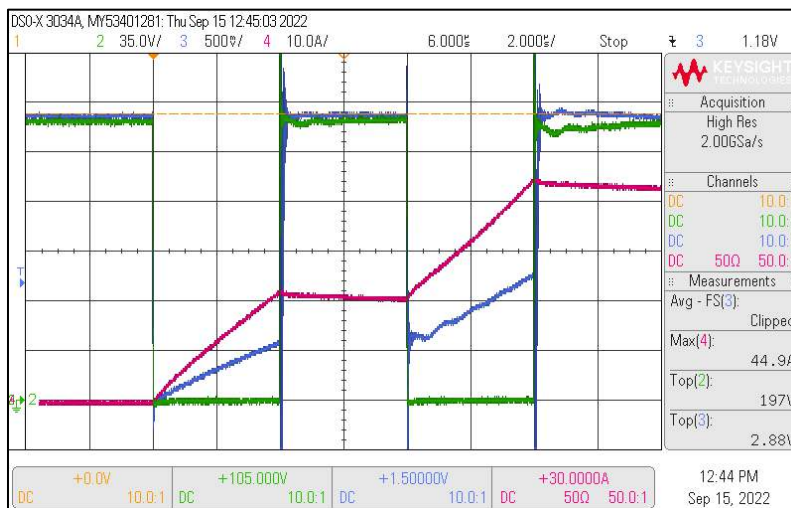

Figure: Double-pulse test: 200VDC, 45A. Green trace: Drain-Source Voltage. Blue trace: Tell-i VON1k5Vm output. Magenta trace: Inductor current. Tell-i VON1k5Vm settlement time: <50nsec. The device under test: GaN GS6651B.

On-Resistance Calculation:

The  $V_{DSON}$  value is given by the output of the VON sensor. The dynamic on-resistance can then be calculated using Ohm's Law:

$$R_{DSON} = \frac{V_{DSON}}{I_D}$$

where  $I_D$  is the current through the device under test (DUT).

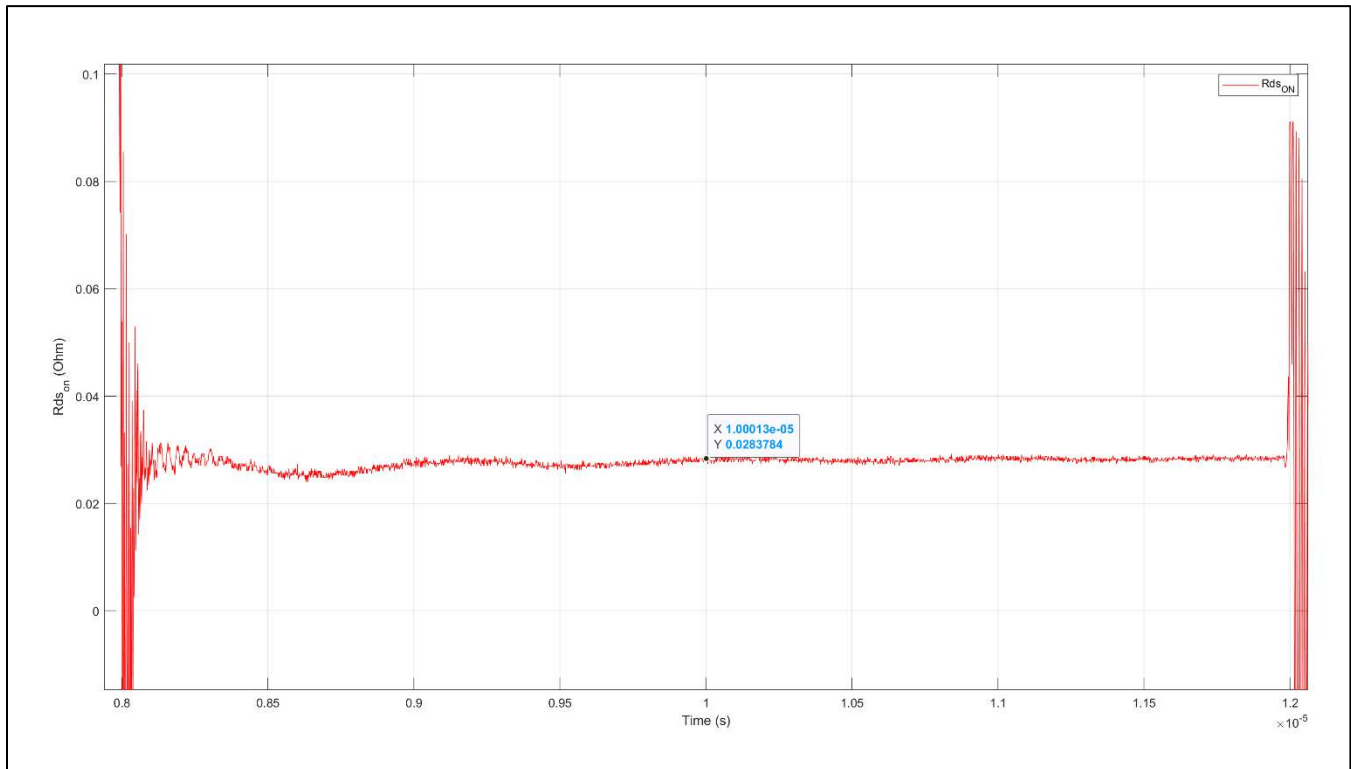

Figure: Red trace: 2<sup>nd</sup> Pulse  $R_{DSON}$  measurement of DUT. The device under test: GaN Systems 650V GaN GS6651B approximate  $R_{DSON} \approx 25m\Omega$ . Tell-i VON1k5Vm  $R_{DSON} \approx 28m\Omega$ .

## 7. Package Dimensions

### a. VON1k5Vm – Surface Mount Module

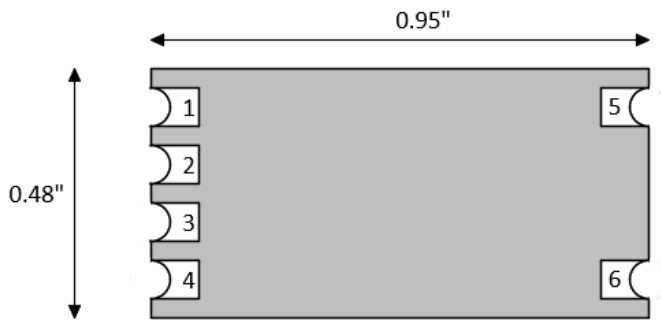

Figure. Bottom footprint: 0.95" x 0.48"

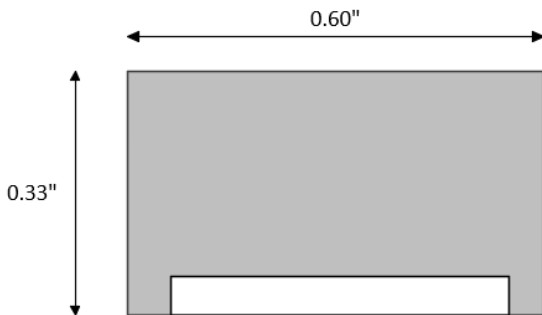

Figure. Side view: 0.60" x 0.33"

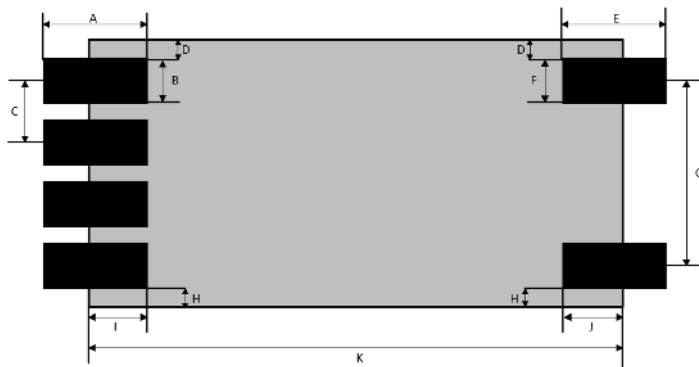

Figure. Bottom footprint with pad measurements for hand-soldering

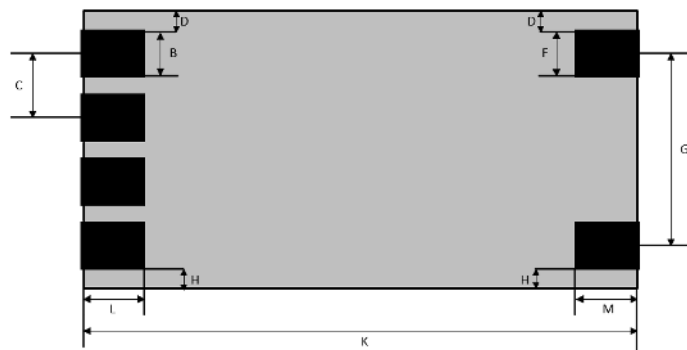

Figure. Bottom footprint with pad measurements for reflow-soldering

Pin	Function
1	VCC (5V)
2	GND
3	GND
4	VOUT
5	DRAIN
6	SOURCE

Symbol	Inches	Millimeters
A	0.140	3.556
B	0.080	2.032
C	0.100	2.54
D	0.050	1.27
E	0.140	3.556
F	0.100	2.54
G	0.300	7.62
H	0.050	1.27
I	0.080	2.032
J	0.100	2.54
K	0.950	24.13
L	0.070	1.778
M	0.090	2.286