

# TFT LCD Approval Specification

**MODEL NO.: PQ 3Qi-01**

Customer: \_\_\_\_\_

Approved by: \_\_\_\_\_

Note:

CONTENTS

<b>1</b>	<b>GENERAL DESCRIPTION.....</b>	<b>5</b>
1.1	OVERVIEW .....	5
1.2	FEATURES .....	5
1.3	APPLICATIONS .....	5
1.4	GENERAL SPECIFICATIONS.....	5
1.5	MECHANICAL SPECIFICATIONS.....	5
<b>2</b>	<b>ABSOLUTE MAXIMUM RATINGS.....</b>	<b>7</b>
2.1	ABSOLUTE MAXIMUMS, ENVIRONMENTAL.....	7
2.2	ABSOLUTE MAXIMUMS, ELECTRICAL.....	8
2.2.1	TFT LCD MODULE .....	8
2.2.2	BACKLIGHT CONVERTER INPUT.....	8
2.2.3	LED LIGHT BAR UNIT.....	8
<b>3</b>	<b>ELECTRICAL CHARACTERISTICS.....</b>	<b>9</b>
3.1	FUNCTIONAL BLOCK DIAGRAM.....	9
3.2	LCD ELECTRONICS SPECIFICATION.....	9
3.3	LVDS DATA FORMAT .....	11
3.4	INPUT SIGNAL TIMING SPECIFICATIONS .....	12
3.5	LED BACKLIGHT CONVERTER SPECIFICATIONS .....	13
3.6	LED LIGHT BAR UNIT .....	15
3.7	DISPLAY MODE CONTROL.....	16
3.8	TOTAL POWER CONSUMPTION .....	17
3.9	PIN ASSIGNMENT .....	18
3.10	POWER ON/OFF SEQUENCE.....	20
3.11	COLOR DATA INPUT ASSIGNMENT .....	22
<b>4</b>	<b>OPTICAL CHARACTERISTICS .....</b>	<b>23</b>
4.1	TEST CONDITIONS.....	23
4.2	OPTICAL SPECIFICATIONS.....	23
<b>5</b>	<b>RELIABILITY TEST ITEMS .....</b>	<b>27</b>
<b>6</b>	<b>PRECAUTIONS.....</b>	<b>28</b>
6.1	SYSTEM MATCHING PRECAUTIONS.....	28



6.2	HANDLING PRECAUTIONS .....	28
6.3	STORAGE PRECAUTIONS .....	28
6.4	OPERATION PRECAUTIONS .....	28
6.5	OTHER PRECAUTIONS .....	28
<b>7</b>	<b>PACKING .....</b>	<b>29</b>
7.1	CARTON .....	29
7.2	PALLET .....	30
<b>8</b>	<b>DEFINITION OF LABELS.....</b>	<b>31</b>
8.1	MODULE LABEL .....	31
8.2	CARTON LABEL .....	32
<b>APPENDIX</b>	<b>EDID DATA STRUCTURE.....</b>	<b>33</b>



**REVISION HISTORY**

Version	Date	Page (New)	Section	Description
Ver 1.0	Apr. 20, 2009	All	All	Initial customer release
Ver 1.1	June 16 2009			Modifications based on measured performance of first working samples
Ver 1.2	July 21, 2009			Updated electrical specifications
Ver 1.3	July 28, 2009		8	Optical specifications revised.
Ver 1.4	Sept 4, 2009		3, 8	Electrical and optical specifications revised.
Ver 1.5	Jan 22, 2010		8	Optical specifications revised
Ver 1.6	Jan 27, 2010		3.1, 3.3, 8	Power and optical characteristics updated
Ver 1.7	Mar 10, 2010		3.1, 3.3, 8	Power and optical characteristics updated
Ver 1.7.1	Mar 16, 2010	29	8	Updated white point tolerance
Ver 1.8	Apr 18, 2010		8	Added brightness in office lighting and sunlight
Ver 1.8.1	Apr 19, 2010		8	Corrected typo in table 8.2
Ver 1.9	June 4, 2010	29	3,1, 3.3, 8	Power and optical characteristics updated
Ver 2.0	July 13, 2010		3, 6, 8	Updated power, optics data, and reflectivity measurement method
Ver 2.1	July 21, 2010			Reorganized sections
Ver 2.2	Sept 19, 2011	7	2.1	Updated operating and storage temperature range

**Note: All specifications are subject to change without notice.**



## 1 GENERAL DESCRIPTION

### 1.1 OVERVIEW

PQ 3Qi-01 is a 10.1" TFT Liquid Crystal Display module with LED backlight unit and 40 pin LVDS interface. This module supports 1024 x 600 Wide-SVGA (WSVGA) mode and can display 262,144 colors. This module also supports two low power modes: a transmissive mode with lower color and a reflective black and white (64 grayscales) mode. The converter module for backlight is built in.

### 1.2 FEATURES

- WSVGA (1024 x 600 pixels) resolution
- 3.3V LVDS (Low Voltage Differential Signaling) interface with 1 pixel/clock
- Built in LED Converter
- Transmissive, transreflective, and reflective display modes

### 1.3 APPLICATIONS

- Mobile notebook or netbook
- Multimedia tablet

### 1.4 GENERAL SPECIFICATIONS

Item	Specification	Unit	Note
Active Area	222.72 (H) x 125.28 (V) (10.06" diagonal)	mm	(1)
Bezel Opening Area	226.34 (H) x 128.1 (V)	mm	
Driver Element	a-Si TFT active matrix	-	-
Pixel Number	1024 x R.G.B. x 600	pixel	(2)
Pixel Pitch	0.2175 (H) x 0.2088 (V)	mm	-
Pixel Arrangement	RGB vertical stripe + 3 reflective subpixels	-	-
Display Colors	262,144	color	-
Display Operating Modes	Transmissive, transreflective, reflective. Normally black	-	-
Surface Treatment	Hard coating (3H), Anti-Glare	-	-

### 1.5 MECHANICAL SPECIFICATIONS

Item	Min.	Typ.	Max.	Unit	Note	
Module Size	Horizontal(H)	234.5	235.0	235.5	mm	(1)
	Vertical(V)	142.5	143.0	143.5	mm	
	Thickness(T)	-	4.9	5.2	mm	
Weight	-	185	195	g		

Note (1) Please refer to the attached drawings for more information of front and back outline dimensions.

Note (2) Each pixel is composed of 3 transmissive subpixels (RGB) and 3 reflective subpixels (grayscale).

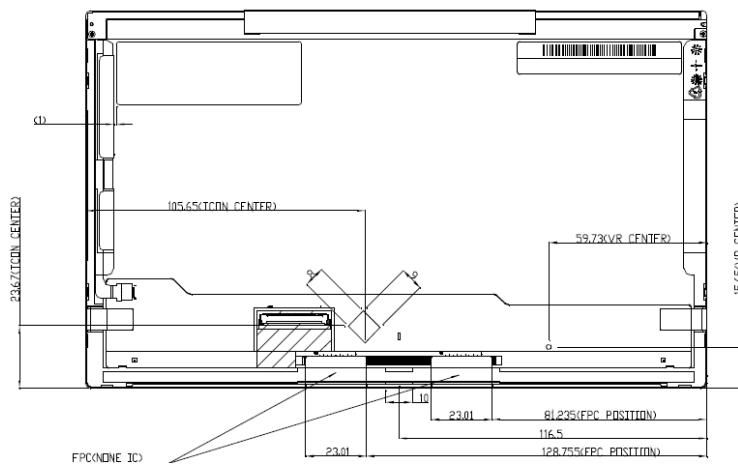
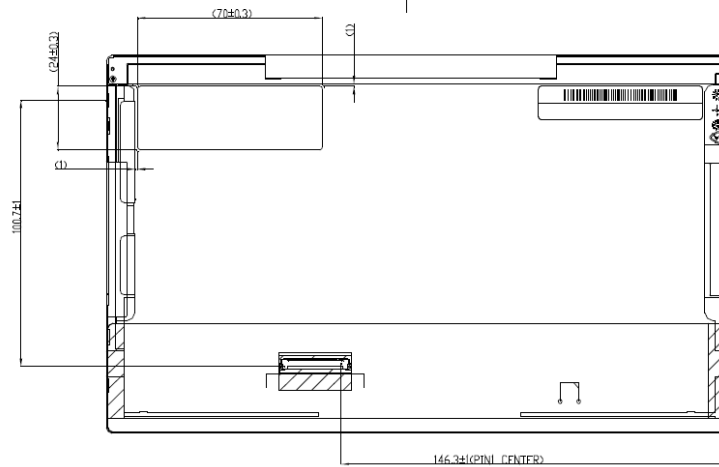
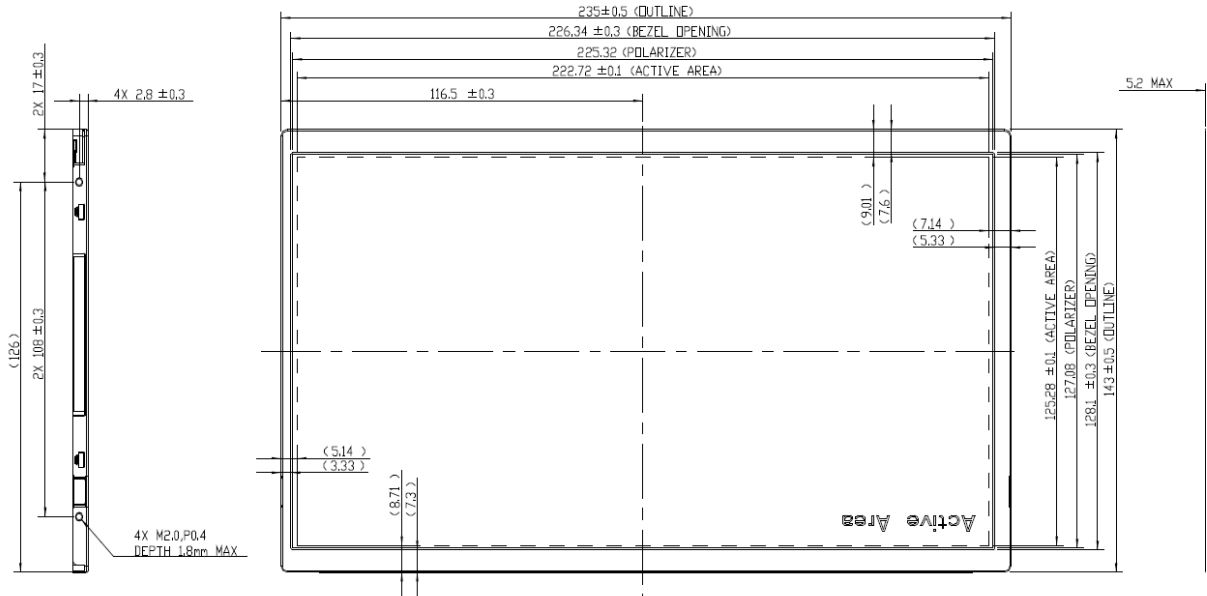



## 2 ABSOLUTE MAXIMUM RATINGS

### 2.1 ABSOLUTE MAXIMUMS, ENVIRONMENTAL

Item	Symbol	Value		Unit	Note
		Min.	Max.		
Storage Temperature	T <sub>ST</sub>	-20	+70	°C	(1)
Operating Ambient Temperature	T <sub>OP</sub>	0	+50	°C	(1), (2)
Extended Operational Temperature	T <sub>EOpp</sub>	-20	+70	°C	(1d)

Note (1) Temperature and relative humidity range is shown in the figure below:

- (a) 90 %RH Max. (Ta <= 40 °C)
- (b) Wet-bulb temperature should be 39 °C Max. (Ta > 40 °C)
- (c) No condensation
- (d) Panel will function but may not meet performance specifications in the extended operational temperature range.

Note (2) The temperature of panel surface area should be 0 °C min. and 50 °C max.

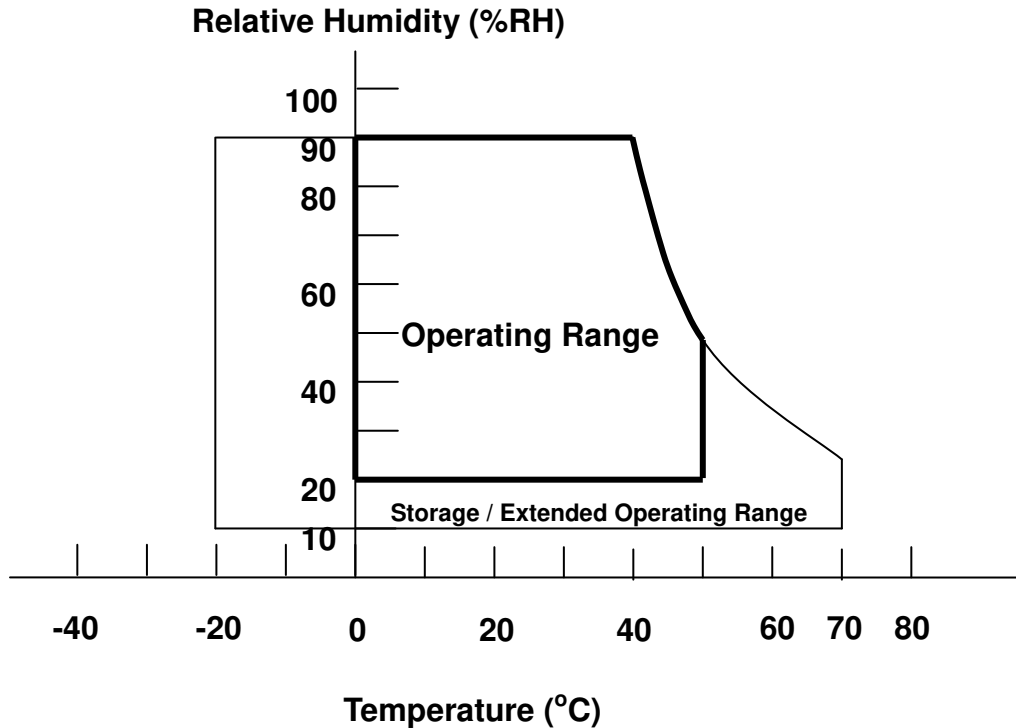

## 2.2 ABSOLUTE MAXIMUMS, ELECTRICAL

Permanent damage to the device may occur if maximum values are exceeded. Operation should be restricted to the conditions described under Normal Operating Conditions.

### 2.2.1 TFT LCD MODULE

Item	Symbol	Value		Unit	Note
		Min.	Max.		
Power Supply Voltage	$V_{CC}$	-0.3	+4.0	V	
Logic Input Voltage	$V_{IN}$	-0.3	$V_{CC}+0.3$	V	

### 2.2.2 BACKLIGHT CONVERTER INPUT

Item	Symbol	Value		Unit	Note
		Min.	Max.		
Converter Input Voltage	LED $V_{CC}$	-0.3	+25.0	V	
Converter Control Signal	LED PWM	-0.3	+5.5	V	
Converter Control Signal	LED EN	-0.3	+5.5	V	

### 2.2.3 LED LIGHT BAR UNIT

Item	Value		Unit	Note
	Min	Max.		
LED Light Bar Power Supply Voltage	-45	30.6	$V_{DC}$	(1)
LED Light Bar Power Supply Current	0	75	$mA_{DC}$	

Note (1) Specified values are for the LED light bar (Refer to Section 3.5 for further information).



### 3 ELECTRICAL CHARACTERISTICS

#### 3.1 FUNCTIONAL BLOCK DIAGRAM

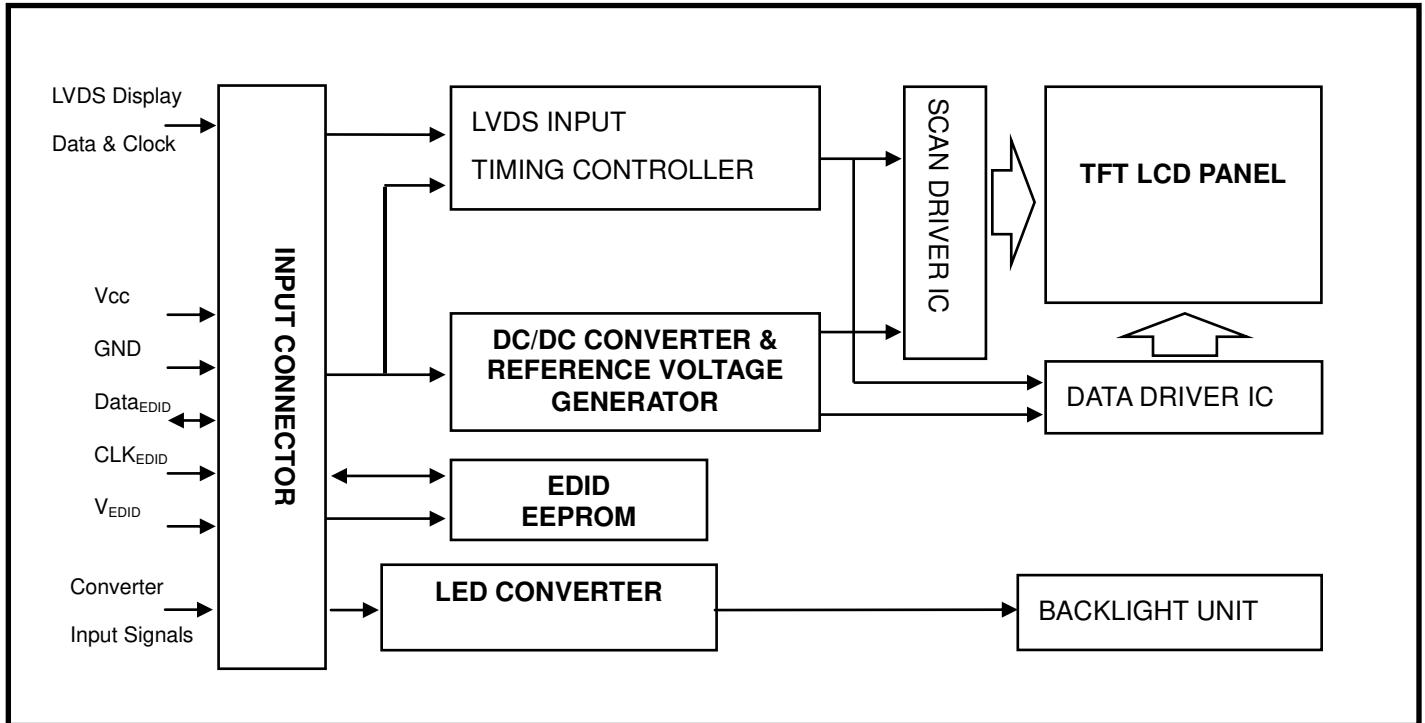

#### 3.2 LCD ELECTRONICS SPECIFICATION

Parameter	Symbol	Value			Unit	Note
		Min.	Typ.	Max.		
Power Supply Voltage	V <sub>CC</sub>	3.0	3.3	3.6	V	-
Ripple Voltage	V <sub>RP</sub>	-	50		mV	-
Rush Current	I <sub>RUSH</sub>	-	-	1.5	A	(2)
Initial Stage Current	I <sub>IS</sub>	-	-	1.0	A	(2)
Power Supply Current	White	179	203	228	mA	(3)a
	Black	135	153	171	mA	(3)b
LVDS Differential Input High Threshold	V <sub>TH(LVDS)</sub>	-	-	+100	mV	(4), V <sub>CM</sub> =1.2V
LVDS Differential Input Low Threshold	V <sub>TL(LVDS)</sub>	-100	-	-	mV	(4) V <sub>CM</sub> =1.2V
LVDS Common Mode Voltage	V <sub>CM</sub>	1.125	-	1.375	V	(4)
LVDS Differential Input Voltage	V <sub>ID</sub>	100	-	600	mV	(4)
Terminating Resistor	R <sub>T</sub>	-	100	-	Ohm	-

Note (1) The ambient temperature is Ta = 25 ± 2 °C.

Note (2) I<sub>RUSH</sub>: the maximum current when V<sub>CC</sub> is rising

I<sub>IS</sub>: the maximum current of the first 100ms after power-on

Measurement Conditions: Shown in the following figure. Test pattern: black.

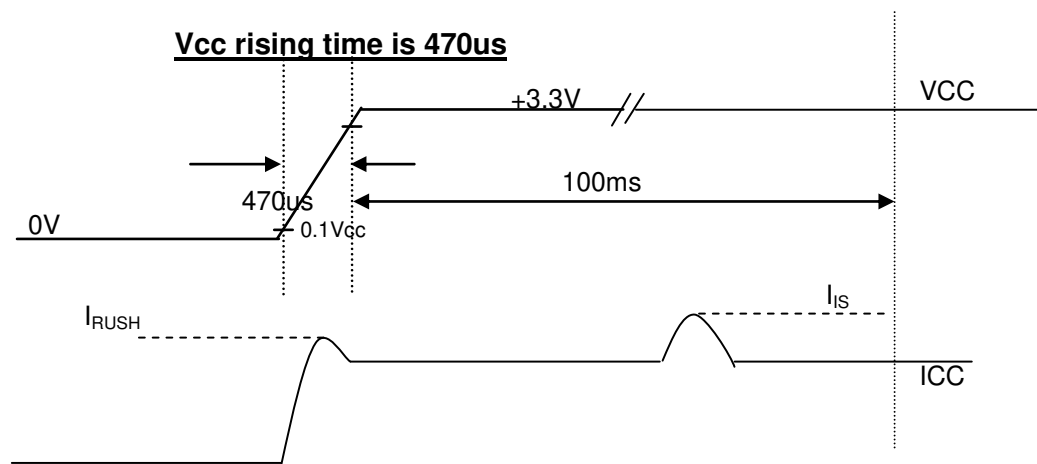
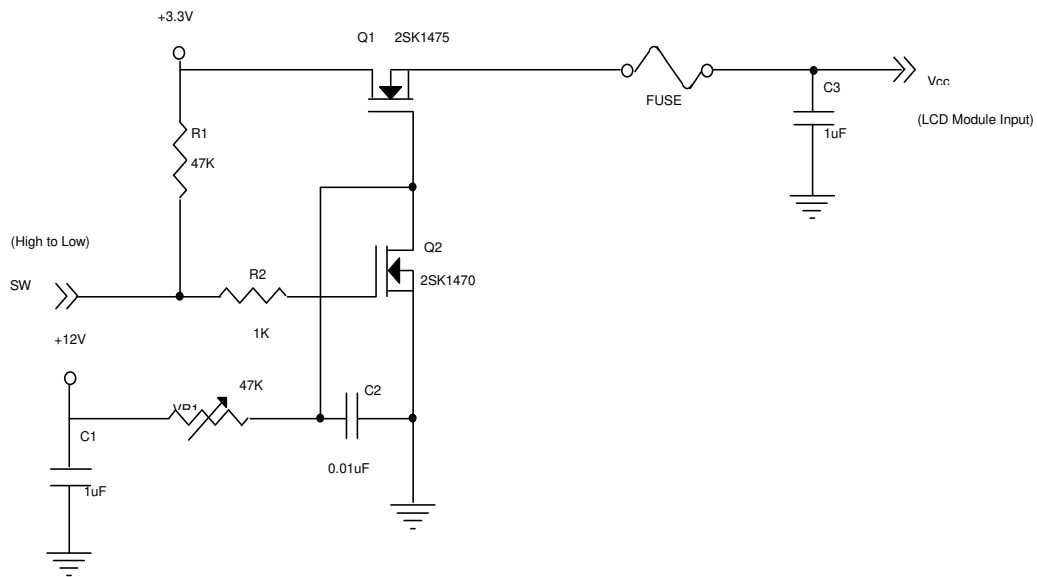

Note (3) The specified power supply current is under the conditions at  $V_{cc} = 3.3\text{ V}$ ,  $T_a = 25 \pm 2\text{ }^\circ\text{C}$ , DC and  $f_v = 60\text{ Hz}$ , with a power dissipation check pattern (below) displayed.

a. White Pattern

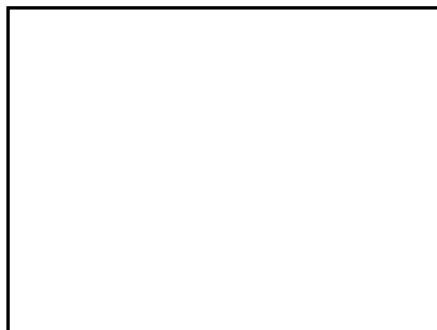

Active Area

b. Black Pattern

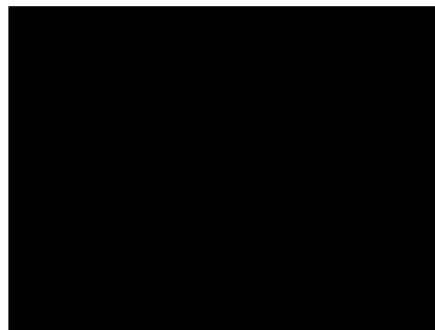

Active Area



Note (4) The parameters of LVDS signals are defined as the following figures.

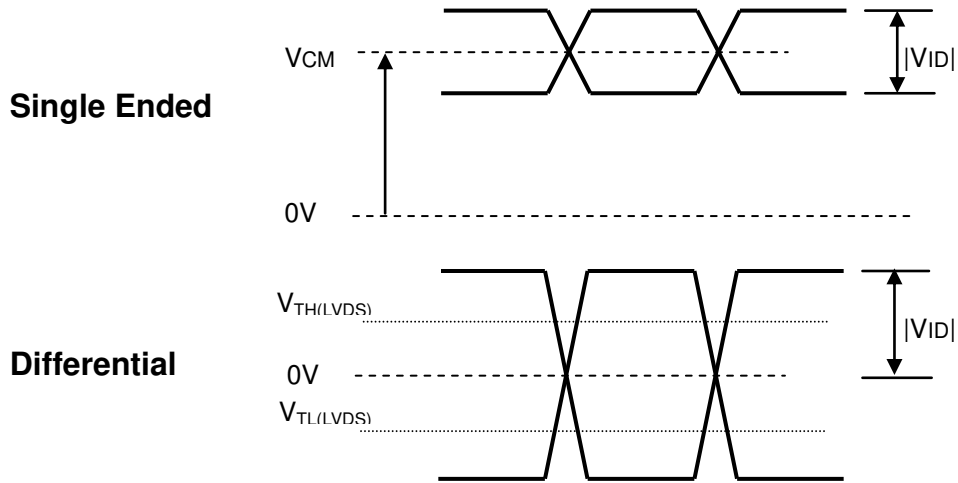

### 3.3 LVDS DATA FORMAT

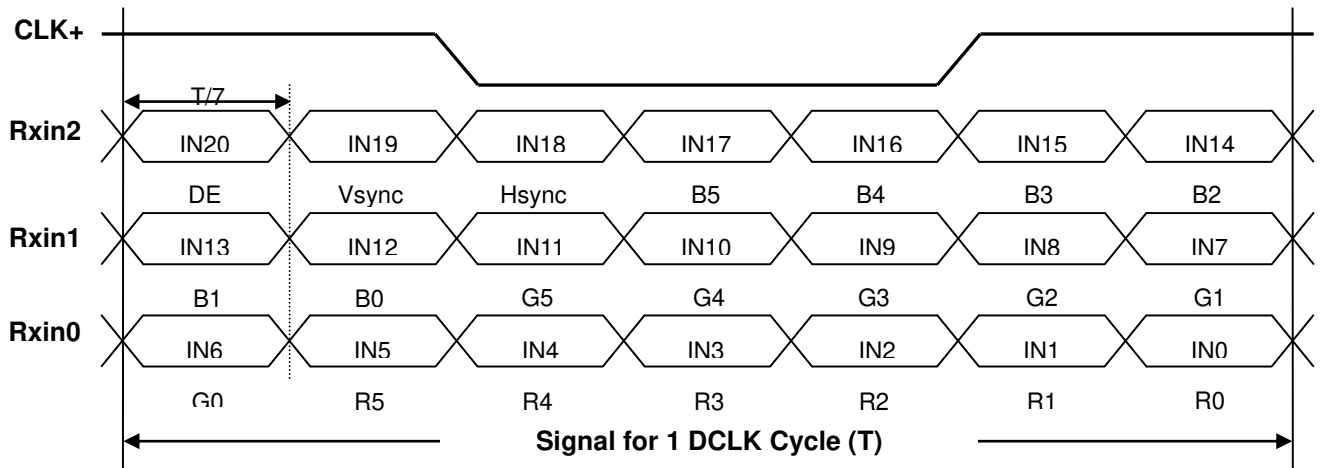



### 3.4 INPUT SIGNAL TIMING SPECIFICATIONS

The input signal timing specifications are shown as the following table and timing diagram.

Signal	Item	Symbol	Min.	Typ.	Max.	Unit	Note
DCLK	Frequency	1/Tc	21.74	43.97	46.15	MHz	-
DE	Vertical Total Time	TV	602	619	624	TH	-
	Vertical Active Display Period	TVD	600	600	600	TH	-
	Vertical Active Blanking Period	TVB	TV-TVD	19	TV-TVD	TH	-
	Horizontal Total Time	TH	1104	1184	1240	Tc	-
	Horizontal Active Display Period	THD	1024	1024	1024	Tc	-
	Horizontal Active Blanking Period	THB	TH-THD	160	TH-THD	Tc	-

Note (1) Because this module is operated in DE only mode, Hsync and Vsync are ignored.

#### INPUT SIGNAL TIMING DIAGRAM

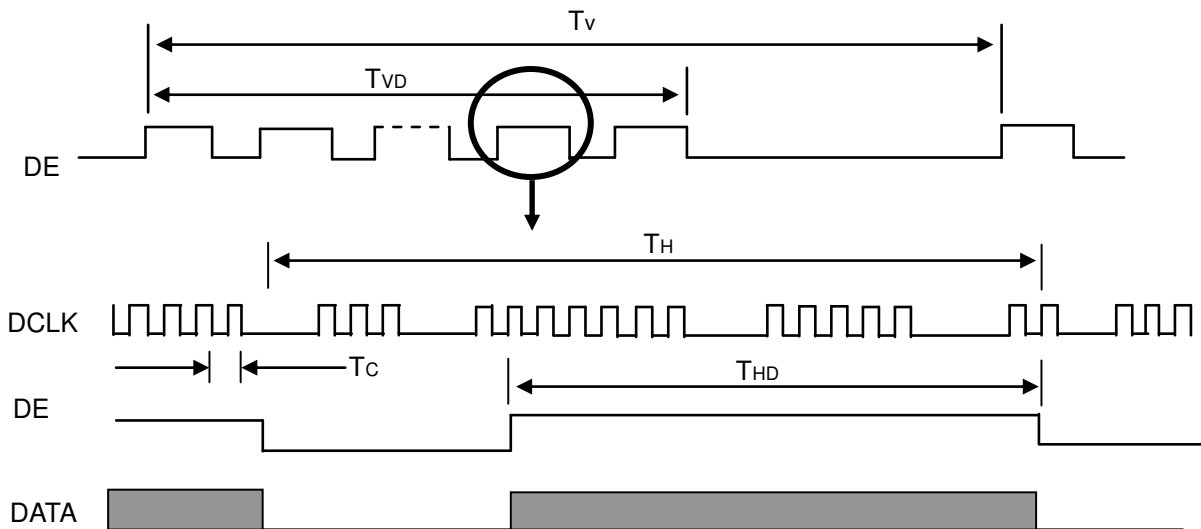

### 3.5 LED BACKLIGHT CONVERTER SPECIFICATIONS

Parameter	Symbol	Value			Unit	Note	
		Min.	Typ.	Max.			
Converter Input power supply voltage	LED_V <sub>CC</sub>	4.5	18.7	21.0	V		
Converter Rush Current	I <sub>LED<sub>RUSH</sub></sub>			1.5	A	(1)	
Converter Initial Stage Current	I <sub>LED<sub>IS</sub></sub>			1.5	A	(1)	
EN Control Level	LED_EN	Backlight on	2.3	-	5.5	V	
		Backlight off	0	-	0.8	V	
PWM Control Level	LED_PWM	PWM High Level	2.3	-	5.5	V	
		PWM Low Level	0	-	0.8	V	
PWM Control Duty Ratio		10	-	100	%	(2)	
PWM Control Ripple Voltage	V <sub>PWM_pp</sub>		-	100	mV		
PWM Control Frequency	f <sub>PWM</sub>	190	-	2000	Hz	(3)	
LED Power Current	I <sub>LED</sub>	LED_V <sub>CC</sub> = Min	388	452	525	mA	(4)
		LED_V <sub>CC</sub> = Typ	91	109	129	mA	(4)
		LED_V <sub>CC</sub> = Max	83	97	113	mA	(4)

Note (1) I<sub>LED<sub>RUSH</sub></sub>: the maximum current when LED\_V<sub>CC</sub> is rising,

I<sub>LED<sub>IS</sub></sub>: the maximum current of the first 100ms after power-on,

Measurement Conditions: Shown as the following figure. LED\_V<sub>CC</sub> = Typ, T<sub>a</sub> = 25 ± 2 °C, f<sub>PWM</sub> = 200 Hz, Duty=100%.

Note (2) If the PWM control duty ratio is less than 10%, there is some possibility that acoustic noise or backlight flash can be found. And it is also difficult to control the brightness linearity.

#### VLED rising time is 0.5ms

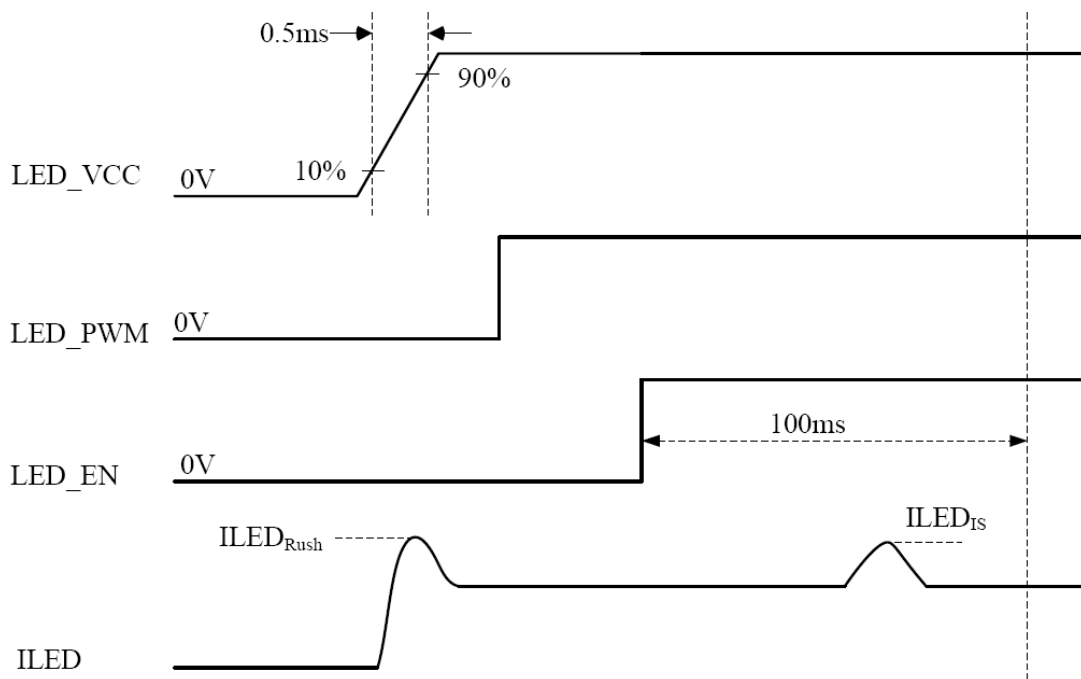

Note (3) If PWM control frequency is applied in the range less than 1 kHz, the “waterfall” phenomenon on the screen may be found. To avoid the issue, it’s a suggestion that PWM control frequency should follow the criterion as below.

PWM control frequency  $f_{PWM}$  should be in the range

$$(N + 0.33) * f \leq f_{PWM} \leq (N + 0.66) * f$$

$N$  : Integer ( $N \geq 3$ )

$f$  : Frame rate

Note (4) The specified LED power supply current is under the conditions at “LED\_VCC = Min., Typ., Max.”,  $T_a = 25 \pm 2$  °C,  $f_{PWM} = 200$  Hz, Duty=100%.



3.6 LED LIGHT BAR UNIT

Parameter	Symbol	Value			Unit	Note
		Min.	Typ.	Max.		
LED Light Bar Power Supply Voltage	V <sub>o</sub>	27	28.8	30.6	V	(1)(2)
LED Light Bar Power Supply Current	I <sub>o</sub>	57	60	63	mA	Duty 100%
Power Consumption (Transmissive Mode)	P <sub>OTM</sub>	1.53	1.73	1.93	W	(1)(3) @I <sub>o</sub> =60mA, Duty 100%
Power Consumption (Transflective Mode)	P <sub>OTF</sub>	0.61	0.69	0.78	W	(1)(3) @I <sub>o</sub> =60mA, Duty 40%
		0.15	0.17	0.2	W	(1)(3) @I <sub>o</sub> =60 mA Duty 10%
Power Consumption (Reflective Mode)	P <sub>ORF</sub>	-	0	0.002	W	(1)
LED Life Time	L <sub>BL</sub>	15000	-	-	Hrs	(4)

Note (1) In transmissive mode, power is given for typical current over the specified voltage range at 100% duty cycle. Dimming the backlight (reducing duty cycle) will reduce power in transmissive mode. In transflective mode, duty cycle is typically lower than Transmissive mode. Lower or higher PWM duty cycle will result in lower or higher power consumption, respectively. In transflective mode, brightness depends on backlight power and ambient light. In reflective mode, the backlight is turned off. Light bar power consumption is zero. For all measurements, T<sub>a</sub> = 25 ± 2 °C

Note (2) LED current is measured by utilizing a high frequency current meter as shown below:

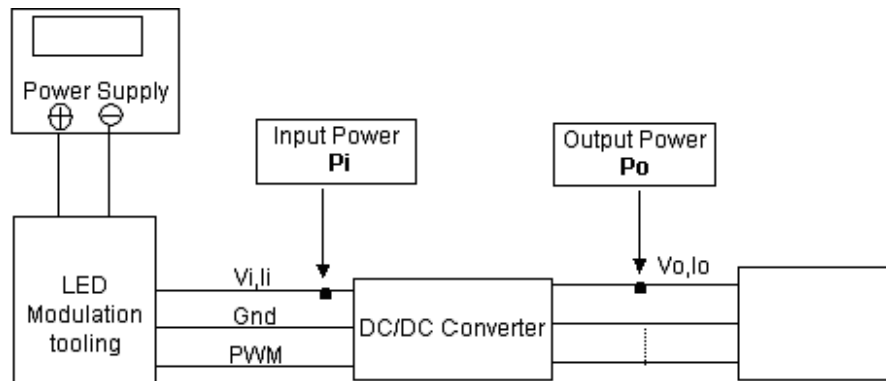

Note (3) P<sub>o</sub> = I<sub>o</sub> × V<sub>o</sub>

Note (4) The lifetime of LED is defined as the time when it continues to operate under the conditions at T<sub>a</sub> = 25 ± 2 °C and I = 17 mA (Per EA) until the brightness becomes ≤ 50% of its original value.



### 3.7 DISPLAY MODE CONTROL

The display panel supports 3 modes: purely reflective, purely transmissive, and transfective. The mode is determined by the ambient light intensity and backlight intensity. The following truth table shows how different modes are selected.

Condition		Description	
Ambient Light	Backlight	Mode	Notes
Non-dark	Off	Reflective	Backlight off, reflective subpixels active, grayscale image, minimum power mode.
Dark	On	Transmissive	Conventional display mode. Backlight on, reflective subpixels black due to absence of ambient light, saturated colors.
Non-dark	On	Transfective	Backlight on, reflective subpixels reflecting ambient light, colors desaturated, power reduced if backlight dimmed.

Please refer to Pixel Qi Mode Control Application Note for more information about mode switching.





### 3.8 TOTAL POWER CONSUMPTION

Mode	Preliminary Value			Unit	Note
	Min.	Typ.	Max.		
Transmissive (Full Color Saturation)	2.24	2.63	3.09	W	(1) 60 fps with ANSI checkerboard pattern, BLU duty 100%
Transmissive (Full Color Saturation)	2.12	2.47	2.87	W	(1) 30 fps with ANSI checkerboard pattern, BLU duty 100%
Transflective (Low Color)	1.15	1.32	1.52	W	(1) 60 fps with ANSI checkerboard pattern, BLU duty 40%
	0.74	0.82	0.90	W	(1) 60 fps with ANSI checkerboard pattern, BLU duty 10%
	0.59	0.66	0.72	W	(1) 30 fps with ANSI checkerboard pattern, BLU duty 10%
Reflective (Black and white with 64 gray shades)	0.52	0.59	0.64	W	(1) 60 fps
Reflective (Black and white with 64 gray shades)	0.39	0.43	0.48	W	(1) 30 fps

Note (1) Total power consumption includes LCD, TCON, drivers, TFT, LED converter, DC-DC converters, and backlight unit. Power is given for ANSI checkerboard pattern and typical backlight unit voltage and current values with 100% duty cycle in transmissive mode and over a range of backlight duty cycle values in transflective mode. Note that purely transmissive mode is only possible under zero lux ambient light conditions. In transflective mode, duty cycle is typically lower than transmissive mode, but the maximum value is the same. In reflective mode, the backlight is turned off; light bar power consumption is zero.



### 3.9 PIN ASSIGNMENT

Pin	Symbol	Description	Polarity	Remark
1	NC	No Connection (Reserve)		
2	VCC	Power Supply		
3	VCC	Power Supply		
4	VEDID	DDC power		May be connected to VCC
5	NC	No Connection (Reserve for test)		
6	CLKEDID	DDC clock		
7	DATAEDID	DDC data		
8	Rxin0-	LVDS differential data input	Negative	R0-R5, G0
9	Rxin0+	LVDS differential data input	Positive	
10	VSS	Ground		
11	Rxin1-	LVDS differential data input	Negative	G1~G5, B0, B1
12	Rxin1+	LVDS differential data input	Positive	
13	VSS	Ground		
14	Rxin2-	LVDS Differential Data Input	Negative	B2-B5,HS,VS, DE
15	Rxin2+	LVDS Differential Data Input	Positive	
16	VSS	Ground		
17	RxCLK-	LVDS differential clock input		
18	RxCLK+	LVDS differential clock input		
19	VSS	Ground		
20	NC	No Connection (Reserve)		
21	NC	No Connection (Reserve)		
22	VSS	Ground		
23	NC	No Connection (Reserve)		
24	NC	No Connection (Reserve)		
25	VSS	Ground		
26	NC	No Connection (Reserve)		
27	NC	No Connection (Reserve)		
28	VSS	Ground		
29	NC	No Connection (Reserve)		
30	NC	No Connection (Reserve)		
31	VSS	LED Ground		
32	VSS	LED Ground		
33	VSS	LED Ground		
34	NC	No Connection (Reserve)		
35	LED_PWM	LED BLU Brightness Control		
36	LED_EN	LED Converter Enable		
37	NC	No Connection (Reserve)		
38	LED_V <sub>CC</sub>	LED Converter Input Power		Also referred to as VLED
39	LED_V <sub>CC</sub>	LED Converter Input Power		
40	LED_V <sub>CC</sub>	LED Converter Input Power		

Note (1) Connector Part No.: IPEX-20455-040E-12 or equivalent

Note (2) User's connector Part No: IPEX-20453-040T-01 or equivalent

Note (3) The first pixel is odd as shown in the following figure.

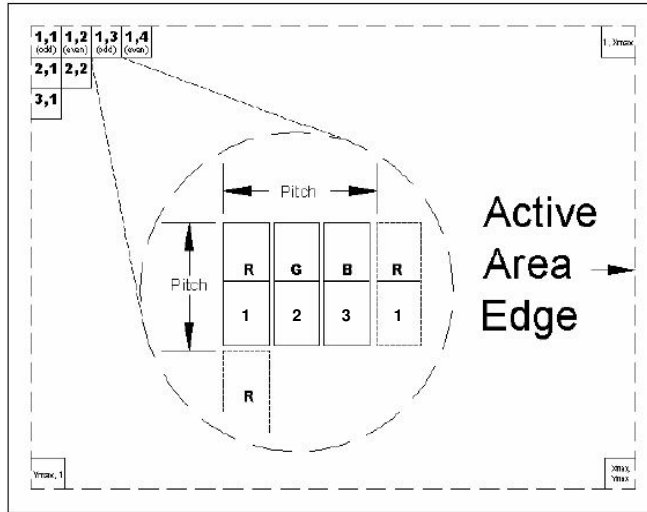



### 3.10 POWER ON/OFF SEQUENCE

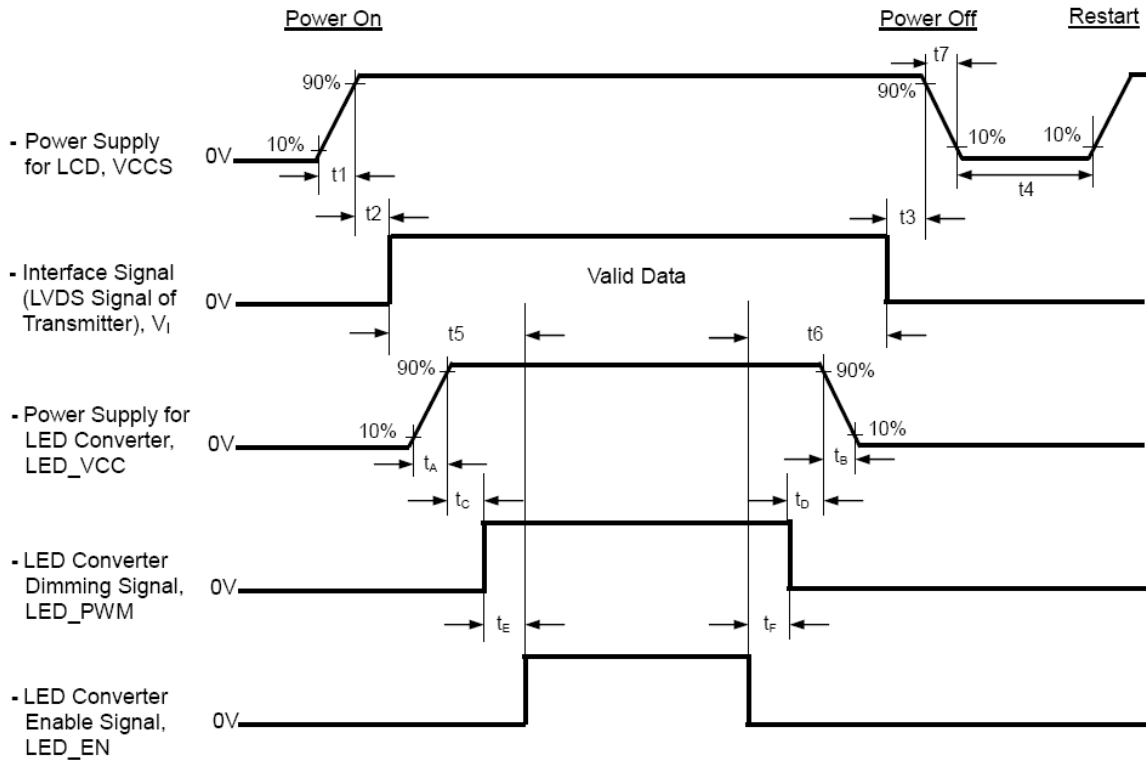

#### Timing Specifications:

- $0.5 \leq t_1 \leq 10 \text{ ms}$
- $0 \leq t_2 \leq 50 \text{ ms}$
- $0 \leq t_3 \leq 50 \text{ ms}$
- $t_4 \geq 500 \text{ ms}$
- $t_5 \geq 200 \text{ ms}$
- $t_6 \geq 200 \text{ ms}$
- $0.5 \leq t_7 \leq 10 \text{ ms}$
- $0.5 \leq t_A \leq 10 \text{ ms}$
- $0 < t_B \leq 10 \text{ ms}$
- $t_C \geq 10 \text{ ms}$
- $t_D \geq 10 \text{ ms}$
- $t_E \geq 10 \text{ ms}$
- $t_F \geq 10 \text{ ms}$

Note (1) Please follow the power on/off sequence described above. Otherwise, the LCD module might be damaged.



Note (2) Please avoid floating state of interface signal during invalid periods. When the interface signal is invalid, be sure to pull down the LCD power supply Vcc to 0 V.

Note (3) The backlight inverter power must be turned on after the power supply for the logic and the interface signals is valid. The backlight inverter power must be turned off before the power supply for the logic and the interface signals is invalid.

Note (4) Sometimes some slight image shows when LCD is turned off (even if the backlight is already off). To avoid this phenomenon, the Vcc falling time should follow  $50\mu\text{s} \leq t_f \leq 10\text{ ms}$ .



### 3.11 COLOR DATA INPUT ASSIGNMENT

The brightness of each primary color (red, green and blue) is based on the 6-bit gray scale data input for the color. The higher the binary input the brighter the color. The table below provides the assignment of color versus data input.

Color		Data Signal																	
		Red						Green						Blue					
		R5	R4	R3	R2	R1	R0	G5	G4	G3	G2	G1	G0	B5	B4	B3	B2	B1	B0
Basic Colors	Black	0	0	0	0	0	0	0	0	0	0	0	0	0	0	0	0	0	0
	Red	1	1	1	1	1	1	0	0	0	0	0	0	0	0	0	0	0	0
	Green	0	0	0	0	0	0	1	1	1	1	1	1	0	0	0	0	0	0
	Blue	0	0	0	0	0	0	0	0	0	0	0	0	1	1	1	1	1	1
	Cyan	0	0	0	0	0	0	1	1	1	1	1	1	1	1	1	1	1	1
	Magenta	1	1	1	1	1	1	0	0	0	0	0	0	1	1	1	1	1	1
	Yellow	1	1	1	1	1	1	1	1	1	1	1	1	0	0	0	0	0	0
	White	1	1	1	1	1	1	1	1	1	1	1	1	1	1	1	1	1	1
Gray Scale Of Red	Red(0)/Dark	0	0	0	0	0	0	0	0	0	0	0	0	0	0	0	0	0	0
	Red(1)	0	0	0	0	0	1	0	0	0	0	0	0	0	0	0	0	0	0
	Red(2)	0	0	0	0	1	0	0	0	0	0	0	0	0	0	0	0	0	0
	:	:	:	:	:	:	:	:	:	:	:	:	:	:	:	:	:	:	:
	:	:	:	:	:	:	:	:	:	:	:	:	:	:	:	:	:	:	:
	:	:	:	:	:	:	:	:	:	:	:	:	:	:	:	:	:	:	:
	Red(61)	1	1	1	1	0	1	0	0	0	0	0	0	0	0	0	0	0	0
	Red(62)	1	1	1	1	1	0	0	0	0	0	0	0	0	0	0	0	0	0
Red(63)	1	1	1	1	1	1	0	0	0	0	0	0	0	0	0	0	0	0	
Gray Scale Of Green	Green(0)/Dark	0	0	0	0	0	0	0	0	0	0	0	0	0	0	0	0	0	0
	Green(1)	0	0	0	0	0	0	0	0	0	0	0	1	0	0	0	0	0	0
	Green(2)	0	0	0	0	0	0	0	0	0	0	1	0	0	0	0	0	0	0
	:	:	:	:	:	:	:	:	:	:	:	:	:	:	:	:	:	:	:
	:	:	:	:	:	:	:	:	:	:	:	:	:	:	:	:	:	:	:
	:	:	:	:	:	:	:	:	:	:	:	:	:	:	:	:	:	:	:
	Green(61)	0	0	0	0	0	0	1	1	1	1	0	1	0	0	0	0	0	0
	Green(62)	0	0	0	0	0	0	1	1	1	1	1	0	0	0	0	0	0	0
Green(63)	0	0	0	0	0	0	1	1	1	1	1	1	0	0	0	0	0	0	
Gray Scale Of Blue	Blue(0)/Dark	0	0	0	0	0	0	0	0	0	0	0	0	0	0	0	0	0	0
	Blue(1)	0	0	0	0	0	0	0	0	0	0	0	0	0	0	0	0	0	1
	Blue(2)	0	0	0	0	0	0	0	0	0	0	0	0	0	0	0	0	1	0
	:	:	:	:	:	:	:	:	:	:	:	:	:	:	:	:	:	:	:
	:	:	:	:	:	:	:	:	:	:	:	:	:	:	:	:	:	:	:
	:	:	:	:	:	:	:	:	:	:	:	:	:	:	:	:	:	:	:
	Blue(61)	0	0	0	0	0	0	0	0	0	0	0	0	1	1	1	1	0	1
	Blue(62)	0	0	0	0	0	0	0	0	0	0	0	0	1	1	1	1	1	0
Blue(63)	0	0	0	0	0	0	0	0	0	0	0	0	1	1	1	1	1	1	

Note (1) 0: Low Level Voltage, 1: High Level Voltage



## 4 OPTICAL CHARACTERISTICS

### 4.1 TEST CONDITIONS

Item	Symbol	Value	Unit
Ambient Temperature	Ta	25±2	°C
Ambient Humidity	Ha	50±10	%RH
Supply Voltage	V <sub>CC</sub>	3.3	V
Input Signal	According to typical values in "ELECTRICAL CHARACTERISTICS"		
LED Light Bar Input Current	I <sub>L</sub>	60	mA

### 4.2 OPTICAL SPECIFICATIONS

Item	Symbol	Condition	Min.	Typ.	Max.	Unit	Note
Contrast Ratio Transmissive	CR <sub>T</sub>	$\theta_x=0^\circ, \theta_y=0^\circ$ Viewing Normal Angle	50	100	-	-	(1), (2), (5), (6)
Contrast Ratio Reflective	CR <sub>R</sub>		3.5	5	-	-	(1), (2), (6), (7)
Response Time	T <sub>R</sub>		-	6.5	11.5	ms	(3)
	T <sub>F</sub>		-	13.5	18.5	ms	
Panel Reflectivity			23	27	-	%	(7)
Luminance of White	L	Dark room	110	160	-	cd/m <sup>2</sup>	(1), (4), (5), (6)
	L <sub>office</sub>	600 lux ambient		233			
	L <sub>sun</sub>	10000+ lux ambient	1000				
Color Gamut				38	45	% NTSC	
Color Chromaticity, Transmissive	Red	R <sub>x</sub>	TYP. -0.05	0.552	TYP. +0.05		(1)
		R <sub>y</sub>		0.344			
	Green	G <sub>x</sub>		0.327			
		G <sub>y</sub>		0.558			
	Blue	B <sub>x</sub>		0.163			
		B <sub>y</sub>		0.163			
	White	W <sub>x</sub>		0.313			
		W <sub>y</sub>		0.342			
Color Chromaticity, Reflective @D65	White	W <sub>x</sub>	TYP. -0.05	0.310	TYP. +0.05		
		W <sub>y</sub>		0.350			
Viewing Angle, Transmissive Mode	Horizontal	$\theta_{x+}$	CR $\square$ 10	20	30	Deg.	(1), (2), (5)
		$\theta_{x-}$		20	30		
	Vertical	$\theta_{y+}$		20	30		
		$\theta_{y-}$		20	30		
Viewing Angle, Reflective Mode	Horizontal	$\theta_{x+}$	CR $\square$ 4	30	40	Deg.	(1), (2), (7)
		$\theta_{x-}$		30	40		
	Vertical	$\theta_{y+}$		20	30		
		$\theta_{y-}$		20	30		
White Variation (Transmissive)	5 points	$\delta W_{5p}$	$\theta_x=0^\circ, \theta_y=0^\circ$		1.11	1.33	(1), (5), (6)
	13 points	$\delta W_{13p}$			1.33	1.65	
White Variation (Reflective)	5 points	$\delta W_{r5p}$			1.11	1.33	(1), (6), (7)

Note (1) Definition of Viewing Angle ( $\theta_x, \theta_y$ ):

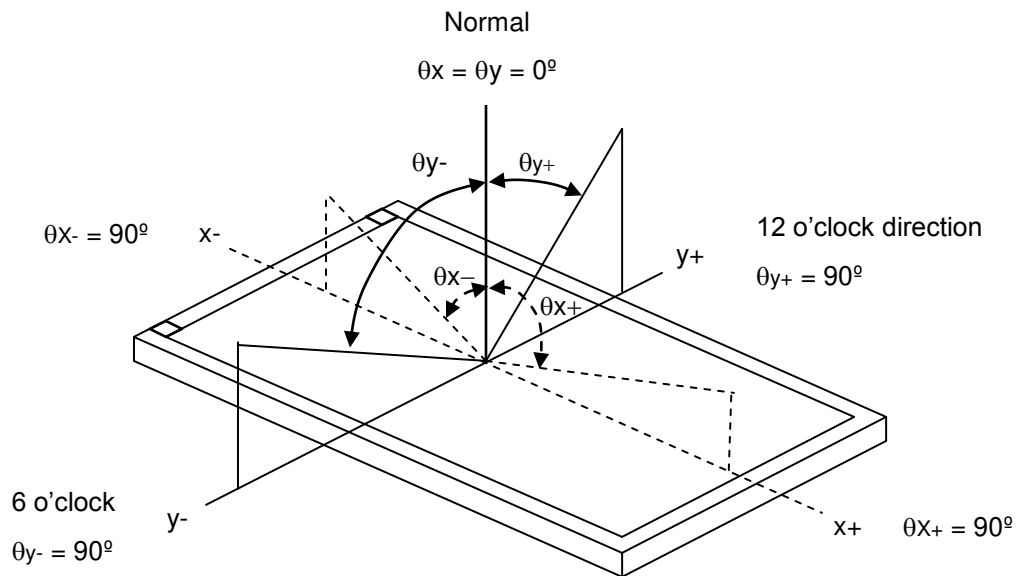

Note (2) Definition of Contrast Ratio (CR):

The contrast ratio can be calculated by the following expression.

$$\text{Contrast Ratio (CR)} = L_{63} / L_0$$

L63: Luminance of gray level 63

L 0: Luminance of gray level 0

$$CR = CR(1)$$

CR (X) is corresponding to the Contrast Ratio of the point X at Figure in Note (6).

Note (3) Definition of Response Time ( $T_R, T_F$ ):

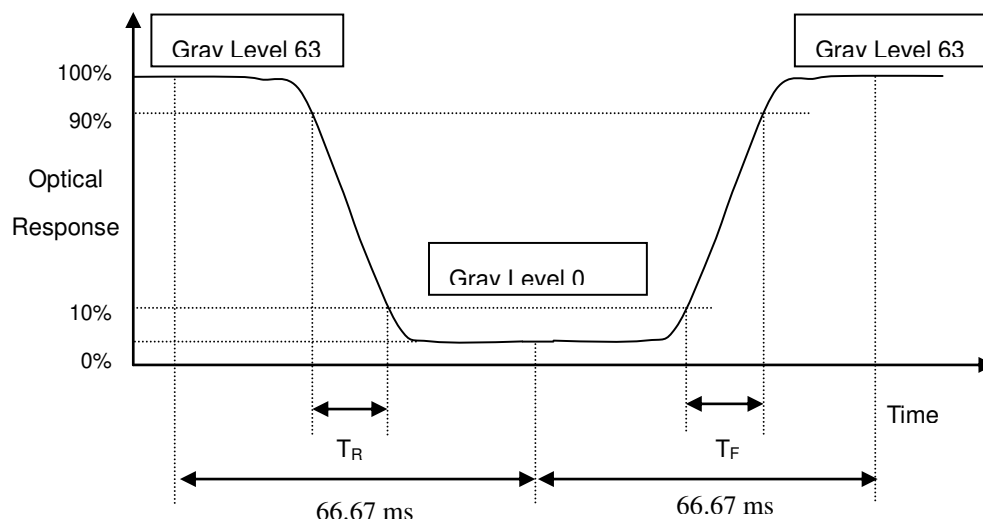



Note (4) Definition of Luminance of White (L):

Measure the luminance of gray level 63 at center point

$$L = L(1)$$

L(x) is corresponding to the luminance of the point X at Figure in Note (6)

Note (5) Measurement Setup:

The LCD module should be stabilized at given temperature for 20 minutes to avoid abrupt temperature change during measuring. In order to stabilize the luminance, the measurement should be executed after lighting backlight for 20 minutes in a windless room.

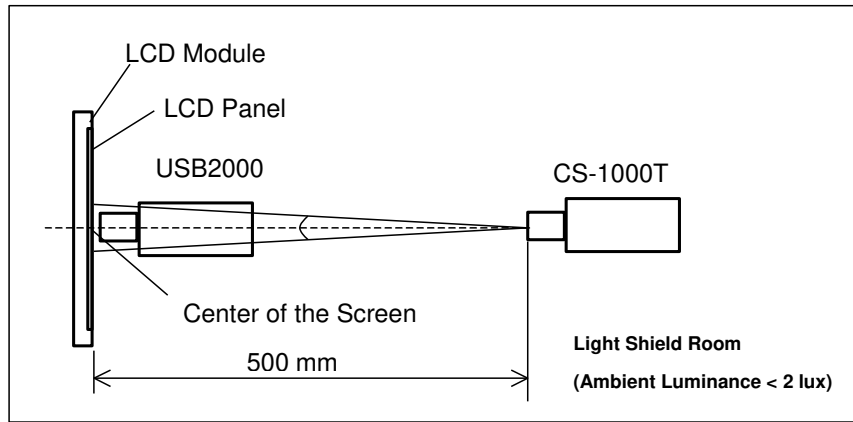

Note (6) Definition of White Variation ( $\delta W$ ):

Measure the luminance of gray level 63 at 5 or 13 points

$$\delta W_{5p} = \text{Maximum } [L(1) \sim L(5)] / \text{Minimum } [L(1) \sim L(5)]$$

$$\delta W_{13p} = \text{Maximum } [L(1) \sim L(13)] / \text{Minimum } [L(1) \sim L(13)]$$

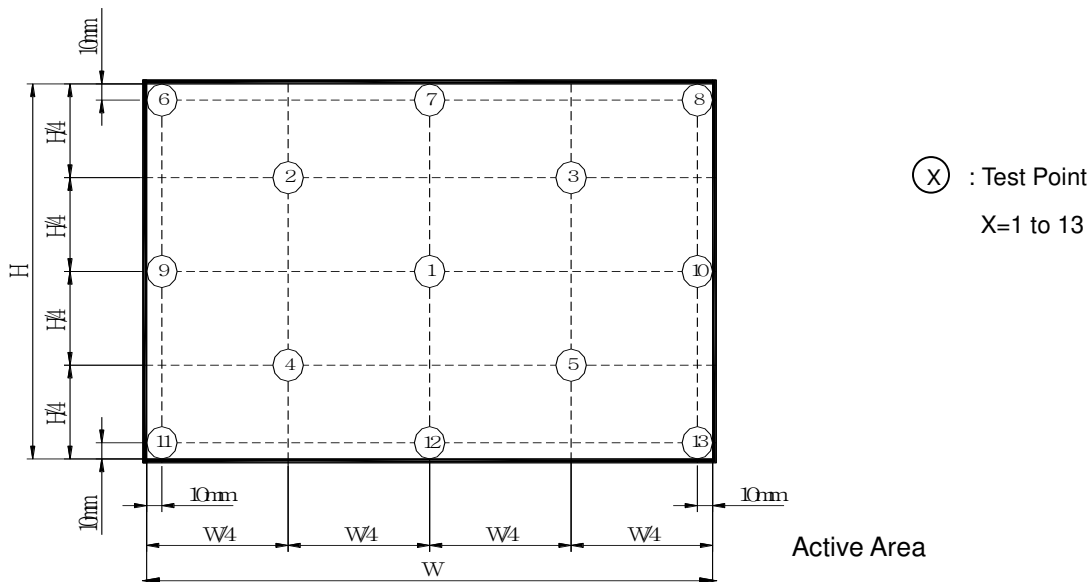

Note (7) Reflective Mode Measurement Setup

The measurement should be executed after stabilizing the panel at a given temperature for 15 minutes in the case of abrupt temperature change. The measurement shall be executed after lighting the integrated diffuse light at rating 15 minutes and turning off the backlight of LCD panel. In order to stabilize the luminance, measurement should be performed in a windless room.

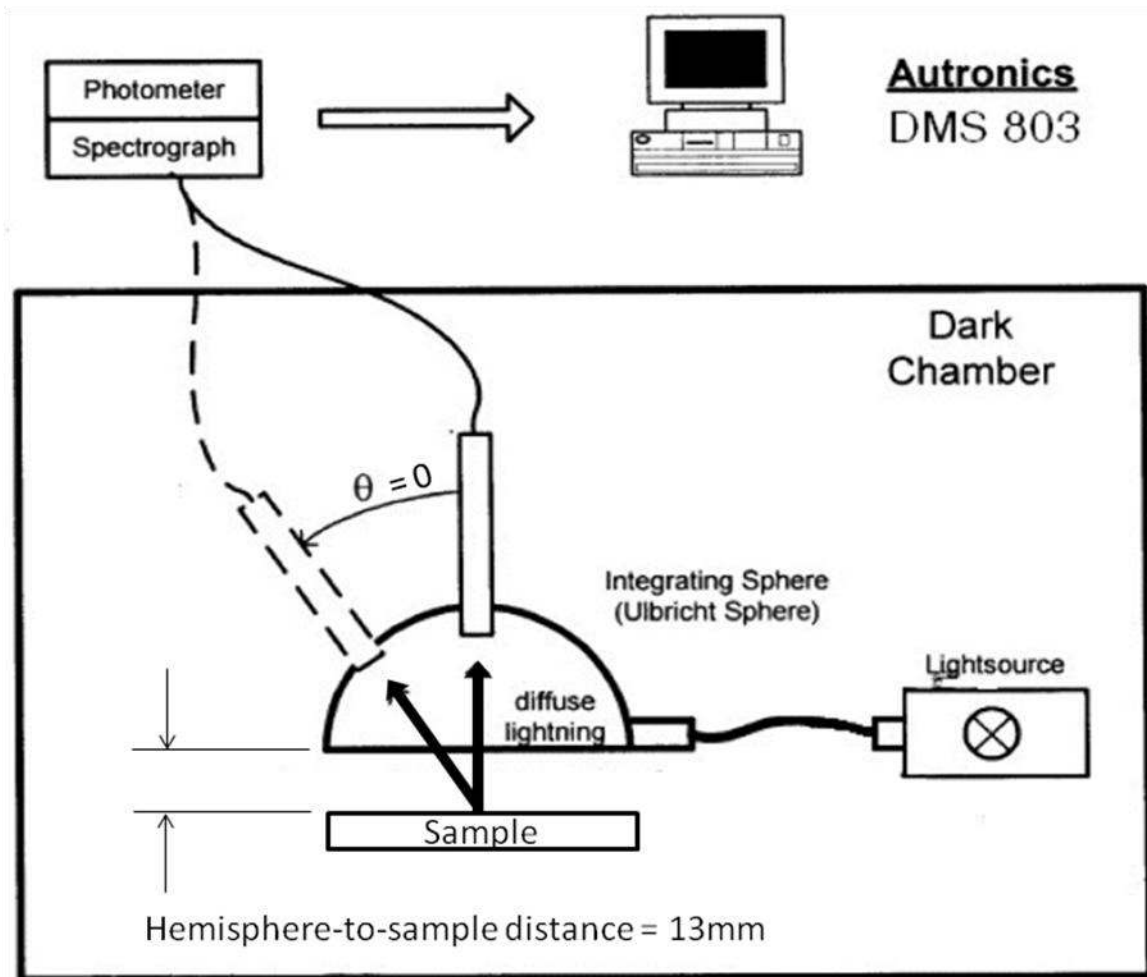



5 RELIABILITY TEST ITEMS

Test Item	Test Condition	Note
High Temperature Storage Test	60 °C, 240 hours	(1), (2)
Low Temperature Storage Test	-20 °C, 240 hours	
Thermal Shock Storage Test	-20 °C, 0.5 hour ↔ 60 °C, 0.5 hour; 100 cycles, 1 hour/cycle	
High Temperature Operation Test	50 °C, 240 hours	
Low Temperature Operation Test	0 °C, 240 hours	
High Temperature & High Humidity Operation Test	50 °C, 80% RH, 240 hours	
ESD Test (Operation)	150 pF, 330 Ω, 1 sec/cycle Condition 1: Contact Discharge, ± 8 kV Condition 2: Air Discharge, ± 15 kV	(1)
Shock (Non-operating)	220 G, 2 ms, half sine wave, 1 time for each direction of ±X, ±Y, ±Z	(1), (3)
Vibration (Non-operating)	1.5 G / 10-500 Hz, sine wave, 30 min/cycle, 1 cycle for each X, Y, Z	(1), (3)

Note (1) Criteria: Normal display image with no obvious non-uniformity and no line defect

Note (2) Evaluation should be tested after storage at room temperature for more than 2 hours.

Note (3) At testing vibration and shock, the fixture holding the module has to be hard and rigid enough so that the module is not twisted or bent by the fixture.

The fixture configuration is shown below:

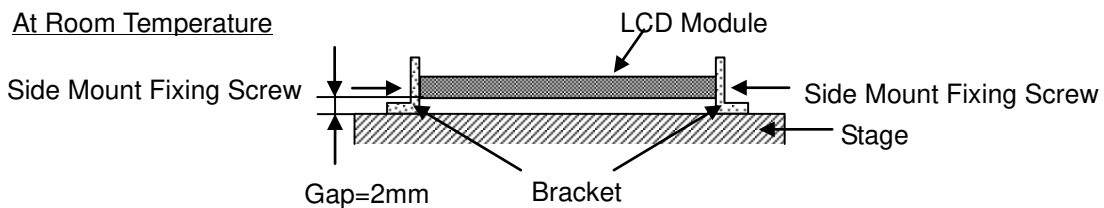



## 6 PRECAUTIONS

### 6.1 SYSTEM MATCHING PRECAUTIONS

- (1) Refer to the drawing.
- (2) To avoid wireless noise interference, please keep the antenna away from LCD control board.

### 6.2 HANDLING PRECAUTIONS

- (1) The module should be assembled into the system firmly by using every mounting hole. Be careful not to twist or bend the module.
- (2) While assembling or installing modules, it can only be in the clean area. The dust and oil may cause electrical short or damage the polarizer.
- (3) Use fingerstalls or soft gloves in order to keep display clean during the incoming inspection and assembly process.
- (4) Do not press or scratch the surface harder than a HB pencil lead on the panel because the polarizer is very soft and easily scratched.
- (5) If the surface of the polarizer is dirty, please clean it by some absorbent cotton or soft cloth. Do not use Ketone type materials (ex. Acetone), Ethyl alcohol, Toluene, Ethyl acid or Methyl chloride. It might permanently damage the polarizer due to chemical reaction.
- (6) Wipe off water droplets or oil immediately. Staining and discoloration may occur if they left on panel for a long time.
- (7) If the liquid crystal material leaks from the panel, it should be kept away from the eyes or mouth. In case of contacting with hands, legs or clothes, it must be washed away thoroughly with soap.
- (8) Protect the module from static electricity; it may cause damage to the C-MOS Gate Array IC.
- (9) Do not disassemble the module.
- (10) Do not pull or fold the LED wire.
- (11) Pins of I/F connector should not be touched directly with bare hands.

### 6.3 STORAGE PRECAUTIONS

- (1) High temperature or humidity may reduce the performance of module. Please store LCD module within the specified storage conditions.
- (2) It is dangerous that moisture come into or contacted the LCD module, because the moisture may damage LCD module when it is operating.
- (3) It may reduce the display quality if the ambient temperature is lower than 10 °C. For example, the response time will become slower.

### 6.4 OPERATION PRECAUTIONS

- (1) Do not pull the interface connector in or out while the module is operating.
- (2) Always follow the correct power on/off sequence when LCD module is connecting and operating. This can prevent the CMOS LSI chips from damage during latch-up.
- (3) Do not disassemble the module or insert anything into the backlight unit.

### 6.5 OTHER PRECAUTIONS

- (1) When fixed patterns are displayed for a long time, remnant image is likely to occur.



## 7 PACKING 7.1 CARTON

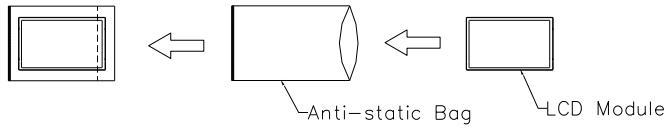

Box Dimensions : 435(L)\*350(W)\*320(H)  
Weight: Approx. 10.4kg(40 module .per. 1 box)

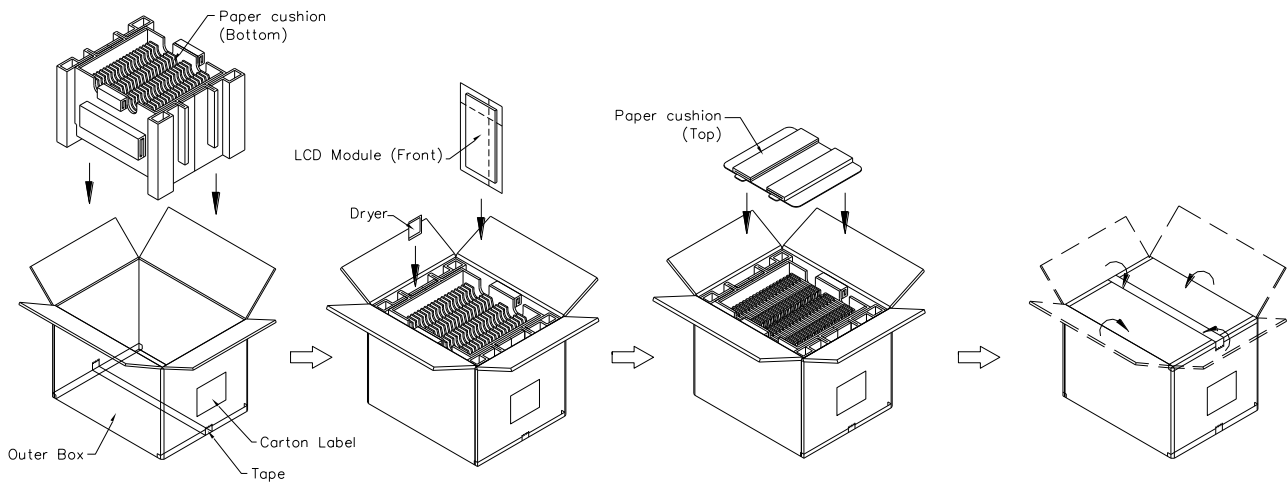



## 7.2 PALLET

Sea & Land Transportation

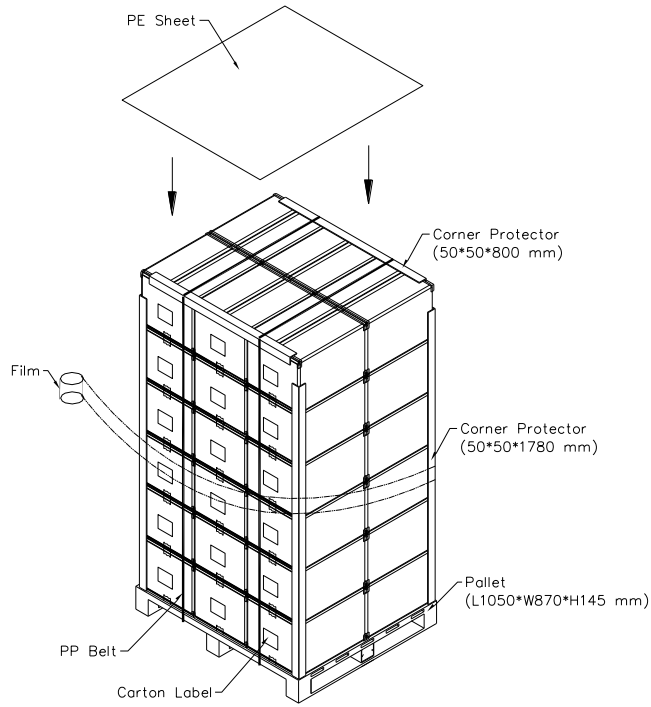

Air Transportation

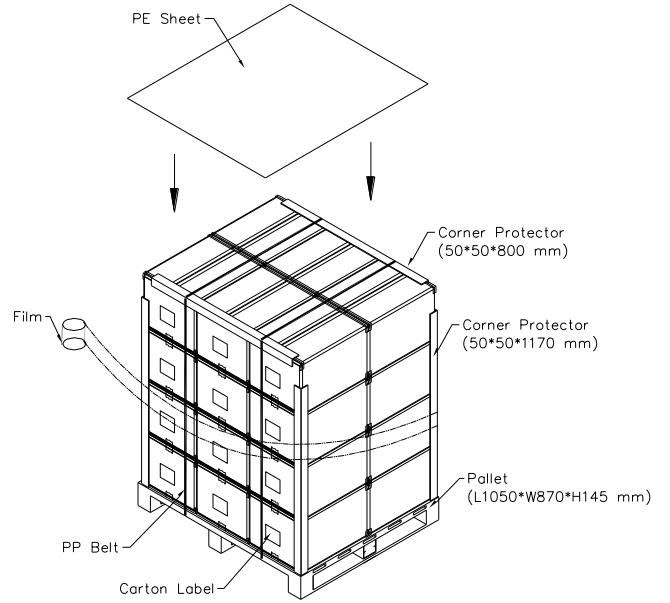



## 8 DEFINITION OF LABELS

### 8.1 MODULE LABEL

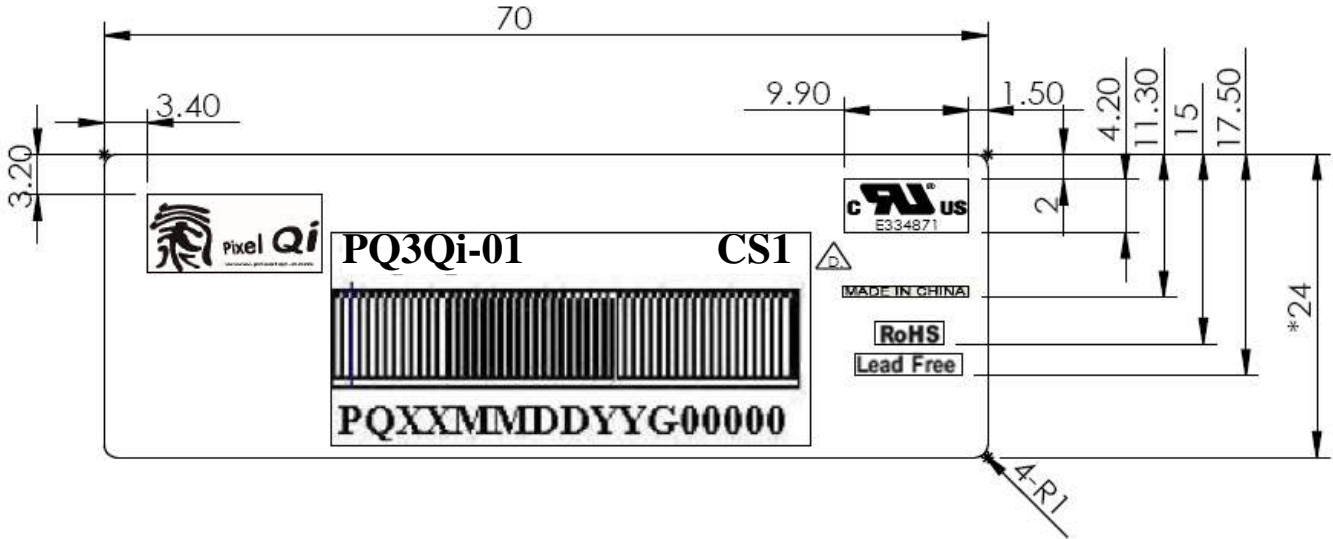



(D) Manufactured Date : Year: 01~99 , for 2001~2099

Month:01~12, for Jan~Dec.

Date: 01~31 for 1<sup>st</sup>~31<sup>st</sup>



8.2 CARTON LABEL

	<b>Pixel Qi</b>
PO.NO. _____	
Part ID. _____	
Model Name _____	
Carton ID. _____	Quantities _____
<a href="http://www.pixelqi.com">www.pixelqi.com</a>	 <b>RoHS</b>

Model Name: PQ 3Qi-01





### Appendix EDID DATA STRUCTURE

The EDID (Extended Display Identification Data) data formats are to support displays as defined in the VESA Plug & Display and FPGI standards. These values are subject to change.

Byte # (decimal)	Byte # (hex)	Field Name and Comments	Value (hex)	Value (binary)
0	0	Header	00	00000000
1	1	Header	FF	11111111
2	2	Header	FF	11111111
3	3	Header	FF	11111111
4	4	Header	FF	11111111
5	5	Header	FF	11111111
6	6	Header	FF	11111111
7	7	Header	00	00000000
8	8	EISA ID manufacturer name ("PQI")	42	01000010
9	9	EISA ID manufacturer name (Compressed ASCII)	29	00101001
10	0A	ID product code (N101L8-L01)	08	00001000
11	0B	ID product code (hex LSB first; N101L8-L01)	10	00010000
12	0C	ID S/N (fixed "0")	00	00000000
13	0D	ID S/N (fixed "0")	00	00000000
14	0E	ID S/N (fixed "0")	00	00000000
15	0F	ID S/N (fixed "0")	00	00000000
16	10	Week of manufacture (fixed week code)	28	00101000
17	11	Year of manufacture (fixed year code)	13	00010011
18	12	EDID structure version # ("1")	01	00000001
19	13	EDID revision # ("3")	03	00000011
20	14	Video I/P definition ("digital")	80	10000000
21	15	Max H image size ("22.272cm")	16	00010110
22	16	Max V image size ("12.528cm")	0C	00001100
23	17	Display Gamma (Gamma = "2.2")	78	01111000
24	18	Feature support ("RGB Color")	0A	00001010
25	19	Rx1, Rx0, Ry1, Ry0, Gx1, Gx0, Gy1, Gy0	A3	10100011
26	1A	Bx1, Bx0, By1, By0, Wx1, Wx0, Wy1, Wy0	95	10010101
27	1B	Rx=0.549	8C	10001100
28	1C	Ry=0.342	57	01010111
29	1D	Gx=0.324	53	01010011
30	1E	Gy=0.550	8C	10001100
31	1F	Bx=0.158	28	00101000
32	20	By=0.161	29	00101001
33	21	Wx=0.313	50	01010000
34	22	Wy=0.341	57	01010111
35	23	Established timings 1	00	00000000
36	24	Established timings 2	00	00000000
37	25	Manufacturer's reserved timings	00	00000000
38	26	Standard timing ID # 1	01	00000001
39	27	Standard timing ID # 1	01	00000001



Byte # (decimal)	Byte # (hex)	Field Name and Comments	Value (hex)	Value (binary)
40	28	Standard timing ID # 2	01	00000001
41	29	Standard timing ID # 2	01	00000001
42	2A	Standard timing ID # 3	01	00000001
43	2B	Standard timing ID # 3	01	00000001
44	2C	Standard timing ID # 4	01	00000001
45	2D	Standard timing ID # 4	01	00000001
46	2E	Standard timing ID # 5	01	00000001
47	2F	Standard timing ID # 5	01	00000001
48	30	Standard timing ID # 6	01	00000001
49	31	Standard timing ID # 6	01	00000001
50	32	Standard timing ID # 7	01	00000001
51	33	Standard timing ID # 7	01	00000001
52	34	Standard timing ID # 8	01	00000001
53	35	Standard timing ID # 8	01	00000001
54	36	Detailed timing description # 2 40Hz Timing Pixel clock ("29.31MHz", According to VESA CVT Rev1.1)	2D	00101101
55	37	# 2 40Hz Timing Pixel clock (hex LSB first)	11	00010001
56	38	# 2 40Hz Timing H active ("1024")	00	00000000
57	39	# 2 40Hz Timing H blank ("160")	A0	10100000
58	3A	# 2 40Hz Timing H active : H blank ("1024 : 160")	40	01000000
59	3B	# 2 40Hz Timing V active ("600")	58	01011000
60	3C	# 2 40Hz Timing V blank ("19")	13	00010011
61	3D	# 2 40Hz Timing V active : V blank ("600 :19")	20	00100000
62	3E	# 2 40Hz Timing H sync offset ("48")	30	00110000
63	3F	# 2 40Hz Timing H sync pulse width ("32")	20	00100000
64	40	# 2 40Hz Timing V sync offset : V sync pulse width ("3 : 10")	3A	00111010
65	41	# 2 40Hz Timing H sync offset : H sync pulse width : V sync offset : V sync width ("48: 32 : 3 : 10")	00	00000000
66	42	# 2 40Hz Timing H image size ("222 mm")	DE	11011110
67	43	# 2 40Hz Timing V image size ("125 mm")	7D	01111101
68	44	# 2 40Hz Timing H image size : V image size ("222 : 125")	00	00000000
69	45	# 2 40Hz Timing H boarder ("0")	00	00000000
70	46	# 2 40Hz Timing V boarder ("0")	00	00000000
71	47	# 2 40Hz Timing Non-interlaced ; Normal display, no stereo ; Digital Separate ; V sync POL is negative ; H sync POL is positive	18	00011000
72	48	Detailed timing description # 1 Pixel clock ("43.97MHz", According to VESA CVT Rev1.1)	74	01110100
73	49	# 1 Pixel clock (hex LSB first)	0B	00001011
74	4A	# 1 H active ("1024")	00	00000000
75	4B	# 1 H blank ("160")	A0	10100000
76	4C	# 1 H active : H blank ("1024 : 160")	40	01000000
77	4D	# 1 V active ("600")	58	01011000
78	4E	# 1 V blank ("19")	13	00010011
79	4F	# 1 V active : V blank ("600 :19")	20	00100000
80	50	# 1 H sync offset ("48")	30	00110000



Byte # (decimal)	Byte # (hex)	Field Name and Comments	Value (hex)	Value (binary)
81	51	# 1 H sync pulse width ("32")	20	00100000
82	52	# 1 V sync offset : V sync pulse width ("3 : 10")	3A	00111010
83	53	# 1 H sync offset : H sync pulse width : V sync offset : V sync width ("48: 32 : 3 : 10")	00	00000000
84	54	# 1 H image size ("222 mm")	DE	11011110
85	55	# 1 V image size ("125 mm")	7D	01111101
86	56	# 1 H image size : V image size ("222 : 125")	00	00000000
87	57	# 1 H boarder ("0")	00	00000000
88	58	# 1 V boarder ("0")	00	00000000
89	59	# 1 Non-interlaced, Normal, no stereo, Separate sync, H/V pol Negatives	18	00011000
90	5A	Detailed timing description # 3 30Hz Timing Pixel clock ("21.99MHz", According to VESA CMT Rev1.1)	97	10010111
91	5B	# 3 30Hz Timing Pixel clock (hex LSB first)	08	00001000
92	5C	# 3 30Hz Timing H active ("1024")	00	00000000
93	5D	# 3 30Hz Timing H blank ("160")	A0	10100000
94	5E	# 3 30Hz Timing H active : H blank ("1024 : 160")	40	01000000
95	5F	# 3 30Hz Timing V active ("600")	58	01011000
96	60	# 3 30Hz Timing V blank ("19")	13	00010011
97	61	# 3 30Hz Timing V active : V blank ("600 :19")	20	00100000
98	62	# 3 30Hz Timing H sync offset ("48")	30	00110000
99	63	# 3 30Hz Timing H sync pulse width ("32")	20	00100000
100	64	# 3 30Hz Timing V sync offset : V sync pulse width ("3 : 10")	3A	00111010
101	65	# 3 30Hz Timing H sync offset : H sync pulse width : V sync offset : V sync width ("48: 32 : 3 : 10")	00	00000000
102	66	# 3 30Hz Timing H image size ("222 mm")	DE	11011110
103	67	# 3 30Hz Timing V image size ("125 mm")	7D	01111101
104	68	# 3 30Hz Timing H image size : V image size ("222 : 125")	00	00000000
105	69	# 3 30Hz Timing H boarder ("0")	00	00000000
106	6A	# 3 30Hz Timing V boarder ("0")	00	00000000
107	6B	# 3 30Hz Timing Non-interlaced ; Normal display, no stereo ; Digital Separate ; V sync POL is negative ; H sync POL is positive	18	00011000
108	6C	Detailed timing description # 4	00	00000000
109	6D	# 4 Flag	00	00000000
110	6E	# 4 Reserved	00	00000000
111	6F	# 4 FE (hex) defines ASCII string (Model Name"PQ3Qi-01", ASCII)	FE	11111110
112	70	# 4 Flag	00	00000000
113	71	# 4 1st character of name ("P")	50	01010000
114	72	# 4 2nd character of name ("Q")	51	01010001
115	73	# 4 3rd character of name ("3")	33	00110011
116	74	# 4 4th character of name ("Q")	51	01010001
117	75	# 4 5th character of name ("i")	69	01101001
118	76	# 4 6th character of name ("-")	2D	00101101
119	77	# 4 7th character of name ("0")	30	00110000
120	78	# 4 8th character of name ("1")	31	00110001



Byte # (decimal)	Byte # (hex)	Field Name and Comments	Value (hex)	Value (binary)
121	79	# 4 New line character indicates end of ASCII string	0A	00001010
122	7A	# 4 Padding with "Blank" character	20	00100000
123	7B	# 4 Padding with "Blank" character	20	00100000
124	7C	# 4 Padding with "Blank" character	20	00100000
125	7D	# 4 Padding with "Blank" character	20	00100000
126	7E	Extension flag	00	00000000
127	7F	Checksum	E5	11100101