

EF1 Series

Simple Assembly In-Line Power Connectors for up to 160A



Round Terminal



High-Current



1 Touch Locking

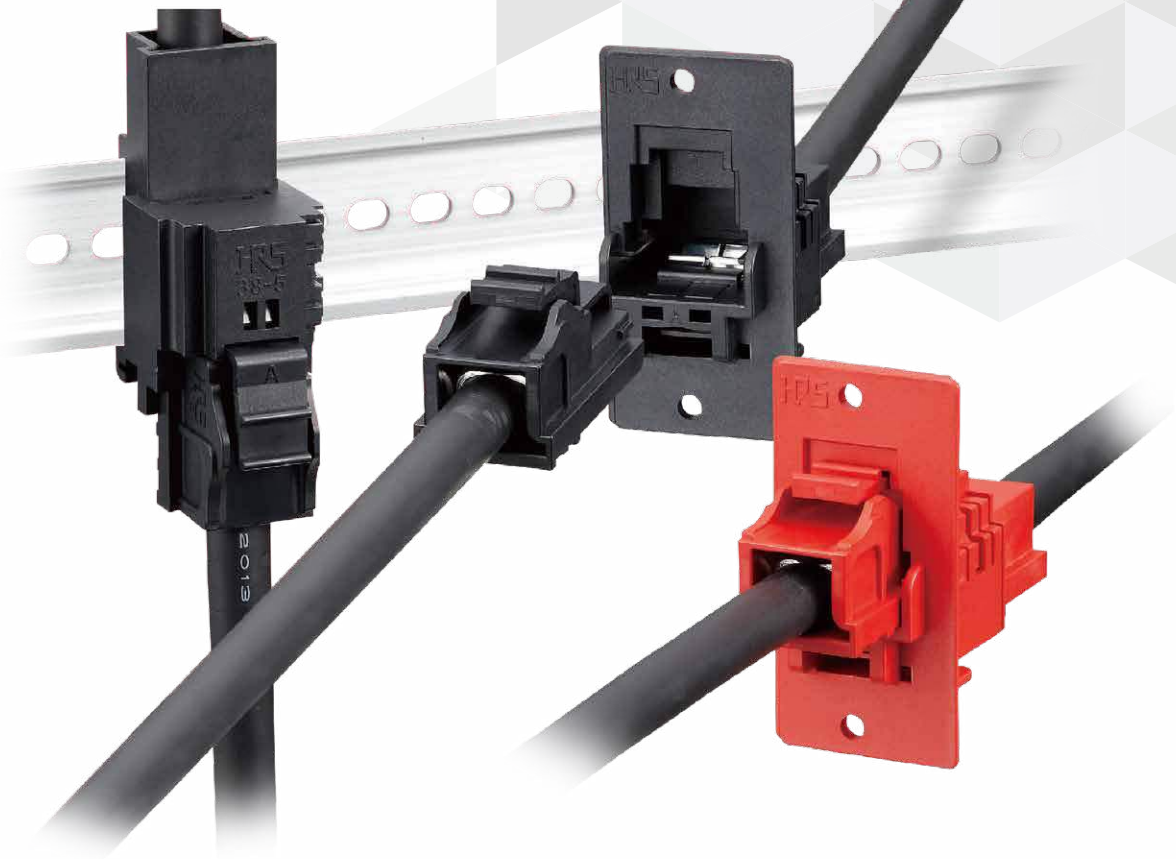

Features

1. Connection by simply inserting the ring terminal into the case

Connection is completed with only a few labor steps by simply crimping the contact to the power cable and inserting to the housing.

2. Quick snap-in lock, no screw retightening

The snap-in mating design reduces the number of cable routing steps. Since the connector does not use screws, there is no risk of loosening.

3. Rated Current of 160A when using 38mm² cable

The conductor diameter of 5.5, 8, 14 and 22mm² cables can be converted to 38mm² by using a sleeve.

4. Choice of two mounting options: DIN rail attachment or panel

This connector is versatile enough to be used in a wide range of mounting applications.

5. Simplified crimp termination

No special tools are required.

6. Equipped with guide keys

Guide keys are used to prevent incorrect wiring.

7. TÜV, UL certified

8. RoHS compliant

Product Specifications

| | | | |
|------------------------|--------------------------|--------------------------------|--------------|
| Rated Current (Note 1) | 2 AWG, 38mm ² | Operating Temperature (Note 2) | -25 ~ +105°C |
| | 160A | Storage Temperature Range | -10 ~ +60°C |
| Rated Voltage | AC/DC 1000V | | |

| | | | | | | | | |
|----|------------------------|--------------------------|--------------------------|--------------------------|-------------------------|----------------------------|--------------------------------|--------------|
| UL | Rated Current (Note 1) | 2 AWG, 38mm ² | 4 AWG, 22mm ² | 6 AWG, 14mm ² | 8 AWG, 8mm ² | 10 AWG, 5.5mm ² | Operating Temperature (Note 2) | -25 ~ +105°C |
| | | 130A | 94A | 70A | 50A | 40A | Storage Temperature Range | -10 ~ +60°C |
| | Rated Voltage | AC/DC 600V | | | | | | |

| | | | | | | | | |
|-----|------------------------|--------------------------|--------------------------|--------------------------|-------------------------|----------------------------|--------------------------------|--------------|
| TÜV | Rated Current (Note 1) | 2 AWG, 38mm ² | 4 AWG, 22mm ² | 6 AWG, 14mm ² | 8 AWG, 8mm ² | 10 AWG, 5.5mm ² | Operating Temperature (Note 2) | -25 ~ +105°C |
| | | 130A | 94A | 70A | 50A | 40A | Storage Temperature Range | -10 ~ +60°C |
| | Rated Voltage | AC/DC 600V | | | | | | |

Note 1 : The rated current value varies depending on the ambient temperature in which the connector is used. It is recommended to use the product within the derating curve zone (dashed lines).

When using a UL or TÜV approved product, please use the product within the specified range as well as the derating curve area.

Note 2 : Includes the temperature rise due to current flow.

| Items | Specifications | Conditions |
|------------------------------------|---|---|
| Contact Resistance | 0.5mΩ Max. | Measured with 1A DC |
| Insulation Resistance | 1,000MΩ Min. | Measured with 500V DC |
| Withstanding Voltage | No flashover or breakdown | 3310V AC for 1 min. |
| Mating Durability | Contact Resistance : 1mΩ Max. Inserting and Extracting Force : 150N Max. | 30 mating cycles |
| Temperature Cycles | Insulation Resistance : 1,000MΩ Min. | -55°C : 30 minutes → Room temperature : 2 to 3 minutes → 105°C : 30 minutes → Room temperature : 2 to 3 minutes 5 cycles |
| Salt Water Spray | No functional problems | Left for 48 hours in 5% concentration of salt water |
| Humidity Resistance (Steady State) | Insulation Resistance : 10MΩ Min. (in high humidity) 100MΩ Min. (dry) | Temperature 40°C , humidity 90 to 95%, 96 hours |

[Reference] Derating Curve and Temperature Rise Curve

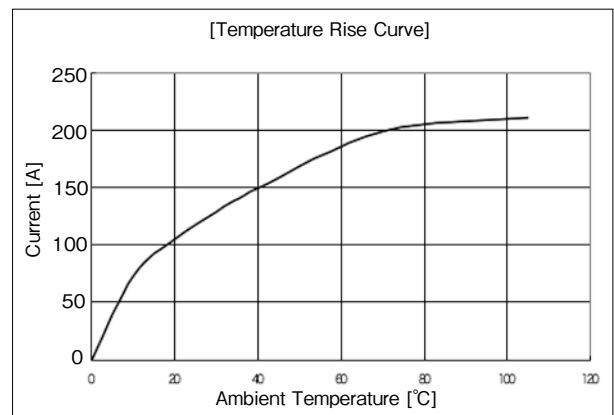
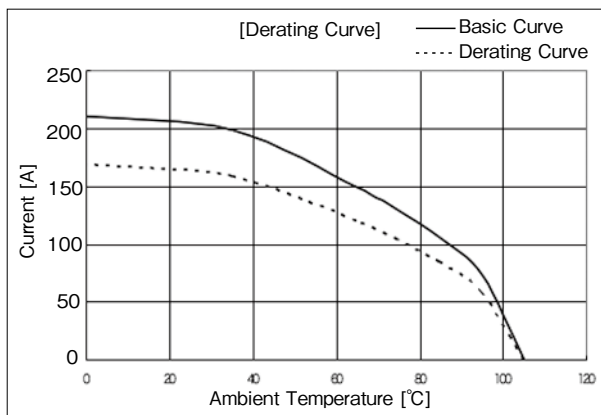

Note 1 : The derating curve is derived from the basic curve multiplied by the derating factor of 0.8.

Note 2 : The derating curve and temperature rise curve are measured under the following conditions:

- Product unused prior to testing
- Cable conductor cross-sectional area : 38mm² (2 AWG)
- Measured with power supplied in stationary state

Material / Finish

| Component | Material | Finish | Remarks |
|----------------|--------------|--------------------|---------|
| Insulator | PBT Resin | Black, Red or Blue | UL94V-0 |
| Contact Spring | Copper Alloy | Tin Plated | - |
| Contact | | | |
| Sleeve | | | |

Product Number Structure

Refer to the chart below when determining the product specifications from the product number.
Please select from the product numbers listed in this catalog when placing orders.

Connector

EF 1 - 38 R A - 1 S C A (##)

① ② ③ ④ ⑤ ⑥ ⑦ ⑧ ⑨

Sleeve

EF 1 - 38 - 22 (##)

① ② ⑩ ⑨

| | | | |
|------------------|---|------------------------------|---|
| ① Series Name | EF1 | ⑥ Connector Design | S : Spring Contact Side P : Non-spring Contact Side |
| ② Contact Size | 38 : 38-5 size contact | ⑦ Contact Termination Method | C : Crimp Termination |
| ③ Connector Type | P : Plug R : Receptacle None : Sleeve | ⑧ Mating Guide Display | 4 different keying options available from A to D |
| ④ Serial Symbol | | ⑨ | Other specification differences are noted with (01), (02)... to distinguish certain variations. |
| ⑤ No. of Pos. | 1 | ⑩ Supported Cables | 22 : Supports a cable with conductor cross-sectional area equivalent to 22mm ² 14 : Supports a cable with conductor cross-sectional area equivalent to 14mm ² 8 : Supports a cable with conductor cross-sectional area equivalent to 5.5 and 8mm ² |

Receptacle (DIN Rail Mount Type)

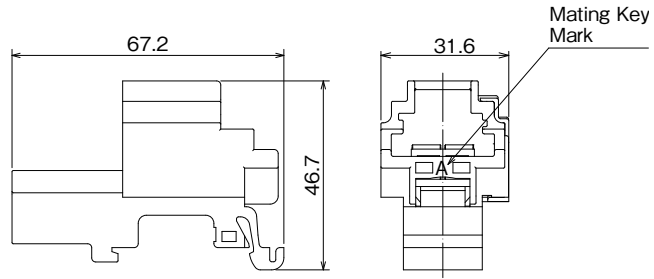

Unit : mm

| Part No. | HRS No. | Purchase Unit | Remarks |
|------------------|------------------|---------------|---------|
| EF1-38R-1SCA(20) | CL0142-0001-3-20 | 10pcs per bag | - |
| EF1-38R-1SCB(20) | CL0142-0009-5-20 | | |
| EF1-38R-1SCC(20) | CL0142-0011-7-20 | | |
| EF1-38R-1SCD(20) | CL0142-0013-2-20 | | |

Receptacle (Panel Mount Type)

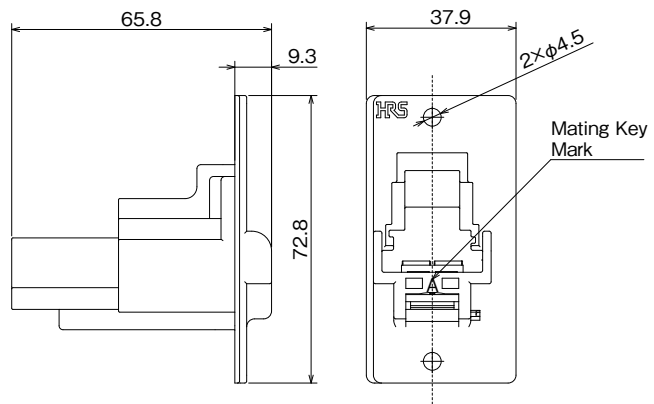

Unit : mm

| Part No. | HRS No. | Purchase Unit | Remarks |
|-------------------|------------------|---------------|--------------|
| EF1-38RA-1SCA(20) | CL0142-0003-9-20 | 10pcs per bag | - |
| EF1-38RA-1SCA(30) | CL0142-0003-9-30 | | Color : Red |
| EF1-38RA-1SCB(20) | CL0142-0004-1-20 | | - |
| EF1-38RA-1SCB(31) | CL0142-0004-1-31 | | Color : Blue |
| EF1-38RA-1SCC(20) | CL0142-0015-8-20 | | - |
| EF1-38RA-1SCD(20) | CL0142-0016-0-20 | | - |
| EF1-38RA-1SCD(30) | CL0142-0016-0-30 | | Color : Red |

Plug

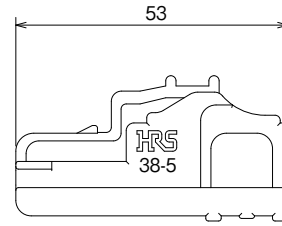
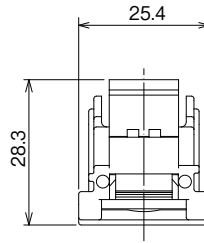

Unit : mm

| Part No. | HRS No. | Purchase Unit | Remarks |
|------------------|------------------|---------------|-------------|
| EF1-38P-1PCA | CL0142-0002-6-00 | 10pcs per bag | - |
| EF1-38P-1PCA(10) | CL0142-0002-6-10 | | Color : Red |
| EF1-38P-1PCB | CL0142-0005-4-00 | | - |
| EF1-38P-1PCC | CL0142-0010-4-00 | | - |
| EF1-38P-1PCD | CL0142-0012-0-00 | | - |

Sleeve

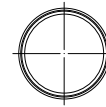
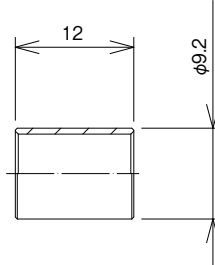

Unit : mm

| Part No. | HRS No. | Purchase Unit | Conductor Cross-Sectional Area of Applicable Cable | Rated Current |
|-----------|------------------|----------------|--|---------------|
| EF1-38-22 | CL0142-0006-7-00 | 100pcs per bag | 22mm ² | 94A |
| EF1-38-8 | CL0142-0007-0-00 | | ① 8mm ² , ② 5.5mm ² | ① 50A, ② 40A |
| EF1-38-14 | CL0142-0008-2-00 | | 14mm ² | 70A |

Panel Cut-Out Dimensions from Receptacle Mounted Side

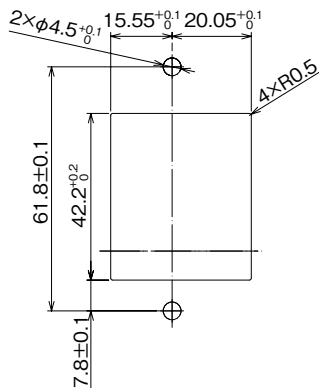

Single Mounting

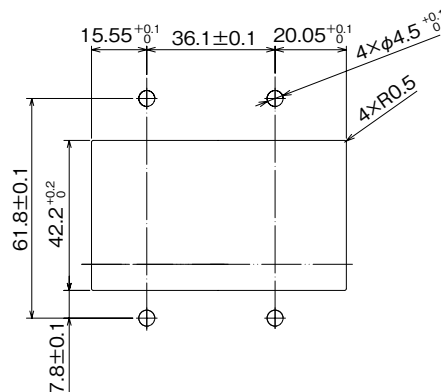

Dual Mounting



Recommended Crimp Tools

| | | |
|----------|--|--|
| |  |  |
| Type | Manual Hydraulic Type Crimp Tool | Electric Hydraulic Type Crimp Tool |
| Part No. | HT111/9H-60 | HT112/REC-150F |
| HRS No. | CL0902-1515-2-00 | CL0902-1516-5-00 |
| Remarks | Equivalent Product : 9H-60 made by Maxell Izumi Co., Ltd. | Equivalent Product : REC-150F made by Maxell Izumi Co., Ltd. |

Note : Please perform regular maintenance on the crimp tool based on the instruction manual.

Safety Precautions

⚠ Warning

- Do not touch the exposed conductor while it is energized, failing to follow this warning may cause an electric shock and injury. ⚠
- The power should be in the OFF position when inserting or extracting this connector.
- To check for correct connector mating, lightly pull on the cable and make sure the connector does not come off. Incomplete mating may result in significant danger such as disconnection or contact failure.

⚠ Caution

- This connector was designed to be used in a stable and stationary environment, do not try to operate this connector where vibration will occur.
- Please use only Hirose approved contacts. Use of a non-specified contact may lower product performance and result in serious accident. Please contact your Hirose representative for additional information.

Mechanical Strength (EF1-38R-1SC#)

(1) Cable Routing

When wiring, fasten the cables in order to prevent a load to the connector. Avoid surpassing the specified values shown in the cable routing direction diagram below in order to prevent connector breakage.

Tolerable Mechanical Stress to Cables (Reference)

- ①, ③, ④, ⑥, ⑦, ⑧ direction : 20N Max.
- ② direction : 150N Max.
- ⑤ direction : 200N Max.

Note : The mechanical stress varies depending on cable types.

When using a hard type cable in particular, make sure not to break the lock arm.

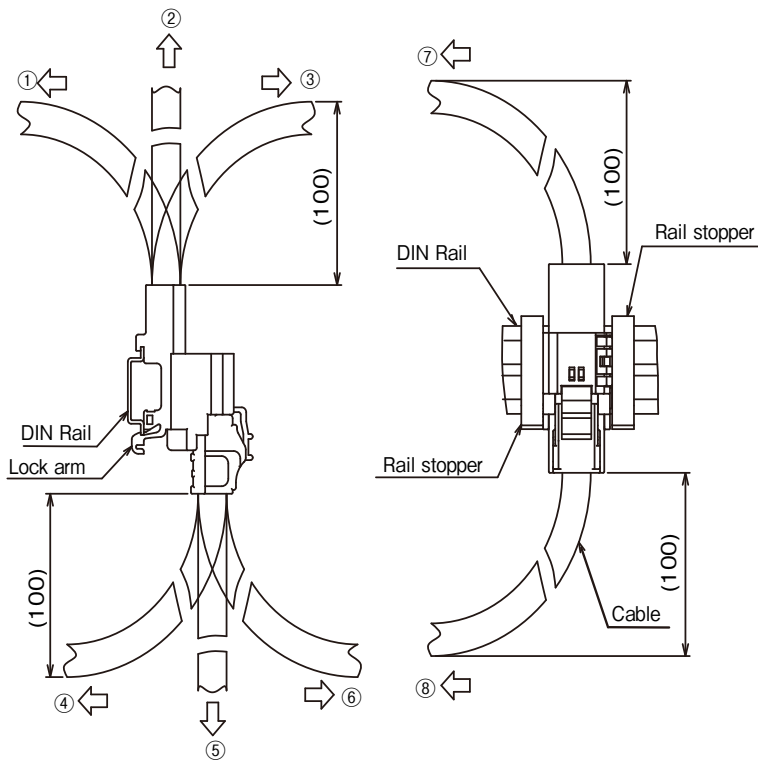

(2) After Wiring

Stabilize the cable with cable ties, etc. to prevent direct vibration and shock to the connector. Securing the cables within 100mm distance from the connector body is recommended.

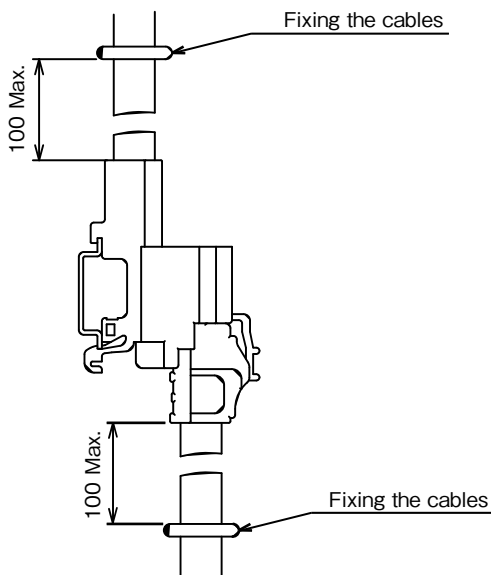

While taking in consideration

Specifications mentioned in this catalog are reference values.

When considering to order or use this product, please confirm the "Drawing" and "Product Specifications" sheets.

Use an appropriate cable when using the connector in combination with cables.

If considering usage of a non-specified cable, please contact your sales representative.

If assembly process is done by jigs & tools which are not identified by Hirose assurance will not be given.

Please consult with your Hirose sales representative if you are planning to use the product for any of the following applications. (Automotive, medical, public infrastructure, aerospace/defense, etc.)

Hirose will consider the validity of the warranty depending on the conditions.

[JAPAN]

Headquarters

HIROSE ELECTRIC CO., LTD

Phone : +81-3-3491-7675
<http://www.hirose.com>

YOKOHAMA Center

HIROSE ELECTRIC CO., LTD

Phone : +81-45-620-3491
<http://www.hirose.com>

[USA]

U.S Headquarters / CHICAGO Office

HIROSE ELECTRIC (U.S.A.), INC.

Phone : +1-630-282-6700
<http://www.hirose.com/us/>

SAN JOSE Office

HIROSE ELECTRIC (U.S.A.), INC.

Phone : +1-408-253-9640
<http://www.hirose.com/us/>

DETROIT Office (AUTOMOTIVE)

HIROSE ELECTRIC (U.S.A.), INC.

Phone : +1-734-542-9963
<http://www.hirose.com/us/>

BOSTON Office

HIROSE ELECTRIC (U.S.A.), INC.

Phone : +1-978-655-9850
<http://www.hirose.com/us/>

DALLAS Office

HIROSE ELECTRIC (U.S.A.), INC.

Phone : +1-972-324-3370
<http://www.hirose.com/us/>

IRVINE Office

HIROSE ELECTRIC (U.S.A.), INC.

Phone : +1-949-930-3750
<http://www.hirose.com/us/>

[THE NETHERLANDS]

EU Headquarters / AMSTERDAM OFFICE

HIROSE ELECTRIC EUROPE B.V.

Phone : +31-20-6557460
<http://www.hirose.com/eu/>

[UNITED KINGDOM]

UK Branch

HIROSE ELECTRIC EUROPE B.V.

Phone : +44-1908-202050
<http://www.hirose.com/eu/>

[GERMANY]

GERMAN Branch / STUTTGART Office

HIROSE ELECTRIC EUROPE B.V.

Phone : +49-711-456002-1
<http://www.hirose.com/eu/>

NUREMBERG Office

HIROSE ELECTRIC EUROPE B.V.

Phone : +49-911-326889-63
<http://www.hirose.com/eu/>

HANOVER Office

HIROSE ELECTRIC EUROPE B.V.

Phone : +49-511-978261-30
<http://www.hirose.com/eu/>

[FRANCE]

PARIS Office

HIROSE ELECTRIC EUROPE B.V.

Phone : +33-1-85764886
<http://www.hirose.com/eu/>

[ITALY]

MILAN Office

HIROSE ELECTRIC EUROPE B.V.

Phone : +39-02-36636350
<http://www.hirose.com/eu/>

[CHINA]

CHINA Headquarters / SHANGHAI Branch

HIROSE ELECTRIC (CHINA) CO., LTD.

Phone : +86-21-6391-3355
<http://www.hirose.com/cn/>

SHENZHEN Branch

HIROSE ELECTRIC (CHINA) CO., LTD.

Phone : +86-755-8207-0851
<http://www.hirose.com/cn/>

BEIJING Branch

HIROSE ELECTRIC (CHINA) CO.,LTD.

Phone : +86-10-5165-9332
<http://www.hirose.com/cn/>

[HONG KONG]

HONG KONG Office

HIROSE ELECTRIC HONGKONG TRADING CO., LTD.

Phone : +852-2803-5338
<http://www.hirose.com/hk/>

[TAIWAN]

TAIWAN Office

HIROSE ELECTRIC (TAIWAN) CO., LTD.

Phone : +886-2-2555-7377
<http://www.hirose.com/tw/>

[KOREA]

KOREA Office

HIROSE KOREA CO.,LTD.

Phone : +82-31-496-7000
<http://www.hirose.co.kr/>

[SINGAPORE]

SINGAPORE Office

HIROSE ELECTRIC SINGAPORE PTE. LTD.

Phone : +65-6324-6113
<http://www.hirose.com/sg/>

[THAILAND]

BANGKOK Liaison Office

HIROSE ELECTRIC SINGAPORE PTE. LTD.

Phone : +66-2-686-1255
<http://www.hirose.com/sg/>

[MALAYSIA]

PENANG Representative Office

HIROSE ELECTRIC SINGAPORE PTE. LTD.

Phone : +60-4-648-5536
<http://www.hirose.com/sg/>

[INDIA]

BANGALORE Office

HIROSE ELECTRIC INDIA PVT. LTD.

Phone : +91-80-4120-1907
<http://www.hirose.com/sg/>

DELHI Office

HIROSE ELECTRIC INDIA PVT. LTD.

Phone : +91-120-660-8018
<http://www.hirose.com/sg/>

MEMO

A large rectangular area filled with a grid of dashed lines, intended for writing the content of the memo.

MEMO

A large rectangular area filled with a grid of dashed lines, intended for writing the content of the memo.