

THIS DRAWING IS UNPUBLISHED. RELEASED FOR PUBLICATION
 © COPYRIGHT 2017 BY TE CONNECTIVITY CORPORATION ALL RIGHTS RESERVED.

REVISIONS					
P	LTR	DESCRIPTION	DATE	DWN	APVD
1		INITIAL DRAWING	26NOV2016	VA	AT
2		UPDATED TO REFLECT COMPONENT CHANGES	30AUG2017	RGV	AT
A		REV PER ECR-18-012427	08AUG2018	MK	WS
A1		ECR-18-018118	16NOV2018	WS	AT

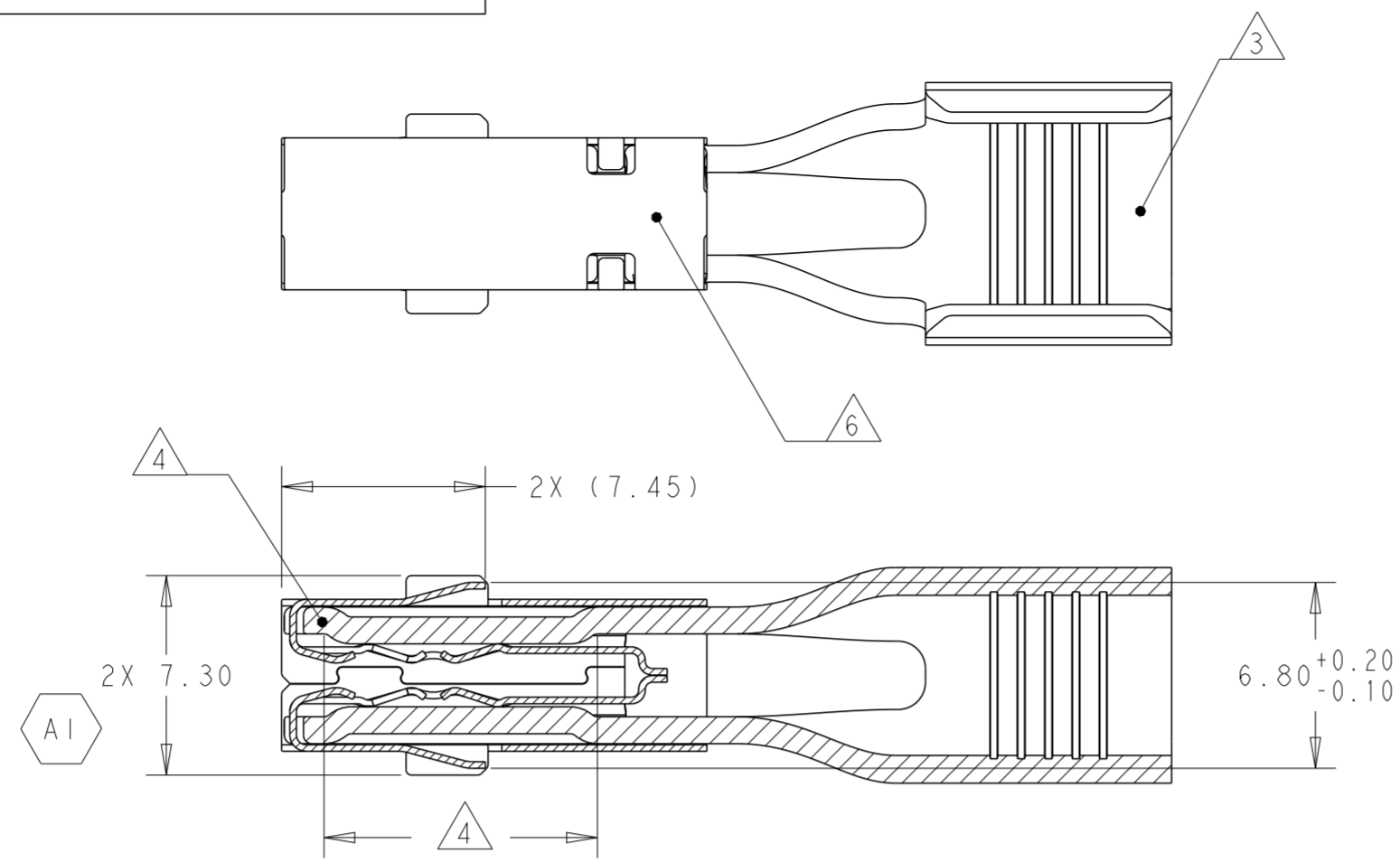

SECTION J-J

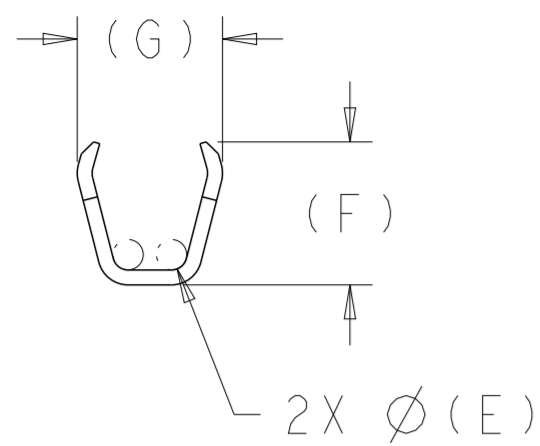
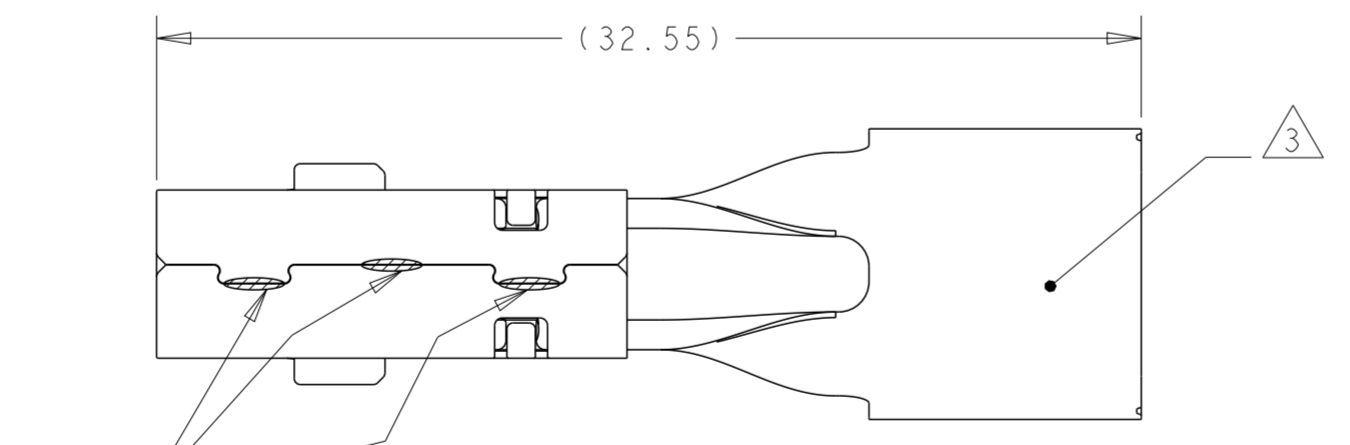
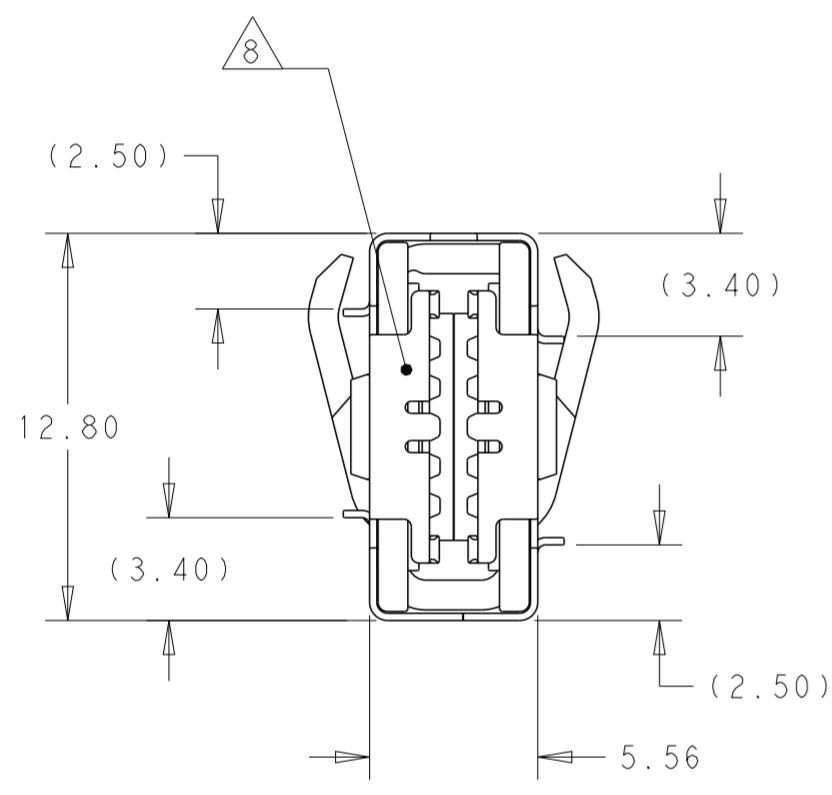
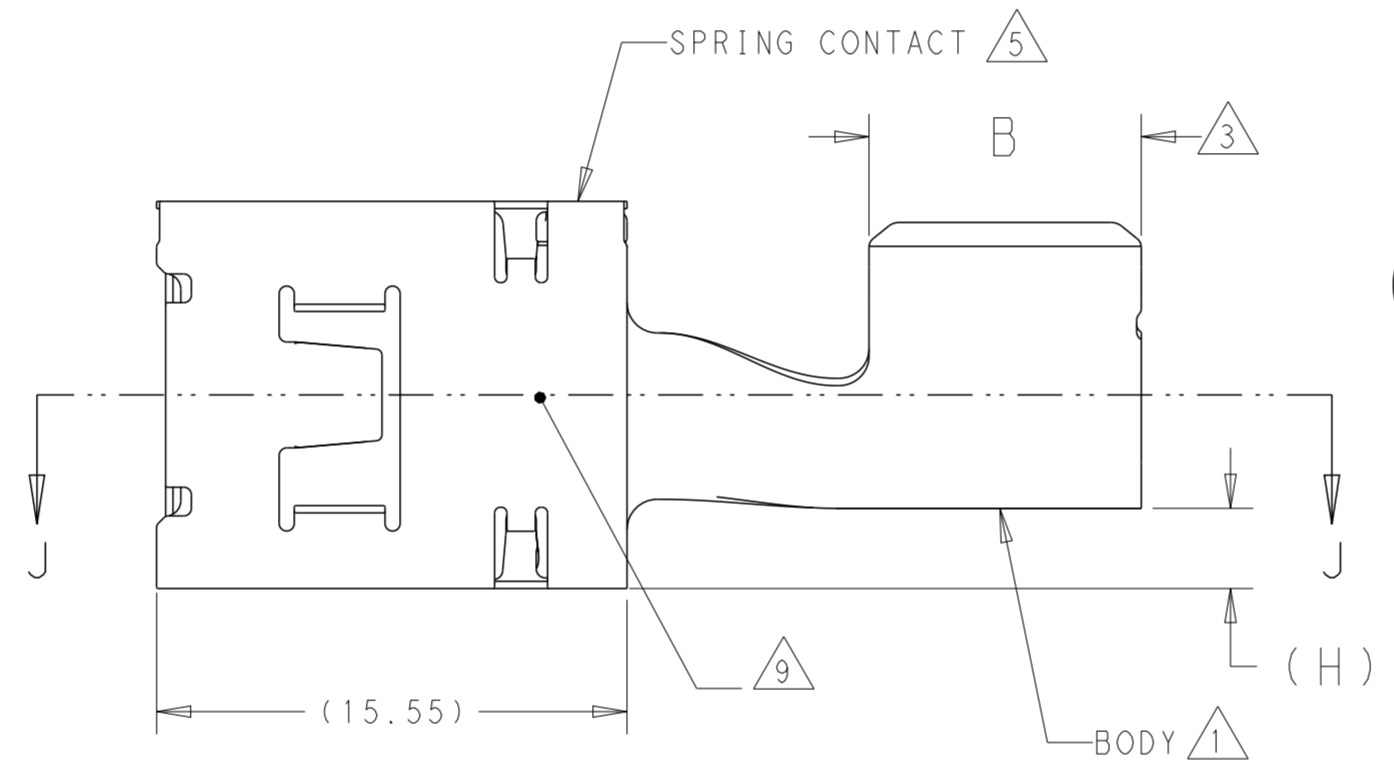

WELD

- 1 BODY MATERIAL: (1.00) THICK COPPER ALLOY
- 2. NOTE REMOVED
- 3 BODY FINISH: SELECTIVE TIN PLATING OVER NICKEL IN GRIP AREA
- 4 BODY FINISH: SELECTIVE SILVER PLATING OVER NICKEL IN CONTACT AREA
- 5 SPRING (0.25) THICK COPPER ALLOY
- 6 WEEK (YWW) LASER MARKED 0.65 HIGH CHARACTERS, LOCATED APPROX AS SHOWN
- 7 NOTE REMOVED
- 8 SPRING FINISH: SELECTIVE TIN OVER NICKEL PLATING
- 9 SPRING FINISH: SELECTIVE SILVER OVER NICKEL PLATING

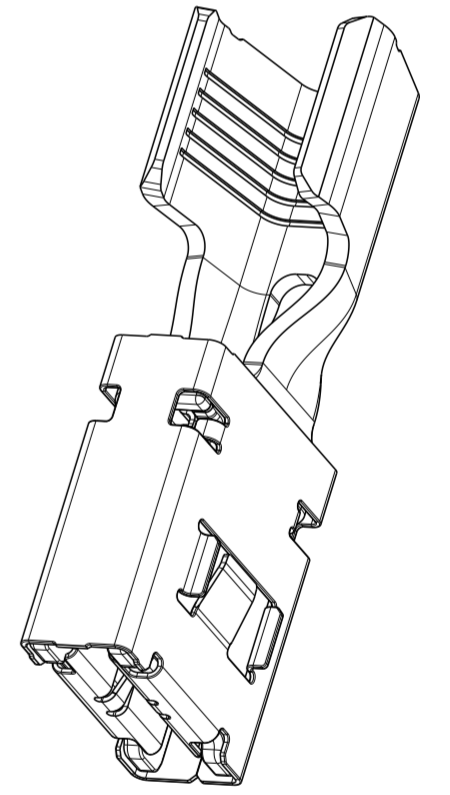
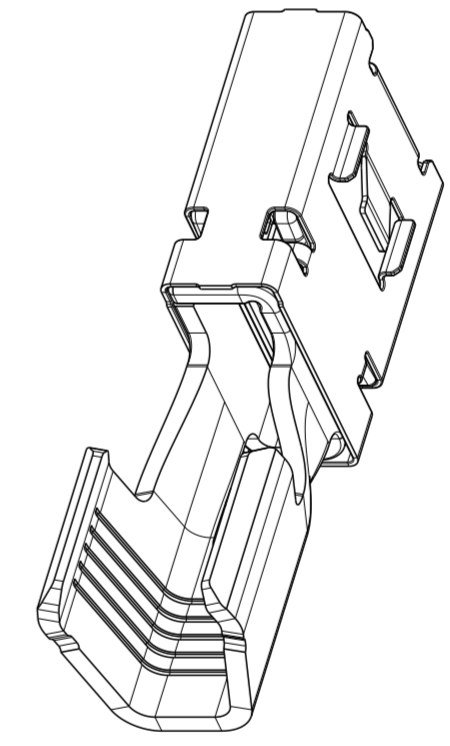
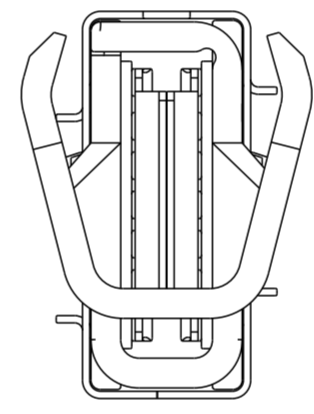

2.35	9.60	9.45	2.00	9.00	10-16	LOOSE PIECE	1-2840575-2	
3.10	7.80	8.00	2.00	7.00	5-8	LOOSE PIECE	1-2840575-1	
(H)	(G)	(F)	(E)	(B)	WIRE RANGE (mm ²)	DESCRIPTION	PART NO	REV

1-2840575-2 SHOWN

THIS DRAWING IS A CONTROLLED DOCUMENT.

DWN VISHWA A 26NOV2016	TE Connectivity
CHK A TYLER 26NOV2016	
APVD W. SAMSAIR 08AUG2018	
PRODUCT SPEC	
APPLICATION SPEC	NAME RECEPTACLE ASSY, 180 DEG. PCON12
WEIGHT 7.18g	SIZE A2 CAGE CODE 00779 DRAWING NO C-2840575
CUSTOMER DRAWING	RESTRICTED TO
	SCALE 4:1 SHEET 1 OF 1 REV A1