

LOC	DIST	REV	DATE	BY	CHK	APPV
AF	50	0	02MAR2004	RCF	JH	
		A	05APR2005	MF	RL	
		AI	12JUL2005	MF	RL	
		B	07JUN2006	HMR	RL	

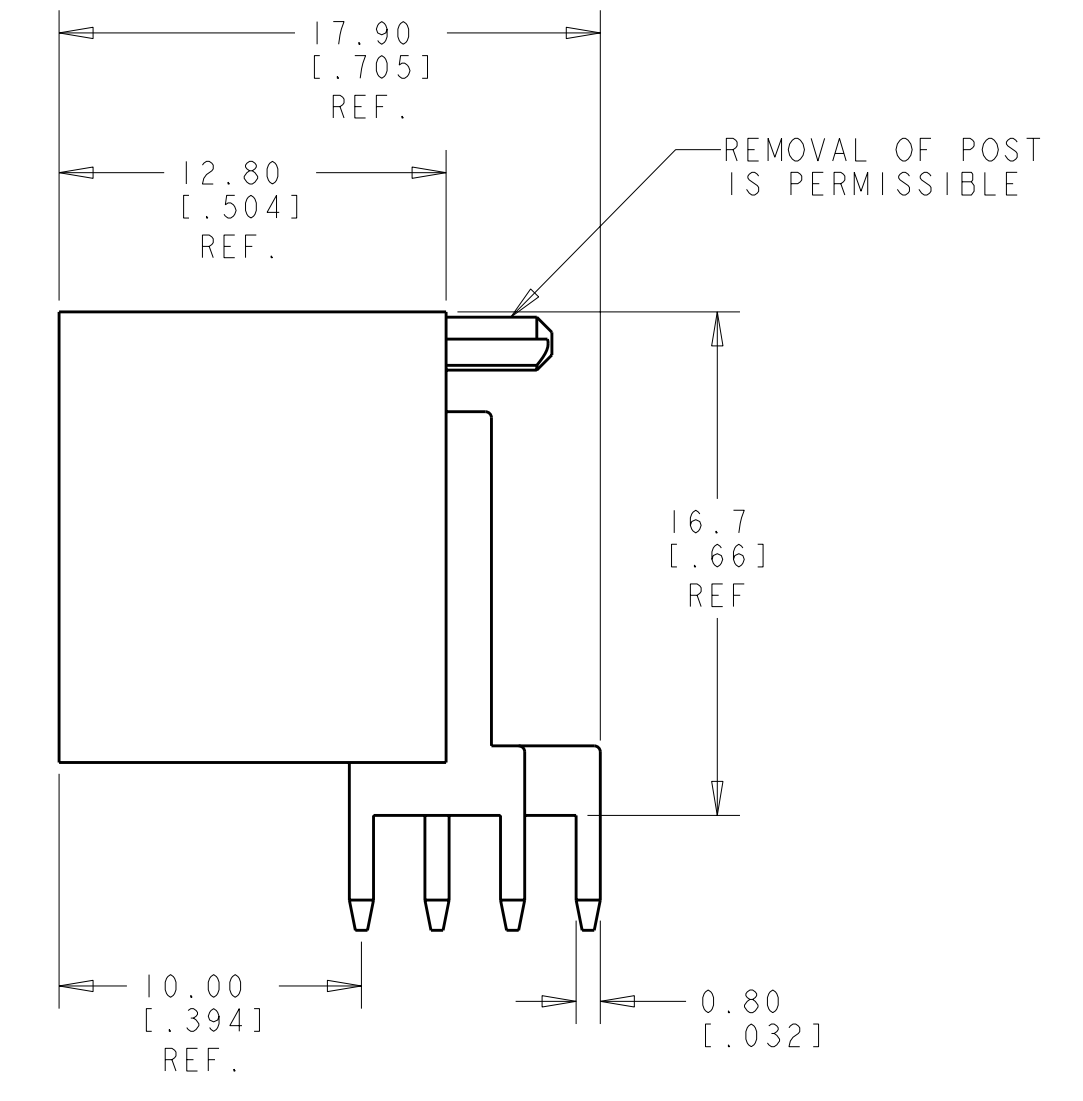

- 1 HOUSING HAS RAST 5 COMPLIANT KEYING, LATCHING, AND POLARIZATION. TAB IS 6.3 x 0.8 [.250 x .032], HOWEVER, THE LOCATION OF THE TAB HOLE DOES NOT MEET DIN 46244.
- 2 POSSIBLE TYCO MATING CONNECTOR FAMILIES INCLUDE POSITIVE-LOCK RAST 5, STANDARD TIMER RAST 5, MULTIFITTING, MULTIFITTING MK11, AND MONO-SHAPE TAB CONNECTORS.
- 3 MATERIAL: HOUSING, NYLON 66, UL 94V-0. CONTACT, BRASS, 0.8 mm THICK.
- 4 FINISH: CONTACTS, 3.8 μm MIN TIN OVER 1.3 μm MIN NICKEL.
- 5 PCB TABS INSERTED IN A STAGGERED PATTERN BEGINNING WITH POSITION 1.
- 6 SELECTED HOLES MAY BE 1.05+0.05/-0.00 DIA [.041+.002/-0.001 DIA] FOR IMPROVED (PRESS-FIT) RETENTION TO P.C.B. PRIOR TO SOLDERING.
- 7 DATUM AND BASIC DIMENSION ESTABLISHED BY CUSTOMER.
- 8 PRODUCT QUALIFICATION PER 108-2183.
- 9 PRE-PRODUCTION - F.A.S.R. REQUIRED.

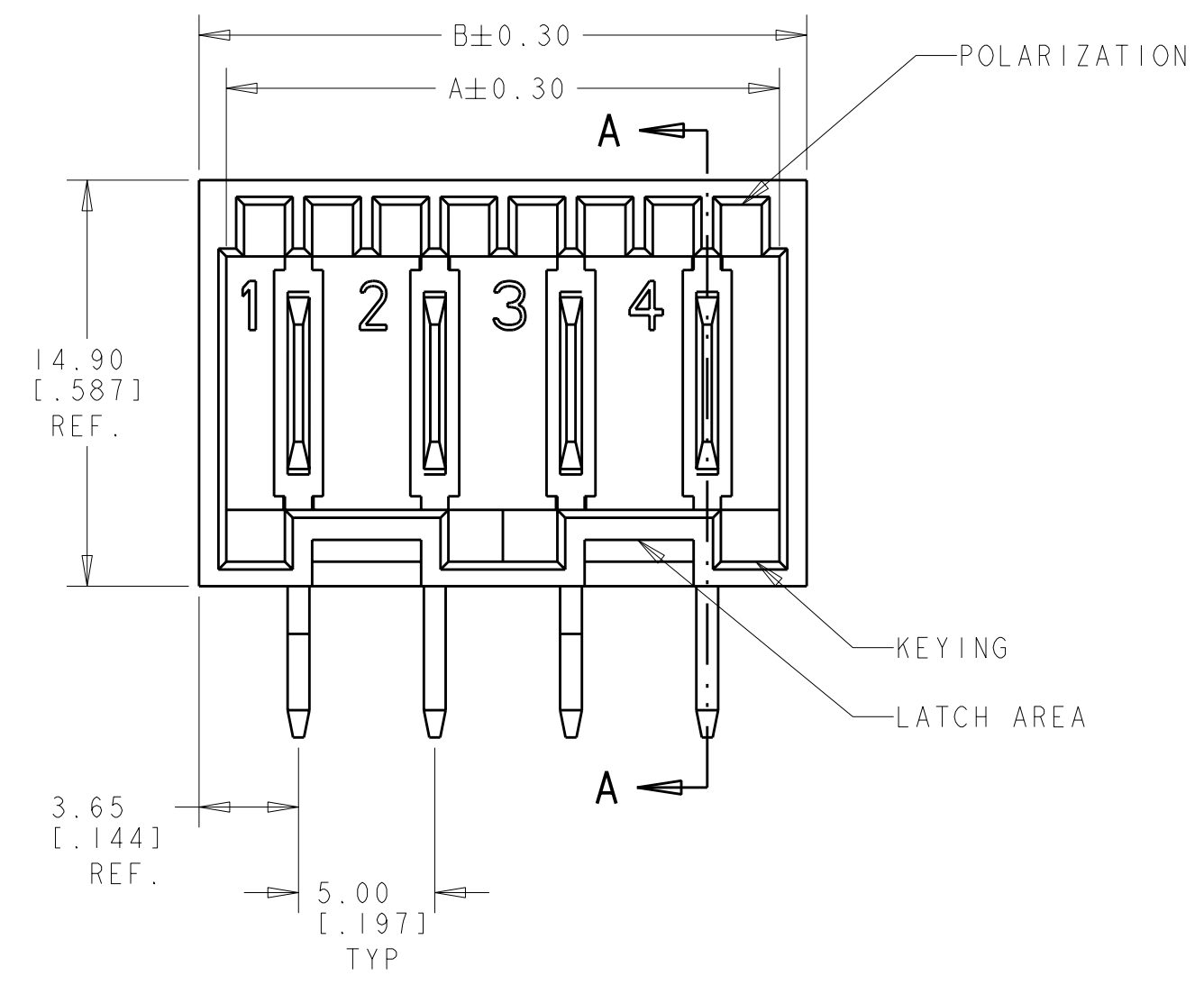
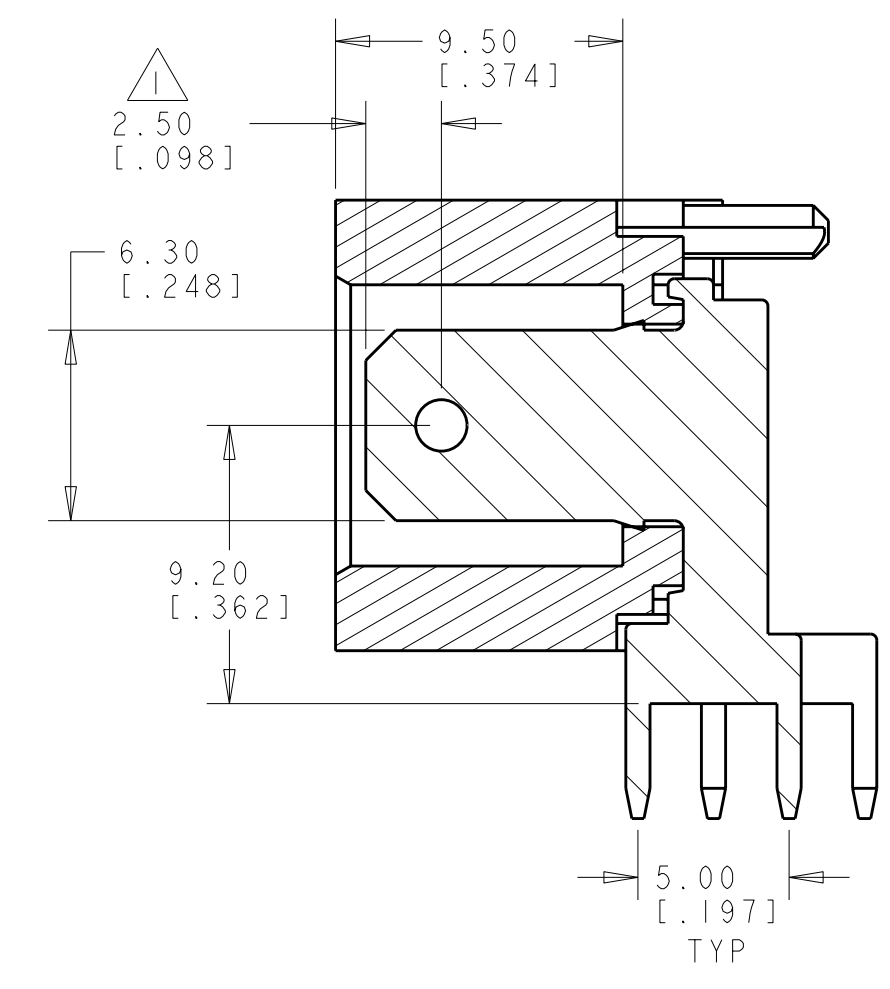
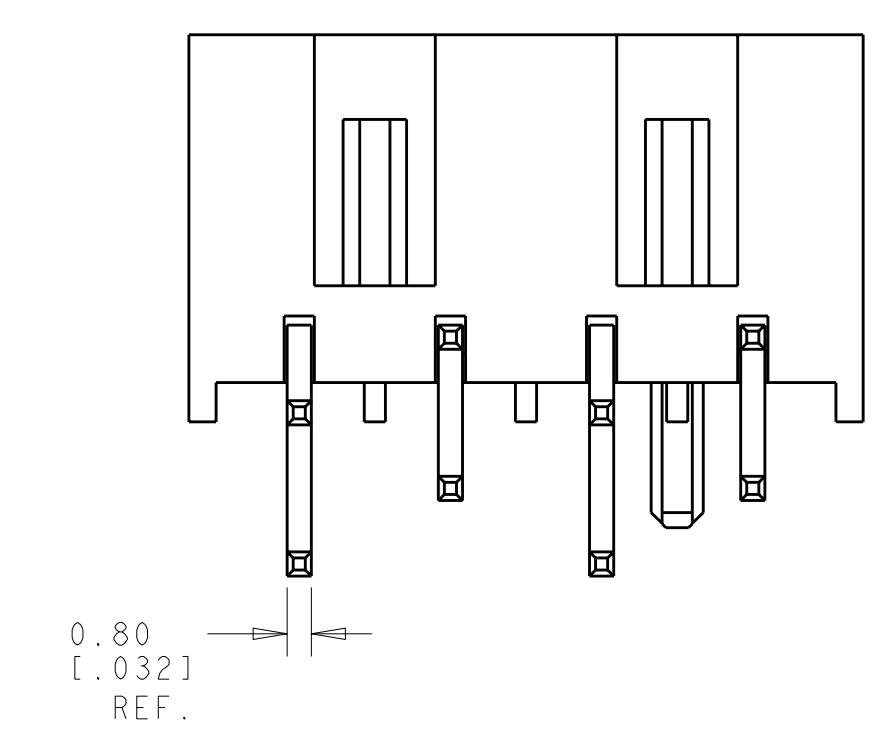

SECTION A-A  
SCALE 4:1

47.3	45.3	9
42.3	40.3	8
37.3	35.3	7
32.3	30.3	6
27.3	25.3	5
22.3	20.3	4
17.3	15.3	3
12.3	10.3	2
B	A	NO. OF POS.

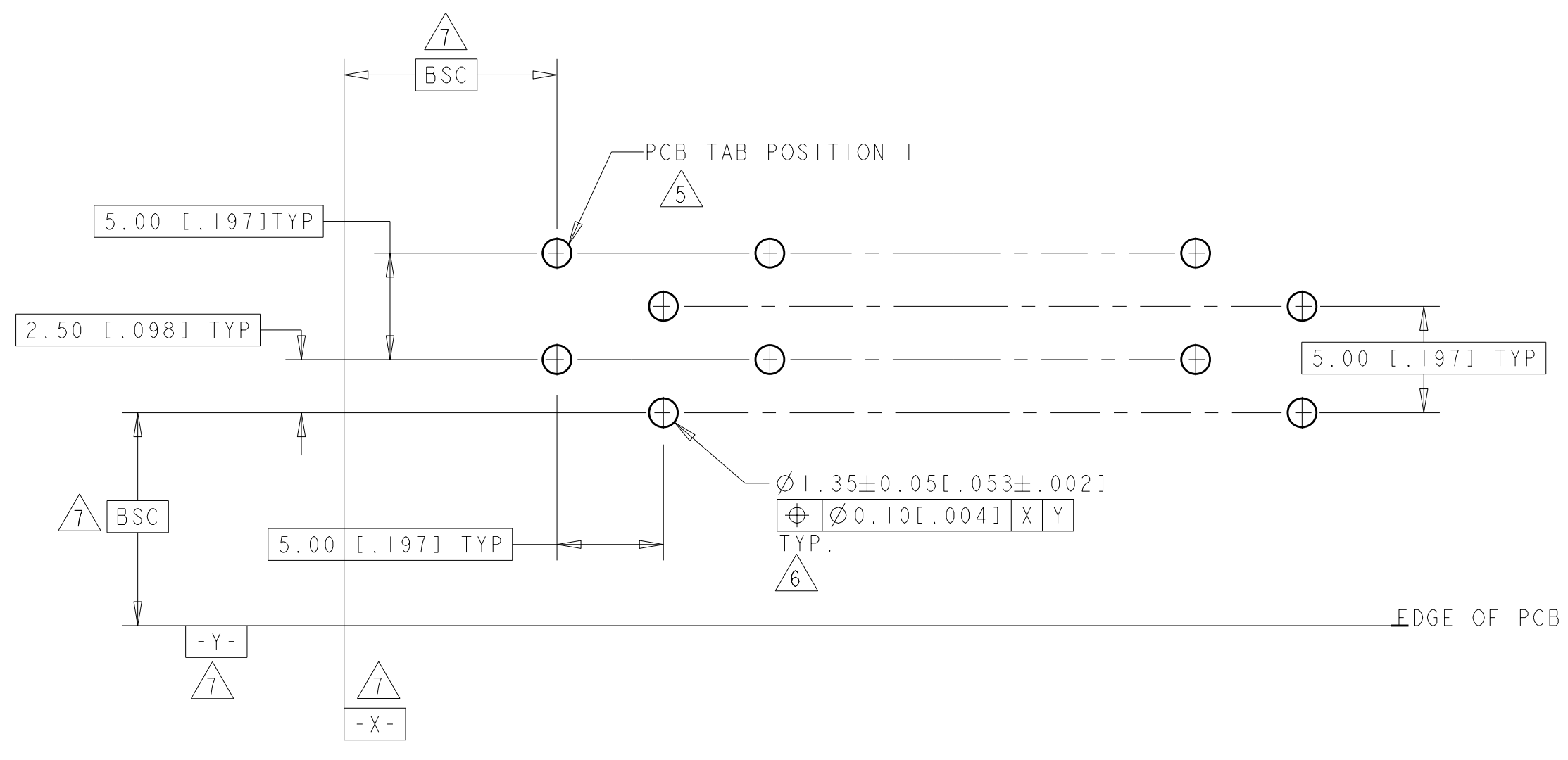

PCB LAYOUT FIG 1 - COMPONENT SIDE  
 PCB 1.5±0.14 [.059±.006] THICK  
 SCALE 4:1

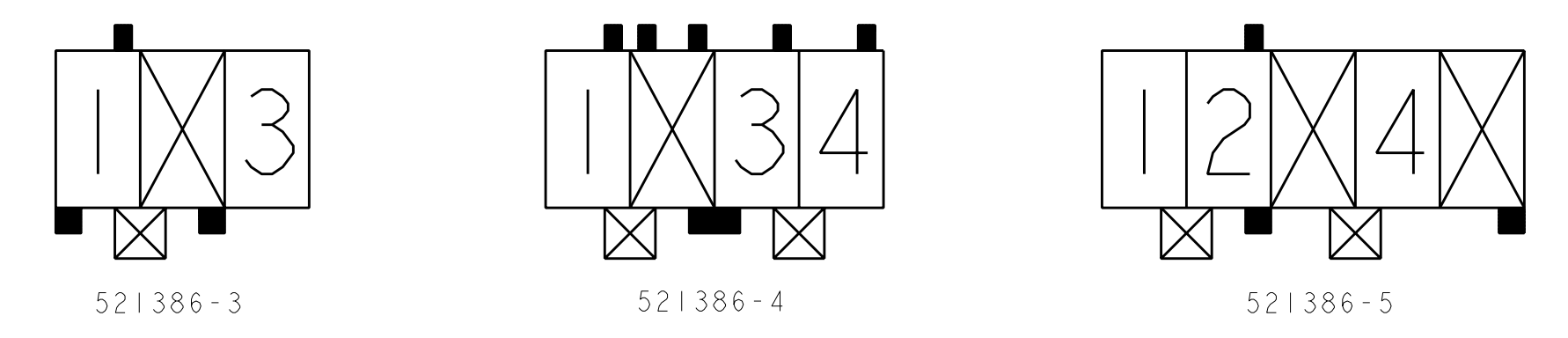

1, 2, 4	1-2, 3-4	2d, 5d	2b	5	-	9	521386-5
1, 3, 4	1-2, 3-4	2d, 3c	1b, 2a, 2b, 3b, 4b	4	-	9	521386-4
1, 3	1-2	1c, 2d	1b	3	03-A	9	521386-3
LOADED TAB POSITIONS	LATCH WINDOWS	KEYING	POLAR.	NO. OF POS.	RAST 5 DESIG.		NEW PART NUMBER

DIMENSIONS: INCHES(mm) 		TOLERANCES UNLESS OTHERWISE SPECIFIED: 9 PLC ± 7 PLC ±0.25(.010) 5 PLC ± 4 PLC ± ANGLES ±2°		DWN R FLAIG 22MAR2004 CHK J HUMMEL 22MAR2004 APVD J HUMMEL 22MAR2004		<b>tyco</b> Tyco Electronics Harrisburg, PA 17105-3608	
MATERIAL: 3		FINISH: 4		PRODUCT SPEC: 108-2183 APPLICATION SPEC:		NAME: ASSEMBLY, POSITIVE-LOCK, RAST 5, SPECIAL VERSION, RIGHT ANGLE	
CUSTOMER DRAWING		WEIGHT:		SIZE: A1 00779 C=521386		RESTRICTED TO:	
SCALE: 4:1		SHEET: 1 OF 1		REV: B		DATE: 07JUN2006	