

MFE-SST | Push-pull clamps

Stainless steel



MATERIAL

AISI 304 stainless steel.

RIVETS

AISI 304 stainless steel.

PUSH LEVER

AISI 304 stainless steel.

REFERENCE BUSHING

AISI 303 stainless steel.

NUT

AISI 304 stainless steel.

BUSHING FIXING SCREWS

AISI 303 stainless steel.

HANDLE

Polyurethane, red colour.

FIXING SQUARE

AISI 304 stainless steel (to be ordered separately).

CLAMPING BOLTS

To be ordered separately.

FEATURES AND APPLICATIONS

All articulated joints are lubricated with special grease.

Thanks to the front outer thread, MFE. clamps can be mounted in a way that the control lever is conveniently positioned using fixing squares (to be ordered separately), or frontally directly on the equipment. Both push and pull clamping can be performed effectively.

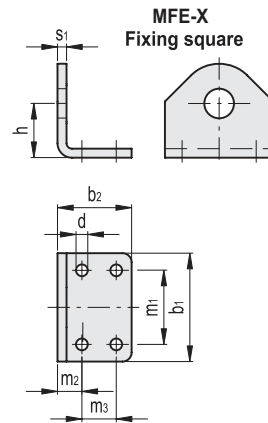
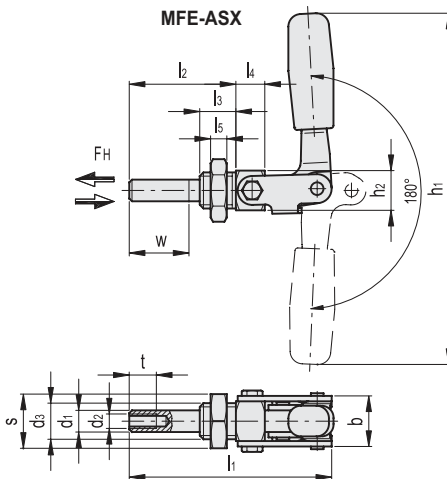
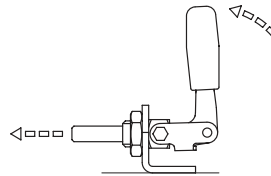

MFE-ASX



Code	Description	b	d1	d2	d3	h1	h2	l1	l2	l3	l4	l5	s	t	Stroke w	FH [N]*	
GG.AS401	MFE.80-ASX	24	10	M6	M16x1.5	120	19	71	38	15.5	10	8	24	12	21	3000	135
GG.AS406	MFE.165-ASX	28	12	M8	M20x1.5	194	22	113	59	20	16	9	30	15	38	5400	335
GG.AS411	MFE.340-ASX	38	16	M10	M24x2	256	30	173	90	22	28	10	36	18	66	7000	835

MFE-X



Code	Description	b1	b2	d	h	m1	m2	m3	s1	For MFE
GG.AS416	MFE.30080X	35	22	5.5	24	20	12	-	4	MFE.80-ASX
GG.AS421	MFE.30165X	60	41	6.5	32	41	13.5	19	5	MFE.165-ASX
GG.AS426	MFE.30340X	75	59	8.5	48	55	19	25	5	MFE.340-ASX

* Holding force.



Models all rights reserved in accordance with the law. Always mention the source when reproducing our drawings and photos.



Toggle clamps

