

REVISIONS					
P	LTR	DESCRIPTION	DATE	DMN	APVD
K		REVISED PER ECO-18-000439	19JAN2018	RS	MZ
L		REVISED PER ECO-20-002046	17FEB2020	RK	MZ

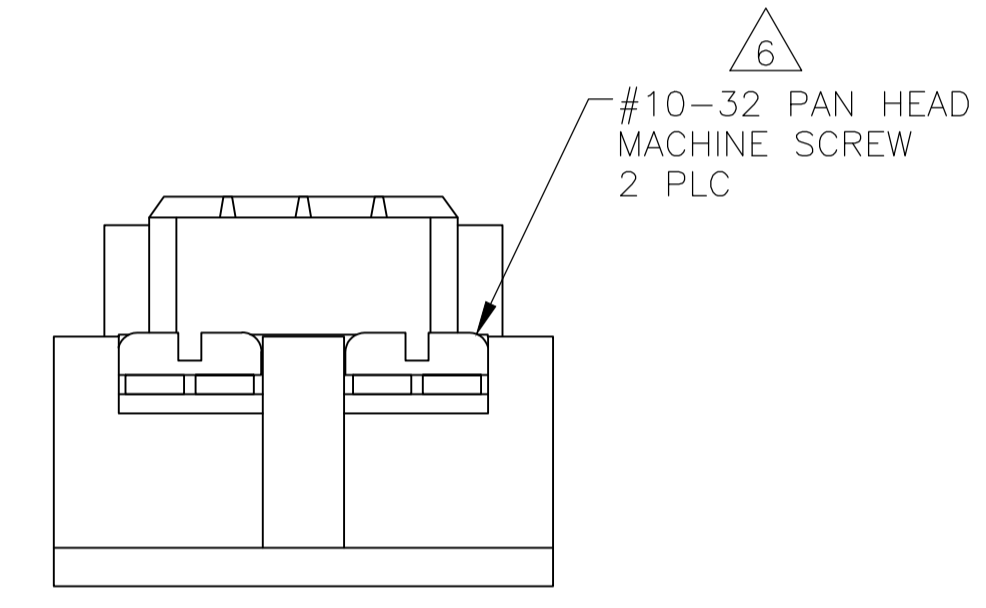
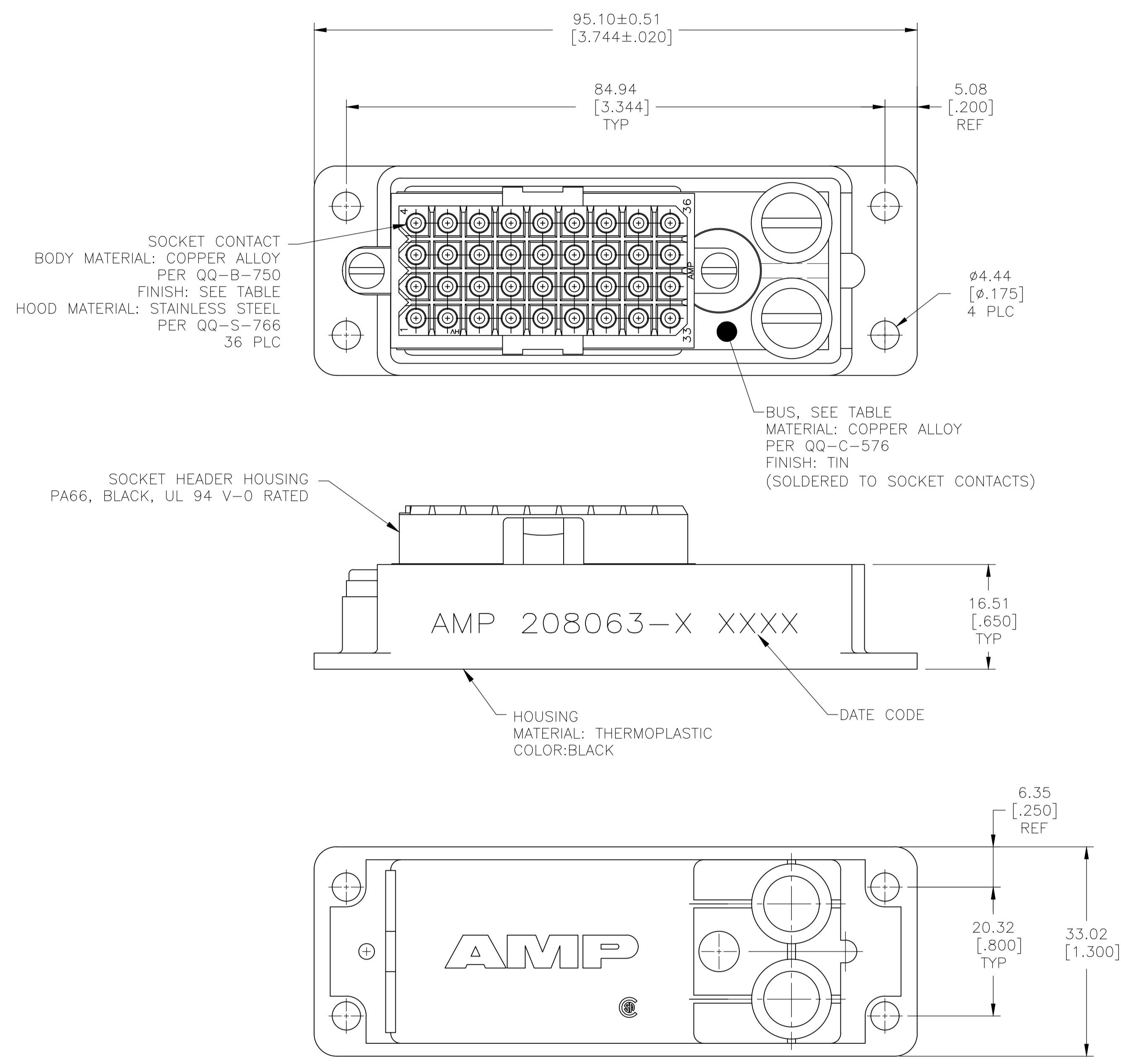

- 1 MATES WITH RECEPTACLE 207020-1.
- △ TIN-LEAD OVER NICKEL PER QQ-N-290.
- △ GOLD FLASH PER MIL-G-45204 OVER 1.27µm [.000050] MIN NICKEL PER QQ-N-290 ON ENTIRE CONTACT, WITH 0.76µm [.000030] MIN GOLD PER MIL-G-45204 ON ELECTRICAL ENGAGEMENT AREA ONLY.
- △ ALL CIRCUITS COMMONED TO BUS.
- △ CONNECTOR IS DIVIDED LENGTHWISE WITH CIRCUITS 1, 2, 5, 6, 9, 10, 13, 14, 17, 18, 21, 22, 25, 26, 29, 30, 33 AND 34 COMMONED, AND CIRCUITS 3, 4, 7, 8, 11, 12, 15, 16, 19, 20, 23, 24, 27, 28, 31, 32, 35 AND 36 COMMONED.
- △ WILL ACCEPT RING TONGUE TERMINALS, STUD SIZE 10.
- △ TIN OVER NICKEL PER QQ-N-290.
- △ OBSOLETE PARTS: OBSOLETE CIS STREAMLINING PER D.RENAUD/D.SINISI

△ OBSOLETE	DUAL, 18 POSITION	△ 5	△ 7	△ 3	208063-7
	DUAL, 18 POSITION	△ 5	△ 7	△ 7	208063-6
	FULL, 36 POSITION	△ 4	△ 7	△ 7	208063-5
△ OBSOLETE	DUAL, 18 POSITION	△ 5	△ 2	△ 3	208063-4
△ OBSOLETE	FULL, 36 POSITION	△ 4	△ 2	△ 3	208063-3
△ OBSOLETE	DUAL, 18 POSITION	△ 5	△ 2	△ 2	208063-2
△ OBSOLETE	FULL, 36 POSITION	△ 4	△ 2	△ 2	208063-1
	BUS TYPE	TAIL FINISH	POST FINISH	PART NO	

THIS DRAWING IS A CONTROLLED DOCUMENT.

DIMENSIONS: mm [INCHES]	TOLERANCES UNLESS OTHERWISE SPECIFIED: 0 PLC ± - 1 PLC ± - 2 PLC ± 0.25 [.010] 3 PLC ± - 4 PLC ± - ANGLES ± -	DIN D.GELTZ 08/06/92 CIK J.McCLINTON 8-27-92 APVD A. TRAVIS 8-27-92	NAME COMMONING DEVICE ASSEMBLY, 36 POSITION, METRIMATE
MATERIAL SEE CALLOUTS	FINISH SEE CALLOUTS	WEIGHT -	SIZE A1
CUSTOMER DRAWING		SCALE 2:1	SHEET 1 OF 1

RESTRICTED TO