

The BLC series isolated-type DC-DC converters feature a small package (23.2x21.1x9.7mm) and light weight (5.4g) capable of 6W output.

As ultralow noise and extremely high efficiency are made possible by a new circuit, it is ideal for an analog circuit as well as an analog and digital hybrid circuit.

#### ■ Features

- Ultra low noise
- Adjustable Output Voltage
- ON/OFF Control
- Dual power supply usable as single power supply
- Withstand voltage AC500V
- Over Current Protection Circuit
- No tantalum capacitor or electrolytic capacitor
- Covered with a metal shield
- Surface Mount Package
- No heat sink needed
- Operating Temp Range -40°C to +85°C (Temperature derating required)
- RoHS Compliant

#### ■ Model/Rating

Table 1

Models BLC Series	Input V Vdc	Output V Vdc	Output I mA	Line Reg. mV(max.)	Load Reg. mV(max.)	Ripple Noise mVpp(typ.)	Efficiency %(typ.)
<b>BLC12-05S120</b>	9 to 18	5	0 to 1200	20	40	8	80
<b>BLC12-12S50</b>		12(15)	0 to 500(400)	40	100	8	83
<b>BLC12-12W25</b>		±12(±15)	0 to 250(200)	80	600	8	83

Note 1: Output voltage in parentheses is when Vadj and -Vout are short-circuited.

Note 2: Output current in parentheses is at the maximum output voltage.

Note 3: Ripple noise and efficiency are at 12V input voltage and load rating.

Note 4: Ripple noise is measured at 20MHz bandwidth, with a multi layered ceramic capacitor with 10μF at input and 0.47μF at output

#### ■ Specifications

Table 2

Input voltage range	Refer to Table 1
Rated output voltage	5.0V±3%, 12V±3% , ±12V±5% (When Vadj terminal is open)
Adjustable output voltage range	4.75 to 6.0V (5.0V model), 11.4 to 15V (12V model), ±11.4 to ±15V (±12V model)
Line regulation	Refer to Table 1 (Rated output, Input voltage varying in the range of Table 1)
Load regulation	Refer to Table 1 (Rated input/output, Load varying from 0 to 100%, ±output is upon loaded evenly)
Temperature regulation	40mV typ.(5.0V model), 100mV typ. (12V model), 150mV typ. (±12V model) (Rated input/output, for within ambient temperature range with 100% load at temperature derating)
Ripple noise	Refer to Table 1 (Rated input/output, common temp, measurement frequency bandwidth 20MHz)
Efficiency	80% to 83% typ. (Rated input/output, Common temp., Refer to Table 1)
Over current protection	Operate at 105% or above of rated load current. Auto restart type.
Over voltage protection	None
Under Voltage Lock Out	Yes (Refer page 9)
Input over current protection	Input circuit has a built-in fuse (Refer page 9)
Remote ON/OFF control	Between 2Pin (-Vin) and 3Pin (ON/OFF): Output is ON when open, output is OFF when short.
Standby current	4mA max.
Withstand voltage	Between input and output, input and case, output and case: AC500V/per minute.
Insulation resistance	Between input and output, input and case, output and case: 50MΩ or more (at DC500V)
Capacitance between P and S	Approx. 40 to 90pF (depending on the model)
Operating temp range	Operating temperatures -40°C to +85°C (Refer to temp derating of page4)
Storage temp range	Storage temperatures -40°C to +85°C
Humidity range	20 to 95%R.H. (Max. wet bulb temp 35°C with no condensation)
Storage conditions	Below 30°C/60% R.H. before mounting the converter
Cooling conditions	Natural cooling (install in a well-ventilated place)
Vibration	10 to 55Hz Total amplitude 1.52mmp-p (2H for each of three directions) Sweep time 15 min
Impact	Acceleration 100G (3 times for each of three directions, total 18 times) Duration 6ms
Weight	5.4g typ.
Outer dimensions	W=23.2 L=21.1 H=9.7 typ.(mm)(For dimensional details, refer to the shape and dimensions in the datasheet)

\* The above specifications are provided with rated input/output and ambient temperature 25°C±5°C, unless otherwise specified.

\* The contents provided in this datasheet may be changed at any time without prior notice.

## 1. Scope

These specifications shall apply to the DC input, isolated type DC-DC converter BLC12 series.

## 2. Model/Rating

Model name	Rated input voltage	Rated output	Shape	Remarks
BLC12-05S120	DC12.0V	5.0V,1200mA	SMD	
BLC12-12S50		12.0V,500mA		
BLC12-12W25		±12V, each 250mA		

Unless otherwise mentioned in these specifications, input shall be rated input, output shall be rated output, and ambient temperature shall be 25°C±5°C.

## 3. Environmental conditions

## 3-1 Temperature range

In operation -40°C to +85°C (Derating required)

In storage -40°C to +85°C

## 3-2 Humidity range

In operation 20 to 95%R.H. (However, max. wet bulb temperature 35°C, no condensation)

In storage 20 to 95%R.H. (However, max. wet bulb temperature 35°C, no condensation)

Note) Store in a place below 30°C and 60% R.H. before mounting.

## 4. Specifications &amp; Standards

This product complies with RoHS Directive and Bellnix Environmental Management Regulations.

## 4-1 Input conditions and output characteristics

\*1

Model name	Input voltage V	Output voltage V	Output current mA	Output voltage stability <sup>*2</sup>			Output ripple noise <sup>*3</sup> mVp-p typ. / max	Efficiency % typ.
				Input mV max.	Load mV max.	Temp. mV max.		
BLC12-05S120	9.0 to 18.0	5±3%	0 to 1200	20	40	40	8/ 20	80
BLC12-12S50	9.0 to 18.0	12±3%	0 to 500	40	100	100	8/ 20	83
BLC12-12W25	9.0 to 18.0	±12±5%	0 to 250×2	80	600	150	8/ 20	83

\*1 With the measurement circuit of 4-4. Unless otherwise mentioned, input and output values are rated and ambient temperature shall be 25°C±5°C.

\*2 Input: Input voltage varying from min. to max.

Load: Output current varying from 0 to rated.

Temperature: Ambient temperatures varying from -40 to T<sub>max</sub>.

Within ambient temperature range with 100% load at temperature derating of 4-3.

A two output product is when + output current and – output current are equal.

\*3 Frequency bandwidth 20MHz measured at both ends of external capacitor (C2, or C4, C5).

## 4-2 Capacitance of external capacitor

This product has a limited capacitance for output external capacitors. Limit the capacitance of an external capacitor as follows:

External output capacitor

Model name	Capacitance	
	Plus output side	Minus output side
BLC12-05S120	0 to 220μF <sup>*1</sup>	—
BLC12-12S50	0 to 100μF <sup>*1</sup>	—
BLC12-12W25	0 to 100μF <sup>*2</sup>	0 to 100μF <sup>*3</sup>

\*1 Total of C2 and C3 in the Standard Connection Circuit of 6-1

\*2 Total of C2 and C4 in the Standard Connection Circuit of 6-2

\*3 Total of C3 and C5 in the Standard Connection Circuit of 6-2

4-3 Temperature derating

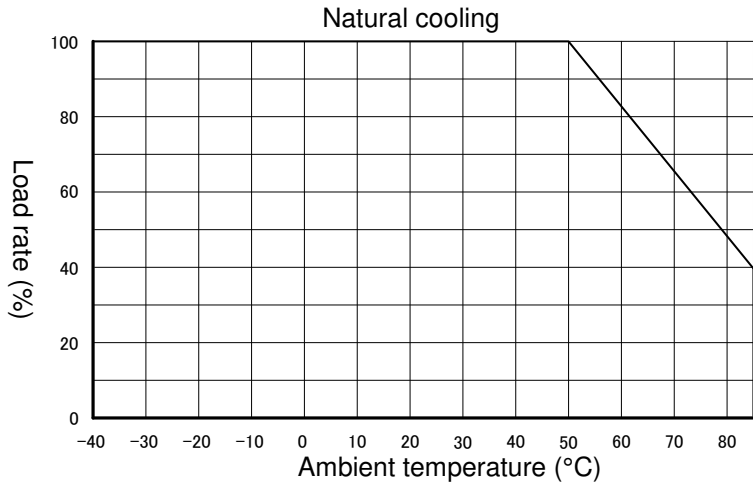

Note) at rated output

4-4 Measurement circuit

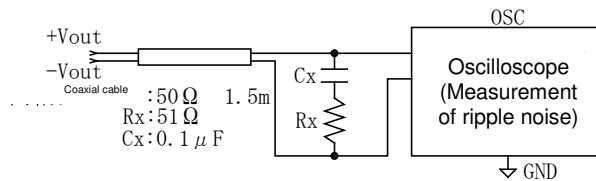
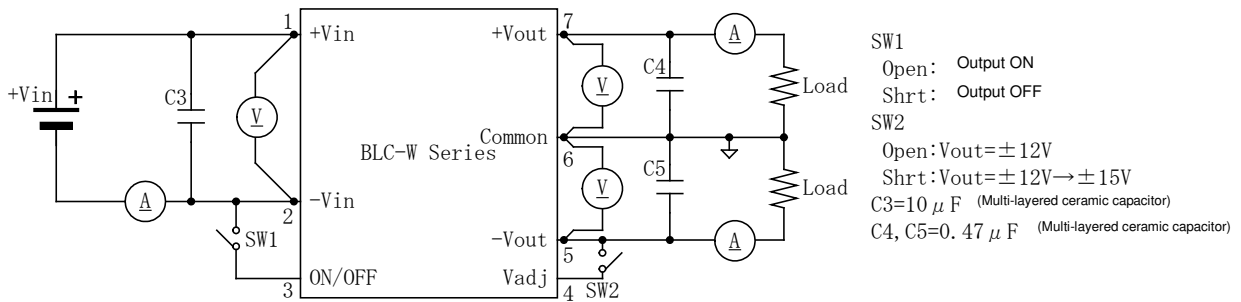
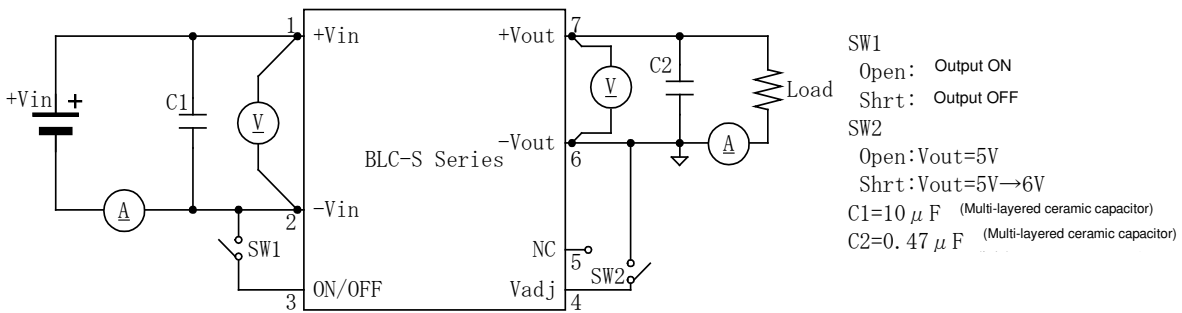

4-5 Additional functions

Item	Specifications & Standards	Conditions
Over current protection circuit	Operate at 105% or above, auto restart type	
Over voltage protection circuit	None	
Adjustable output voltage range	4.75 to 6.0V (BLC12-05S120) 11.4 to 15V (BLC12-12S50) ±11.4 to ±15V (BLC12-12W25)	By external resistor Refer to 7-3
ON/OFF control	Output is ON when OPEN Low (0 to 0.5V, 4mA max.) for output OFF	Refer to 7-1

4-6 Withstand voltage and Insulation resistance

- 1) Withstand voltage  
Between input and output, input and case, output and case: AC500V/per min
- 2) Insulation resistance  
Between input and output, input and case, output and case: 50MΩ or more (at DC500V)

5. Outer dimensions and description of terminals

5-1 Shape and dimensions

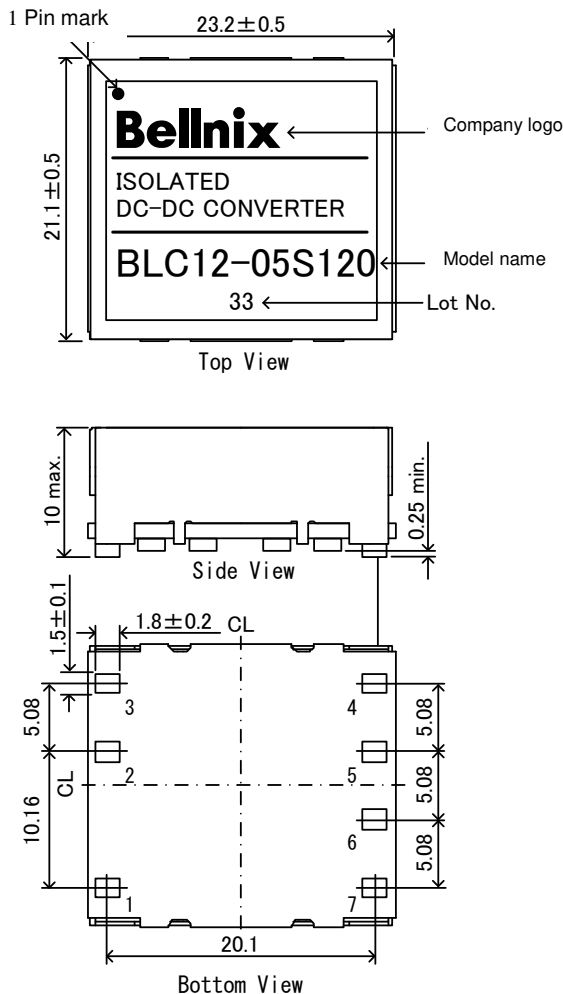

Pin	Function	
	BLC-S	BLC-W
1	+Vin	+Vin
2	-Vin	-Vin
3	ON/OFF	ON/OFF
4	Vadj	Vadj
5	NC	-Vout
6	-Vout	Common
7	+Vout	+Vout

Materials of terminals and case

Terminal pin----- Material: Copper  
Plating: Gold plating after nickel plating  
Case ----- Material: Nickel silver

- Unit: mm
- Dimensional tolerance (unless specified): ±0.3
- Weight: 5.4g typ.
- Tolerance on terminals 0.2 mm max. (Max. lifting of the terminal part when placed on a plane)

5-2 Recommended footprint dimensions

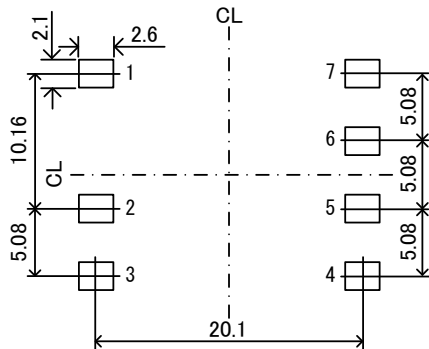

Note) Recommended dimensions are shown above. Use your design standard for your specific design.

5-3 Lot indication

3 1 (Manufactured in January 2013)

3 D 2 (Manufactured in December 2013)

Production code for manufacturing control (may not be indicated)

Manufacturing month (Jan to Sep = 1 to 9, Oct = O, Nov = N, Dec = D)

Manufacturing year (the last digit of A.D.)

6. Standard connection circuit

6-1 BLC-S series

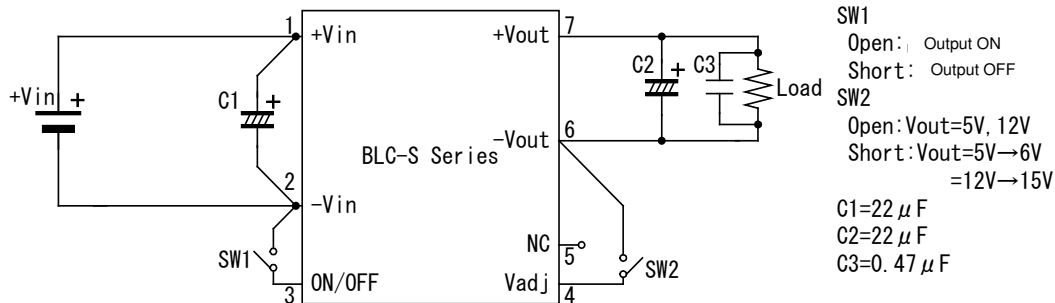

6-2 BLC-W series

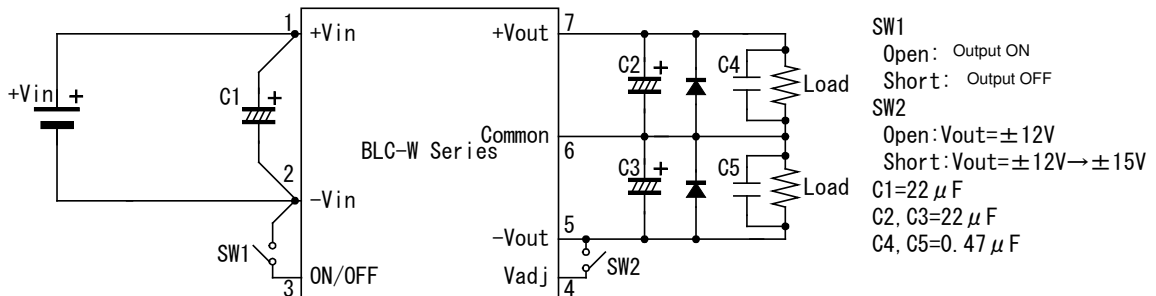

## 7. Various functions

## 7-1 ON/OFF control

The ON/OFF control function enables users to control ON/OFF of the output voltage without inputting or cutting it off.

Between  $-V_{in}$  terminal (No. 2 pin) and ON/OFF terminal (No. 3 pin)  
 Open (6V max.) : Output ON  
 Short (0 to 0.5V, 4mA max.) : Output OFF

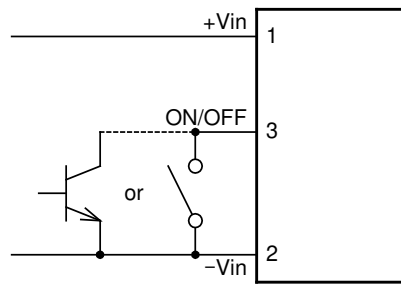

## 7-2 Output over current protection

If output current has reached over current status, the over current protection circuit is activated lowering the output voltage. (Activating point: 105% or above of the rated load current)

The converter should automatically returns to normal operation as soon as the over current status is resolved, if this does not occur, turn off the power or turn the output OFF with an ON/OFF control and then reactivate.

Holding of over current status for over 30 seconds may result in damage, so resolve over current status within 30 seconds.

Characteristics in the over current mode

## 7-3

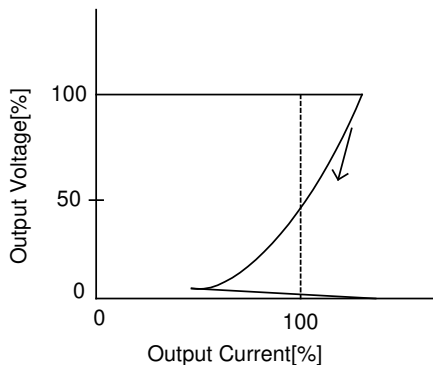

Note) A drooping characteristic may be seen in the over current protection state as shown on the left figure. Note that output voltage may not go up if connected to a nonlinear load such as a lamp, motor, etc., or a constant current load.

Adjustable Output voltage

7-3-1 Short circuiting Vadj and -Vout terminals

Output voltage can be set at the maximum as per the following table by short-circuiting Vadj and -Vout terminals. In case of no variable output voltage, open the terminal.

Output voltage for the connection of Vadj terminal

Model name	Between Vadj and -Vout terminals	
	Open	Short
BLC12-05S120	5.0V	6.0V
BLC12-12S50	12.0V	15.0V
BLC12-12W25	±12.0V	±15.0V

7-3-2 Resistor adjustment control

The output voltage is adjustable by inserting a resistor between Vadj terminal and +Vout terminal or -Vout terminal.

To decrease the output voltage

To increase the output voltage

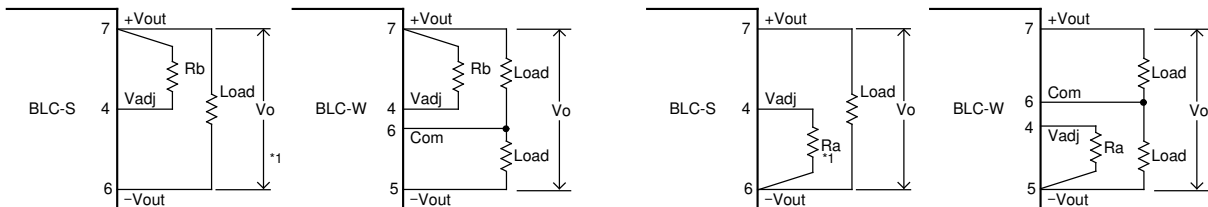

Model name	To decrease the output voltage Output voltage: Vo[V], Connecting resistor: Rb[kΩ]	To increase the output voltage Output voltage: Vo[V], Connecting resistor: Ra[kΩ]
BLC12-05S120	$Vo = (49.94Rb + 1448.94) / (340.56 + 10Rb)$ $Rb = (340.56Vo - 1448.94) / (49.94 - 10Vo)$ Variable range: Vo=4.75V min.	$Vo = (1448.94 + 49.94Ra) / (10Ra + 240)$ $Ra = (1448.94 - 240Vo) / (10Vo - 49.94)$ Variable range: Vo=6.0V max.
BLC12-12S50	$Vo = (17.98Rb + 105.86) / (15.63 + 1.5Rb)$ $Rb = (15.63Vo - 105.86) / (17.98 - 1.5Vo)$ Variable range: Vo=11.4V min.	$Vo = (105.86 + 17.98Ra) / (1.5Ra + 7.05)$ $Ra = (105.86 - 7.05Vo) / (1.5Vo - 17.98)$ Variable range: Vo=15.0V max.
BLC12-12W25	$Vo = (53.04Rb + 539.53) / (60.06 + 2.2Rb)$ $Rb = (60.06Vo - 539.53) / (53.04 - 2.2Vo)$ Variable range: Vo=22.8V min. (±11.4V min.)	$Vo = (539.53 + 53.04Ra) / (2.2Ra + 18.04)$ $Ra = (539.53 - 18.04Vo) / (2.2Vo - 53.04)$ Variable range: Vo=30.0V max. (±15.0V max.)

Note) If output voltage is made variable, use at the maximum power or less.

If output voltage is made lower, do not connect Rb to resistor which is less than Vo min. setting resistor value.



7-4 Activation and deactivation voltage

This product has an under voltage lock out function to prevent malfunction when there is low input voltage. The activation voltage and deactivation voltage is within the range shown in the table below.

Range of activation and deactivation voltage	7.0 to 8.6V
--	-------------

7-5 Input circuit protection function

This input circuit has a built-in fuse to protect the secondary circuit against over current that runs for any reason.

Rated current and fusing current of the built-in fuse are as shown in the following table. Power supply should have more current capacity than the following fusing current to ensure a fuse blowout in an emergency.

Rated current	2.5A
Fusing current	5A or more

8. Protection against reverse connection of input power supply (example)

This product may be damaged if erroneously connected with reverse input polarity. To cope with a possible reverse connection, add a protection circuit as shown in the following figure. The following is an example using a fuse and a diode.

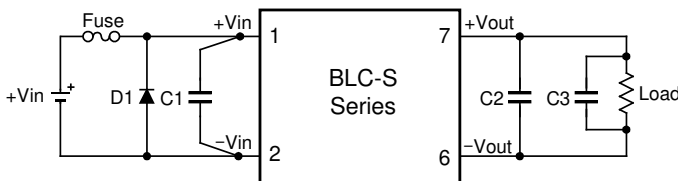

9. Common mode noise reduction method (example)

To reduce common mode noise of this product, connect a capacitor of 1000pF or so (C4) between the primary and secondary terminals as shown in the following figure. In this case, note that using a capacitor of too much capacitance may result in the increase of coupling capacitance between primary and secondary terminals. Also, select a capacitor in consideration of required withstand voltage. (Noise on the primary side may run through to the secondary side through C4 according to conditions, so check in actual use conditions.)

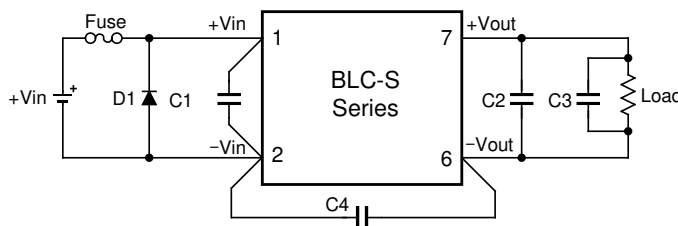

10. Input feedback noise reduction method (example)

Input feedback noise from the convertor can be reduced by designing a Pi filter at input side as shown in the following figure. Add as needed.

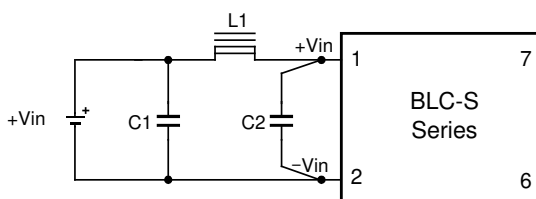

11. Serial operation method (example)

Serial operation is possible by wiring this product as per the following figure. Limit the output current not to exceed the smaller rated current of the power supplies connected in series to avoid more current than rating to run into the power supply.

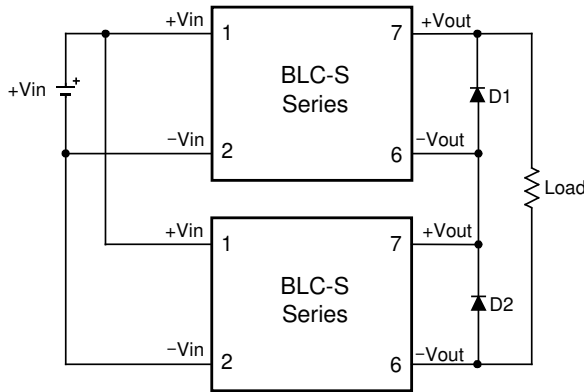

Note) This product is not suitable for parallel operation.  
Schottky diodes of low forward voltage are recommended for D1 and D2.

12. Soldering conditions

Observe the following conditions for soldering temperature and time. Flow mounting is not possible for this product.

Reflow method

Reflow temperature profile  
In the case of Sn-3Ag-0.5Cu series solder

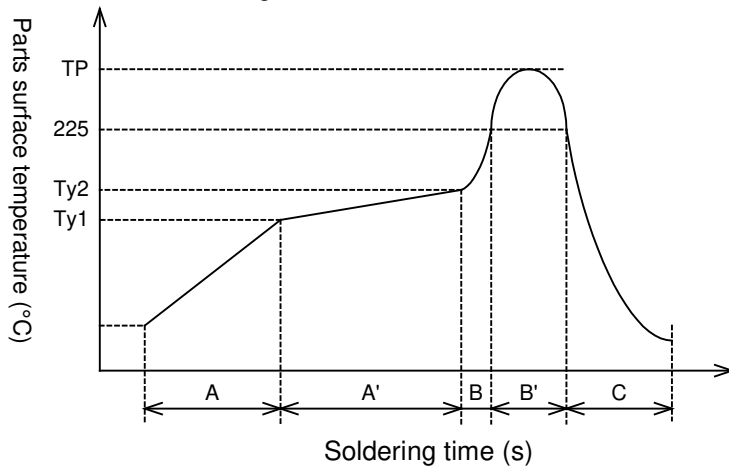

A	1.0 ~ 3.0°C/s	
A'	Ty1:	150±10°C
	Ty2:	170±10°C
	Ty1 ~ Ty2:	40 ~ 100s
B	1.0 ~ 4.0°C/s	
B'	TP:	245°Cmax.
	225°C and over	20 ~ 40s
C	1.0 ~ 5.0°C/s	

Refrain from causing vibration of the product during the reflow.  
The number of reflows shall be once (no mounting of the reverse side).  
\* Eutectic solder may be used so far as within the above profile condition.

### 13. Vibration and impact tests

Vibration 10 to 55Hz Total amplitude 1.52mmp-p (2H for each of three directions)

Sweep time 15 minutes

Impact Acceleration 100G (3 times for each of 6 directions, total 18 times)

Impact time 6ms

### 14. Cleaning

This product is not for immersible cleaning. Use of no-clean flux is recommended.

### 15. Precautions for use

To ensure user's safety, check specifications before using the product and always observe the following precautions for use.

- This product is intended for use in general electronics equipment (office equipment, communication equipment, measurement equipment). Do not use the product for medical equipment, nuclear equipment, trains, etc., whereby human life or property may be directly affected by damaged product. Consult with us for any use other than for such general electronics equipment.
- Minor changes and component parts changes that do not affect contents of the specifications will be made due to characteristic improvement of the product and other reasons without prior notice.
- This product is not suitable for parallel operation.
- Do not use connectors and sockets for mounting the product. Contact resistance may have an adverse effect on the performance. Use the soldering method for mounting on the printed circuit board.
- This equipment has a built-in over current protection circuit but avoid a prolonged short circuit which may lead to failure.
- This product may be damaged if used under nonstandard electrical conditions or nonstandard environmental conditions including temperature. Ensure use within the standards.
- Avoid using this product in a place that generates corrosive gas or is dusty.
- This product may be damaged by static electricity. Make sure that the workplace is guarded against static buildup and static electricity on operators by use of proper grounding.
- This product has no built-in function for over voltage protection.
- This product does not come with a test report.

### 16. Warranty

The warranty term of the product is one year after shipment. Should the product become defective within the warranty period due to our design or workmanship, the product will be repaired free of charge or replaced. However, this warranty does not cover products which have been subjected to unauthorized inner modifications, etc.

The scope of our warranty is limited to that of the said product.

### 17. Contact

If you have any further technical questions for this product, please contact us.

E-mail: [info@bellnix.com](mailto:info@bellnix.com)

URL: <http://www.bellnix.com>