

Introduction

The Atmel® | SMART™ SAM C20 is a series of microcontrollers optimized for industrial automation, appliances and other 5V applications using the 32-bit ARM® Cortex®-M0+ processor, ranging from 32- to 64-pins with up to 256KB Flash and 32KB of SRAM and operate at a maximum frequency of 48MHz and reach 2.46 CoreMark®/MHz. The SAM C20 devices are designed for simple and intuitive migration with identical peripheral modules, hex compatible code, identical linear address map and pin compatible migration paths between all devices in the product series. All devices include intelligent and flexible peripherals, Atmel Event System for inter-peripheral signaling, and support for capacitive touch button, slider and wheel user interfaces.

SAM C20 devices are pin compatible to the SAM D and SAM C family of general purpose microcontrollers.

Features

- Processor
 - ARM Cortex-M0+ CPU running at up to 48MHz
 - Single-cycle hardware multiplier
 - Micro Trace Buffer
 - Memory Protection Unit (MPU)
- Memories
 - 32/64/128/256KB in-system self-programmable Flash
 - 1/2/4/8KB independent self-programmable Flash for EEPROM emulation
 - 4/8/16/32KB SRAM Main Memory
- System
 - Power-on reset (POR) and brown-out detection (BOD)
 - Internal and external clock options with 48MHz to 96MHz Fractional Digital Phase Locked Loop (FDPLL96M)
 - External Interrupt Controller (EIC)
 - 16 external interrupts
 - One non-maskable interrupt

- Two-pin Serial Wire Debug (SWD) programming, test and debugging interface
- Low Power
 - Idle, standby, and off sleep modes
 - SleepWalking peripherals
- Peripherals
 - Hardware Divide and Square Root Accelerator (DIVAS)
 - 6-channel Direct Memory Access Controller (DMAC)
 - 6-channel Event System
 - Up to five 16-bit Timer/Counters (TC), configurable as either:
 - One 16-bit TC with compare/capture channels
 - One 8-bit TC with compare/capture channels
 - One 32-bit TC with compare/capture channels, by using two TCs
 - One 24-bit Timer/Counter for Control (TCC), with extended functions:
 - Up to four compare channels with optional complementary output
 - Generation of synchronized pulse width modulation (PWM) pattern across port pins
 - Deterministic fault protection, fast decay and configurable dead-time between complementary output
 - Dithering that increase resolution with up to 5 bit and reduce quantization error
 - Frequency Meter
 - 32-bit Real Time Counter (RTC) with clock/calendar function
 - Watchdog Timer (WDT)
 - CRC-32 generator
 - Up to four Serial Communication Interfaces (SERCOM), each configurable to operate as either:
 - USART with full-duplex and single-wire half-duplex configuration
 - I²C up to 3.4MHz
 - SPI
 - LIN master/slave
 - RS-485
 - One Configurable Custom Logic (CCL)
 - One 12-bit, 1Msps Analog-to-Digital Converter (ADC) with up to 12 channels
 - Differential and single-ended input
 - Automatic offset and gain error compensation
 - Oversampling and decimation in hardware to support 13-, 14-, 15- or 16-bit resolution
 - Two Analog Comparators (AC) with window compare function
 - Peripheral Touch Controller (PTC)
 - 256-Channel capacitive touch and proximity sensing
- I/O
 - Up to 52 programmable I/O pins
- Drop in compatible with SAM D20 and SAM D21
- Packages
 - 64-pin TQFP, QFN
 - 56-pin WLCSP
 - 48-pin TQFP, QFN

- 32-pin TQFP, QFN
- Operating Voltage
 - 2.7V – 5.5V

Table of Contents

Introduction.....	1
Features.....	1
1. Description.....	5
2. Configuration Summary.....	6
3. Ordering Information.....	8
3.1. SAM C20E.....	8
3.2. SAM C20G.....	9
3.3. SAM C20J.....	10
3.4. Device Identification.....	11
4. Block Diagram.....	13
5. Pinout.....	15
5.1. SAM C20E.....	15
5.2. SAM C20G.....	16
5.3. SAM C20J.....	17
6. Signal Descriptions List.....	19
7. I/O Multiplexing and Considerations.....	21
7.1. Multiplexed Signals.....	21
7.2. Other Functions.....	22
8. Product Mapping.....	25
9. Processor and Architecture.....	26
9.1. Cortex M0+ Processor.....	26
9.2. Nested Vector Interrupt Controller.....	27
9.3. Micro Trace Buffer.....	29
9.4. High-Speed Bus System.....	30
10. Packaging Information.....	33
10.1. Thermal Considerations.....	33
10.2. Package Drawings.....	34
10.3. Soldering Profile.....	43

1. Description

The Atmel SAM C20 devices provide the following features: In-system programmable Flash, six-channel direct memory access (DMA) controller, six-channel Event System, programmable interrupt controller, up to 52 programmable I/O pins, 32-bit real-time clock and calendar, up to five 16-bit Timer/Counters (TC) and three Timer/Counters for Control (TCC), where each TC can be configured to perform frequency and waveform generation, accurate program execution timing or input capture with time and frequency measurement of digital signals. The TCs can operate in 8- or 16-bit mode, selected TCs can be cascaded to form a 32-bit TC, and three timer/counters have extended functions optimized for motor, lighting and other control applications. Two TCC can operate in 24-bit mode, and the third TCC can operate in 16-bit mode. The series provide up to four Serial Communication Modules (SERCOM) that each can be configured to act as an USART, UART, SPI, I²C up to 3.4MHz, SMBus, RS-485 and LIN master/slave; one 12-bit, 1Msps ADC with up to 12-channels, two analog comparators with window mode, Peripheral Touch Controller supporting up to 256 buttons, sliders, wheels and proximity sensing; programmable Watchdog Timer, brown-out detector and power-on reset and two-pin Serial Wire Debug (SWD) program and debug interface.

All devices have accurate and low-power external and internal oscillators. All oscillators can be used as a source for the system clock. Different clock domains can be independently configured to run at different frequencies, enabling power saving by running each peripheral at its optimal clock frequency, and thus maintaining a high CPU frequency while reducing power consumption.

The SAM C20 devices have three software-selectable sleep modes, idle, standby and off. In idle mode the CPU is stopped while all other functions can be kept running. In standby all clocks and functions are stopped except those selected to continue running. In this mode all RAMs and logic contents are retained. The device supports SleepWalking. This feature allows the peripheral to wake up from sleep based on predefined conditions, and thus allows some internal operation like DMA transfer and/or the CPU to wake up only when needed, e.g. when a threshold is crossed or a result is ready. The Event System supports synchronous and asynchronous events, allowing peripherals to receive, react to and send events even in standby mode.

The Flash program memory can be reprogrammed in-system through the SWD interface. The same interface can be used for non-intrusive on-chip debug of application code. A boot loader running in the device can use any communication interface to download and upgrade the application program in the Flash memory.

The Atmel SAM C20 devices are supported with a full suite of program and system development tools, including C compilers, macro assemblers, program debugger/simulators, programmers and evaluation kits.

2. Configuration Summary

	SAM C20J	SAM C20G	SAM C20E
Pins	64 (56 for WLCSP)	48	32
General Purpose I/O-pins (GPIOs)	52	38	26
Flash	256/128/64/32KB	256/128/64/32KB	256/128/64/32KB
Flash RWW section	8/4/2/1KB	8/4/2/1KB	8/4/2/1KB
System SRAM	32/16/8/4KB	32/16/8/4KB	32/16/8/4KB
Timer Counter (TC) instances	5	5	5
Waveform output channels per TC instance	2	2	2
Timer Counter for Control (TCC) instances	1	1	1
Waveform output channels per TCC	8	8	6
DMA channels	6	6	6
Configurable Custom Logic (CCL) (LUTs)	4	4	4
Serial Communication Interface (SERCOM) instances	4	4	4
Analog-to-Digital Converter (ADC) channels	12	12	10
Analog Comparators (AC)	2	2	2
Real-Time Counter (RTC)	Yes	Yes	Yes
RTC alarms	1	1	1
RTC compare values	One 32-bit value or two 16-bit values	One 32-bit value or two 16-bit values	One 32-bit value or two 16-bit values
External Interrupt lines	16	16	16
Peripheral Touch Controller (PTC) Number of self-capacitance channels (Y-lines)	32	22	16
Peripheral Touch Controller (PTC) Number of mutual-capacitance channels (X x Y lines)	256 (16x16)	121 (11x11)	64 (8x8)
Maximum CPU frequency	48MHz		
Packages	QFN TQFP WLCSP	QFN TQFP	QFN TQFP

	SAM C20J	SAM C20G	SAM C20E
Oscillators	32.768kHz crystal oscillator (XOSC32K) 0.4-32MHz crystal oscillator (XOSC) 32.768kHz internal oscillator (OSC32K) 32KHz ultra-low-power internal oscillator (OSCULP32K) 48MHz high-accuracy internal oscillator (OSC48M) 96MHz Fractional Digital Phased Locked Loop (FDPLL96M)		
Event System channels	6	6	6
SW Debug Interface	Yes	Yes	Yes
Watchdog Timer (WDT)	Yes	Yes	Yes

Related Links

[I/O Multiplexing and Considerations](#) on page 21

3. Ordering Information

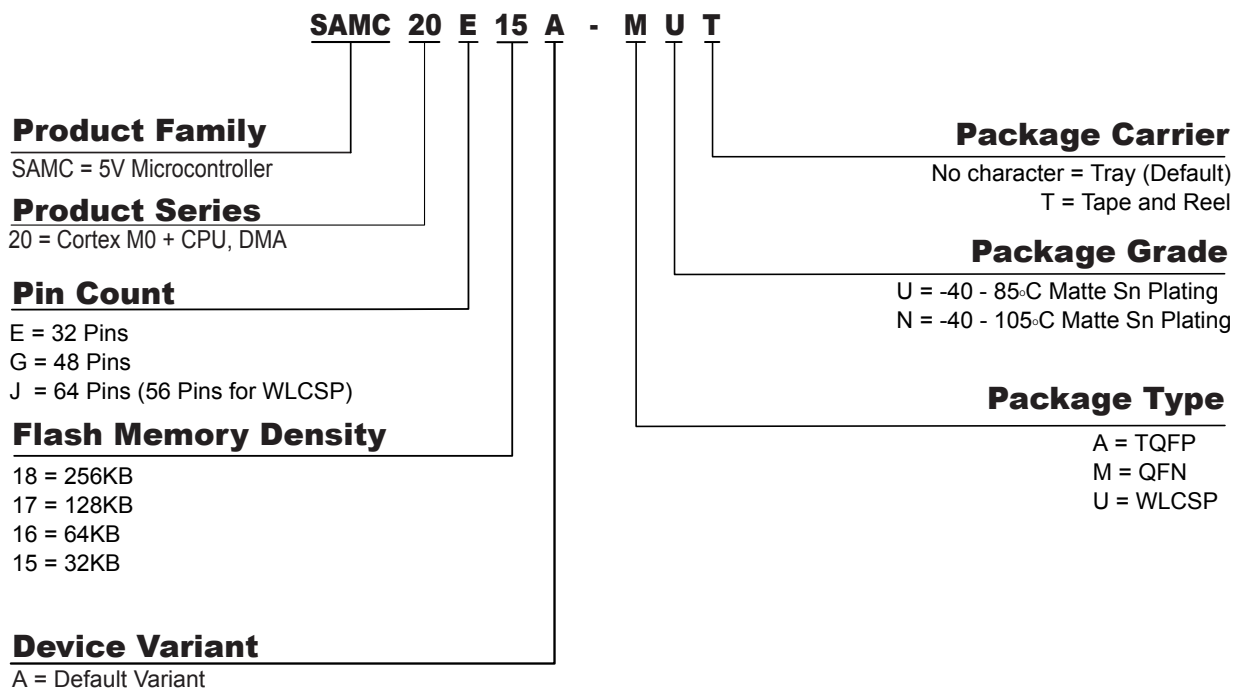

3.1. SAM C20E

Table 3-1. SAM C20E15A Ordering Codes

Ordering Code	FLASH (bytes)	SRAM (bytes)	Package	Carrier Type	Temp
ATSAM C20E15A-AUT	32K	4K	TQFP32	Tape & Reel	85°C
ATSAM C20E15A-ANT	32K	4K	TQFP32	Tape & Reel	105°C
ATSAM C20E15A-MUT	32K	4K	QFN32	Tape & Reel	85°C
ATSAM C20E15A-MNT	32K	4K	QFN32	Tape & Reel	105°C

Table 3-2. SAM C20E16A Ordering Codes

Ordering Code	FLASH (bytes)	SRAM (bytes)	Package	Carrier Type	Temp
ATSAM C20E16A-AUT	64K	8K	TQFP32	Tape & Reel	85°C
ATSAM C20E16A-ANT	64K	8K	TQFP32	Tape & Reel	105°C
ATSAM C20E16A-MUT	64K	8K	QFN32	Tape & Reel	85°C
ATSAM C20E16A-MNT	64K	8K	QFN32	Tape & Reel	105°C

Table 3-3. SAM C20E17A Ordering Codes

Ordering Code	FLASH (bytes)	SRAM (bytes)	Package	Carrier Type	Temp
ATSAM C20E17A-AUT	128K	16K	TQFP32	Tape & Reel	85°C
ATSAM C20E17A-ANT	128K	16K	TQFP32	Tape & Reel	105°C
ATSAM C20E17A-MUT	128K	16K	QFN32	Tape & Reel	85°C
ATSAM C20E17A-MNT	128K	16K	QFN32	Tape & Reel	105°C

Table 3-4. SAM C20E18A Ordering Codes

Ordering Code	FLASH (bytes)	SRAM (bytes)	Package	Carrier Type	Temp
ATSAM C20E18A-AUT	256K	32K	TQFP32	Tape & Reel	85°C
ATSAM C20E18A-ANT	256K	32K	TQFP32	Tape & Reel	105°C
ATSAM C20E18A-MUT	256K	32K	QFN32	Tape & Reel	85°C
ATSAM C20E18A-MNT	256K	32K	QFN32	Tape & Reel	105°C

3.2. SAM C20G

Table 3-5. SAM C20G15A Ordering Codes

Ordering Code	FLASH (bytes)	SRAM (bytes)	Package	Carrier Type	Temp
ATSAM C20G15A-AUT	32K	4K	TQFP48	Tape & Reel	85°C
ATSAM C20G15A-ANT	32K	4K	TQFP48	Tape & Reel	105°C
ATSAM C20G15A-MUT	32K	4K	QFN48	Tape & Reel	85°C
ATSAM C20G15A-MNT	32K	4K	QFN48	Tape & Reel	105°C

Table 3-6. SAM C20G16A Ordering Codes

Ordering Code	FLASH (bytes)	SRAM (bytes)	Package	Carrier Type	Temp
ATSAM C20G16A-AUT	64K	8K	TQFP48	Tape & Reel	85°C
ATSAM C20G16A-ANT	64K	8K	TQFP48	Tape & Reel	105°C
ATSAM C20G16A-MUT	64K	8K	QFN48	Tape & Reel	85°C
ATSAM C20G16A-MNT	64K	8K	QFN48	Tape & Reel	105°C

Table 3-7. SAM C20G17A Ordering Codes

Ordering Code	FLASH (bytes)	SRAM (bytes)	Package	Carrier Type	Temp
ATSAM C20G17A-AUT	128K	16K	TQFP48	Tape & Reel	85°C
ATSAM C20G17A-ANT	128K	16K	TQFP48	Tape & Reel	105°C
ATSAM C20G17A-MUT	128K	16K	QFN48	Tape & Reel	85°C
ATSAM C20G17A-MNT	128K	16K	QFN48	Tape & Reel	105°C

Table 3-8. SAM C20G18A Ordering Codes

Ordering Code	FLASH (bytes)	SRAM (bytes)	Package	Carrier Type	Temp
ATSAM C20G18A-AUT	256K	32K	TQFP48	Tape & Reel	85°C
ATSAM C20G18A-ANT	256K	32K	TQFP48	Tape & Reel	105°C
ATSAM C20G18A-MUT	256K	32K	QFN48	Tape & Reel	85°C
ATSAM C20G18A-MNT	256K	32K	QFN48	Tape & Reel	105°C

3.3. SAM C20J

Table 3-9. SAM C20J15A Ordering Codes

Ordering Code	FLASH (bytes)	SRAM (bytes)	Package	Carrier Type	Temp
ATSAM C20J15A-AUT	32K	4K	TQFP64	Tape & Reel	85°C
ATSAM C20J15A-ANT	32K	4K	TQFP64	Tape & Reel	105°C
ATSAM C20J15A-MUT	32K	4K	QFN64	Tape & Reel	85°C
ATSAM C20J15A-MNT	32K	4K	QFN64	Tape & Reel	105°C

Table 3-10. SAM C20J16A Ordering Codes

Ordering Code	FLASH (bytes)	SRAM (bytes)	Package	Carrier Type	Temp
ATSAM C20J16A-AUT	64K	8K	TQFP64	Tape & Reel	85°C
ATSAM C20J16A-ANT	64K	8K	TQFP64	Tape & Reel	105°C
ATSAM C20J16A-MUT	64K	8K	QFN64	Tape & Reel	85°C
ATSAM C20J16A-MNT	64K	8K	QFN64	Tape & Reel	105°C

Table 3-11. SAM C20J17A Ordering Codes

Ordering Code	FLASH (bytes)	SRAM (bytes)	Package	Carrier Type	Temp
ATSAM C20J17A-AUT	128K	16K	TQFP64	Tape & Reel	85°C
ATSAM C20J17A-ANT	128K	16K	TQFP64	Tape & Reel	105°C
ATSAM C20J17A-MUT	128K	16K	QFN64	Tape & Reel	85°C
ATSAM C20J17A-MNT	128K	16K	QFN64	Tape & Reel	105°C
ATSAM C20J17A-UUT ⁽¹⁾	128K	16K	WLCSP56	Tape & Reel	85°C

1. Contact your local Microchip sales representative for availability.

Table 3-12. SAM C20J18A Ordering Codes

Ordering Code	FLASH (bytes)	SRAM (bytes)	Package	Carrier Type	Temp
ATSAM C20J18A-AUT	256K	32K	TQFP64	Tape & Reel	85°C
ATSAM C20J18A-ANT	256K	32K	TQFP64	Tape & Reel	105°C
ATSAM C20J18A-MUT	256K	32K	QFN64	Tape & Reel	85°C
ATSAM C20J18A-MNT	256K	32K	QFN64	Tape & Reel	105°C
ATSAM C20J18A-UUT ⁽¹⁾	256K	32K	WLCSP56	Tape & Reel	85°C

1. Contact your local Microchip sales representative for availability.

3.4. Device Identification

The DSU - Device Service Unit peripheral provides the Device Selection bits in the Device Identification register (DID.DEVSEL) in order to identify the device by software. The SAM C20 variants have a reset value of DID=0x1101drxx, with the LSB identifying the die number ('d'), the die revision ('r') and the device selection ('xx').

Table 3-13. SAM C20 Device Identification Values

DEVSEL (DID[7:0])	Device
0x00	SAM C20J18A
0x01	SAM C20J17A
0x02	SAM C20J16A
0x03	SAM C20J15A
0x04	Reserved
0x05	SAM C20G18A
0x06	SAM C20G17A
0x07	SAM C20G16A
0x08	SAM C20G15A

DEVSEL (DID[7:0])	Device
0x09	Reserved
0x0A	SAM C20E18A
0x0B	SAM C20E17A
0x0C	SAM C20E16A
0x0D	SAM C20E15A
0x0E-0xFF	Reserved

Note: The device variant (last letter of the ordering number) is independent of the die revision (DSU.DID.REVISION): The device variant denotes functional differences, whereas the die revision marks evolution of the die.

4. Block Diagram

Figure 4-1. System Block Diagram for SAM C20E/G/J

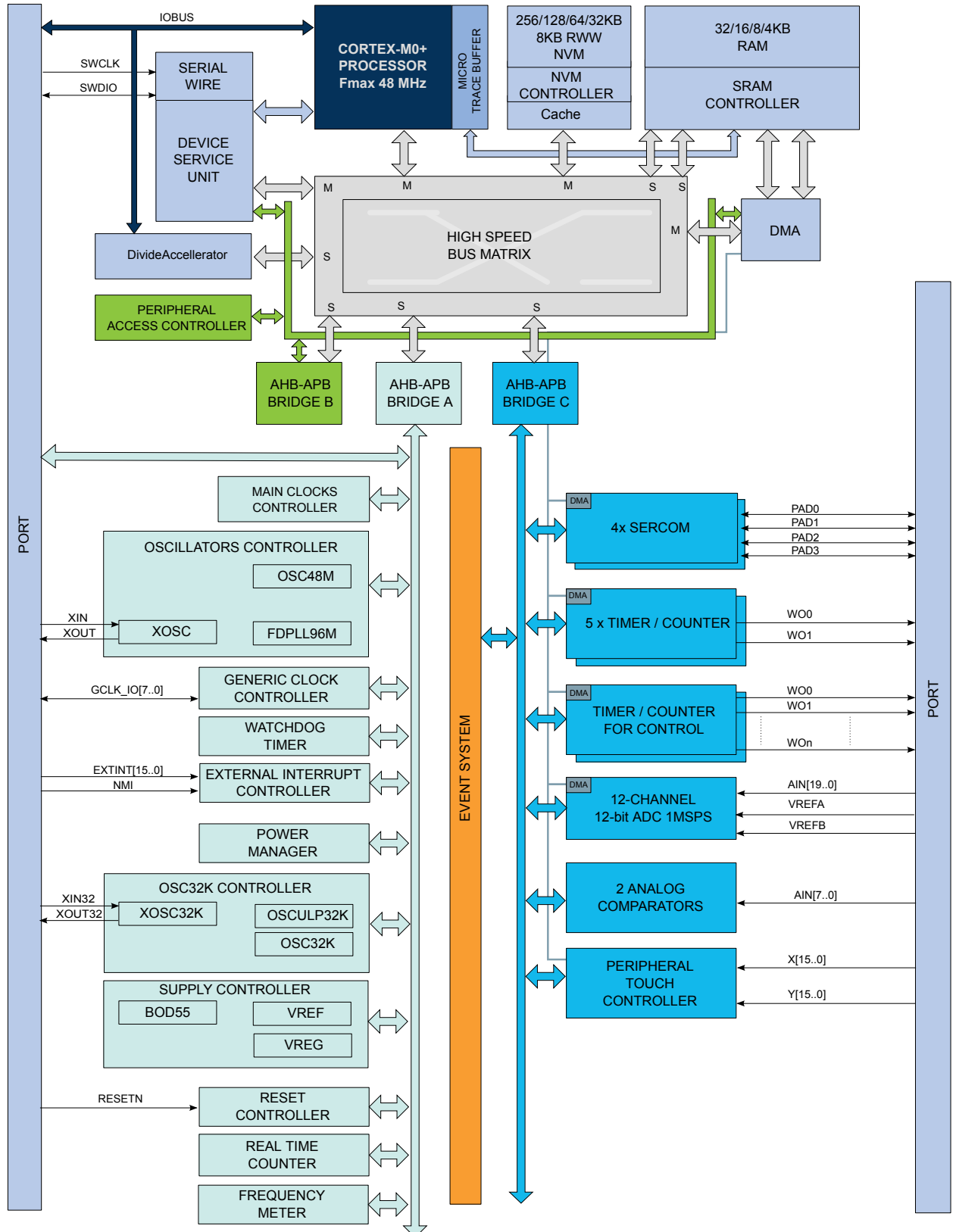

Note:

1. Some products have different number of SERCOM instances, Timer/Counter instances, PTC signals and ADC signals.
2. The three TCC instances have different configurations, including the number of Waveform Output (WO) lines.

Related Links

[TCC Configurations](#) on page 24

[Multiplexed Signals](#) on page 21

5. Pinout

5.1. SAM C20E

5.1.1. QFN32 / TQFP32

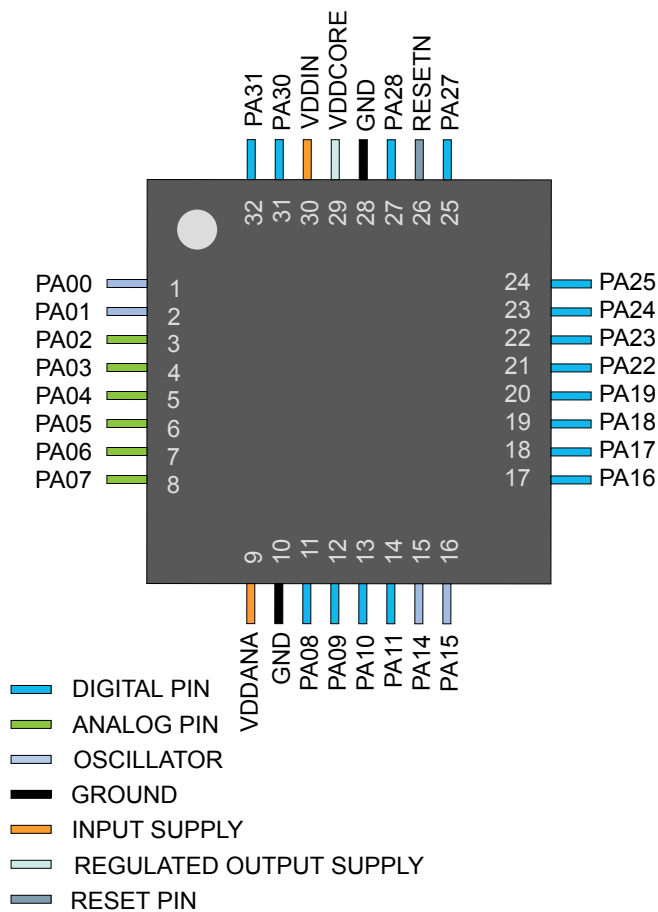

5.2. SAM C20G

5.2.1. QFN48 / TQFP48

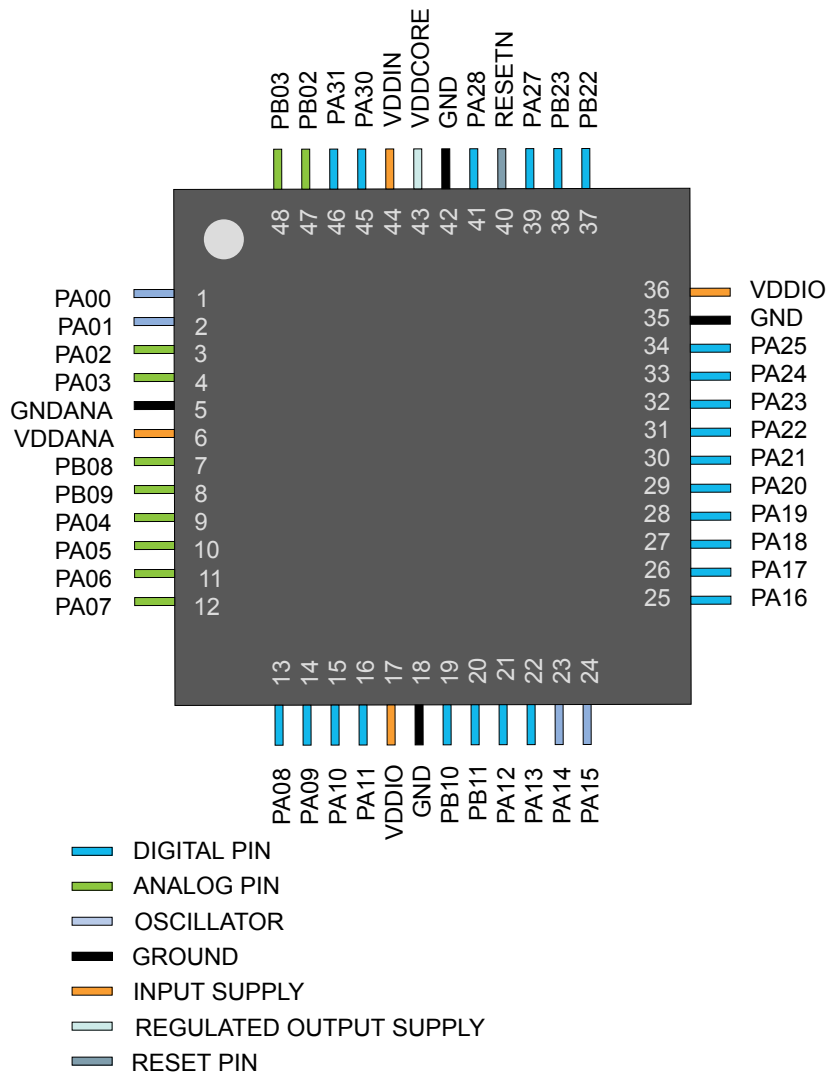

5.3. SAM C20J

5.3.1. QFN64 / TQFP64

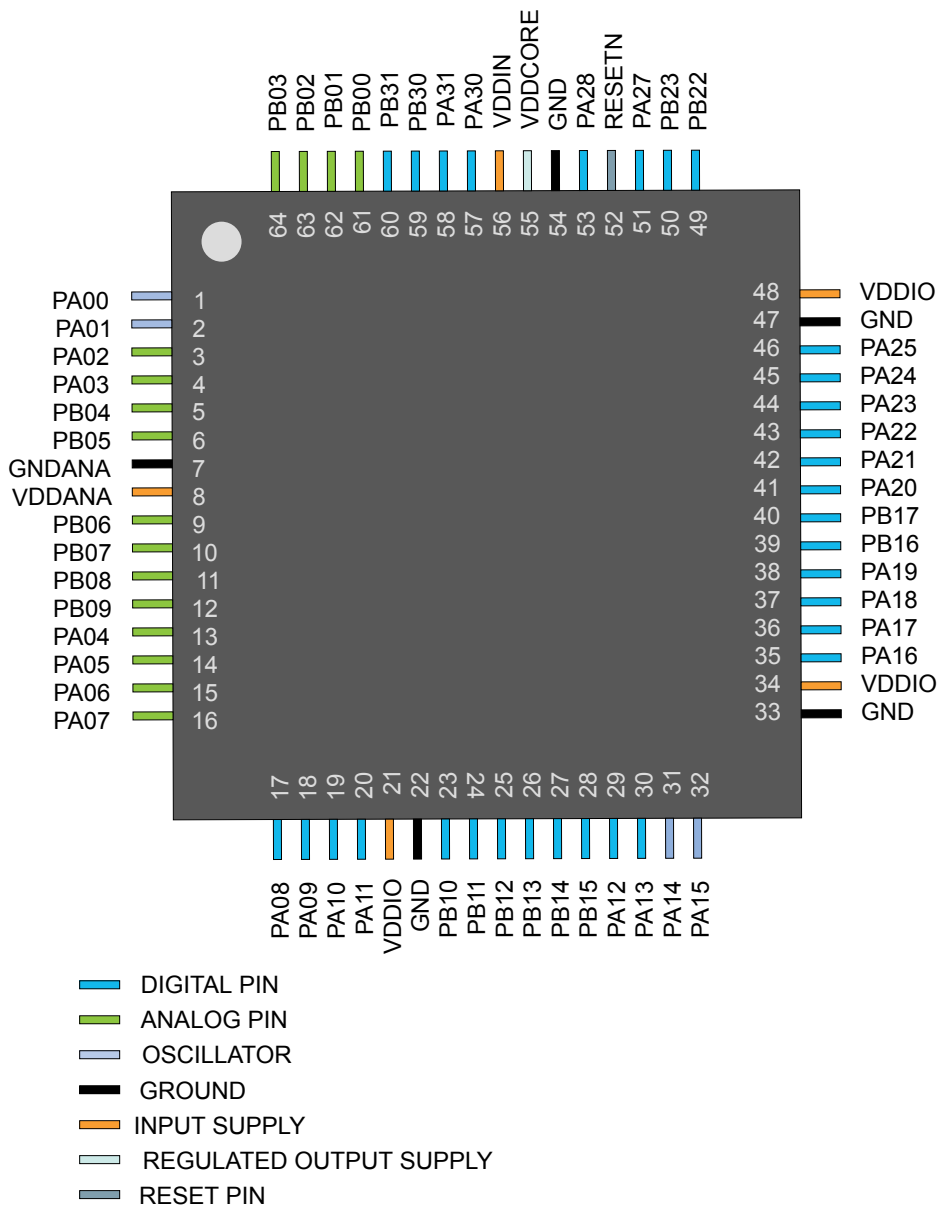

5.3.2. WLCSP56

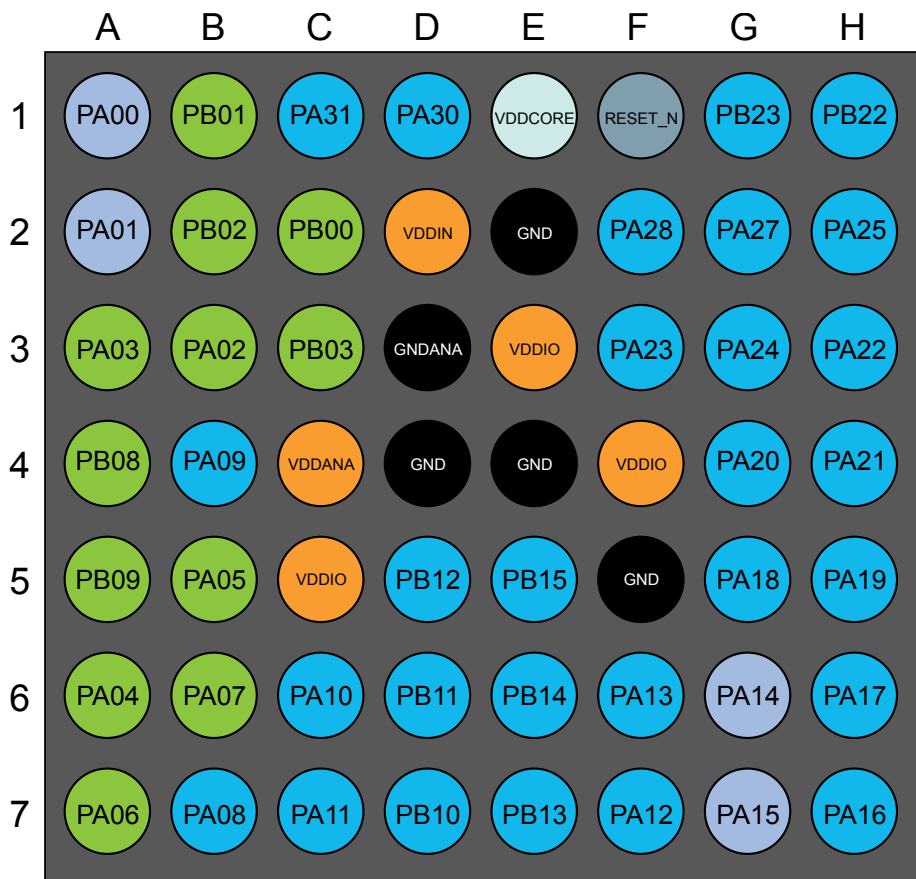

- DIGITAL PIN
- ANALOG PIN
- OSCILLATOR
- GROUND
- INPUT SUPPLY
- REGULATED OUTPUT SUPPLY
- RESET PIN

6. Signal Descriptions List

The following table gives details on signal names classified by peripheral.

Table 6-1. Signal Descriptions List

Signal Name	Function	Type	Active Level
Analog Comparators - AC			
AIN[7:0]	AC Analog Inputs	Analog	
CMP[2:0]	AC Comparator Outputs	Digital	
Analog Digital Converter - ADCx			
AIN[11:0]	ADC Analog Inputs	Analog	
VREFA	ADC Voltage External Reference A	Analog	
External Interrupt Controller - EIC			
EXTINT[15:0]	External Interrupts inputs	Digital	
NMI	External Non-Maskable Interrupt input	Digital	
Generic Clock Generator - GCLK			
GCLK_IO[7:0]	Generic Clock (source clock inputs or generic clock generator output)	Digital	
Custom Control Logic - CCL			
IN[11:0]	Logic Inputs	Digital	
OUT[3:0]	Logic Outputs	Digital	
Power Manager - PM			
RESETN	Reset input	Digital	Low
Serial Communication Interface - SERCOMx			
PAD[3:0]	SERCOM Inputs/Outputs Pads	Digital	
Oscillators Control - OSCCTRL			
XIN	Crystal or external clock Input	Analog/Digital	
XOUT	Crystal Output	Analog	
32KHz Oscillators Control - OSC32CTRL			
XIN32	32KHz Crystal or external clock Input	Analog/Digital	
XOUT32	32KHz Crystal Output	Analog	
Timer Counter - TCx			
WO[1:0]	Waveform Outputs	Digital	
Timer Counter - TCCx			
WO[1:0]	Waveform Outputs	Digital	
Peripheral Touch Controller - PTC			
X[15:0]	PTC Input	Analog	
Y[15:0]	PTC Input	Analog	
General Purpose I/O - PORT			
PA25 - PA00	Parallel I/O Controller I/O Port A	Digital	

Signal Name	Function	Type	Active Level
PA28 - PA27	Parallel I/O Controller I/O Port A	Digital	
PA31 - PA30	Parallel I/O Controller I/O Port A	Digital	
PB17 - PB00	Parallel I/O Controller I/O Port B	Digital	
PB23 - PB22	Parallel I/O Controller I/O Port B	Digital	
PB31 - PB30	Parallel I/O Controller I/O Port B	Digital	

7. I/O Multiplexing and Considerations

7.1. Multiplexed Signals

Each pin is by default controlled by the PORT as a general purpose I/O and alternatively it can be assigned to one of the peripheral functions A, B, C, D, E, F, G, H or I. To enable a peripheral function on a pin, the Peripheral Multiplexer Enable bit in the Pin Configuration register corresponding to that pin (PINCFGn.PMUXEN, n = 0-31) in the PORT must be written to one. The selection of peripheral function A to H is done by writing to the Peripheral Multiplexing Odd and Even bits in the Peripheral Multiplexing register (PMUXn.PMUXE/O) in the PORT.

Table 7-1. PORT Function Multiplexing

SAM C20E	Pin ⁽¹⁾		I/O Pin	Supply	A	REF	B ⁽²⁾⁽³⁾			C	D	E	F	G	H	I
	SAM C20G	SAM C20J					ADC0	AC	PTC							
1	1	1	PA00	VDDANA	EXTINT[0]						SERCOM1/ PAD[0]				CMP[2]	
2	2	2	PA01	VDDANA	EXTINT[1]						SERCOM1/ PAD[1]				CMP[3]	
3	3	3	PA02	VDDANA	EXTINT[2]			AIN[0]	AIN[4]	Y[0]						
4	4	4	PA03	VDDANA	EXTINT[3]	ADC/VREFA		AIN[1]	AIN[5]	Y[1]						
		5	PB04	VDDANA	EXTINT[4]					Y[10]						
		6	PB05	VDDANA	EXTINT[5]				AIN[6]	Y[11]						
		9	PB06	VDDANA	EXTINT[6]				AIN[7]	Y[12]						CCL2/ IN[6]
		10	PB07	VDDANA	EXTINT[7]					Y[13]						CCL2/ IN[7]
	7	11	PB08	VDDANA	EXTINT[8]			AIN[2]		Y[14]		TC0/WO[0]				CCL2/ IN[8]
	8	12	PB09	VDDANA	EXTINT[9]			AIN[3]		Y[15]		TC0WO[1]				CCL2/ OUT[2]
5	9	13	PA04	VDDANA	EXTINT[4]			AIN[4]	AIN[0]	Y[2]		SERCOM0/ PAD[0]	TCC0/WO[0]			CCL0/ IN[0]
6	10	14	PA05	VDDANA	EXTINT[5]			AIN[5]	AIN[1]	Y[3]		SERCOM0/ PAD[1]	TCC0/WO[1]			CCL0/ IN[1]
7	11	15	PA06	VDDANA	EXTINT[6]			AIN[6]	AIN[2]	Y[4]		SERCOM0/ PAD[2]				CCL0/ IN[2]
8	12	16	PA07	VDDANA	EXTINT[7]			AIN[7]	AIN[3]	Y[5]		SERCOM0/ PAD[3]				CCL0/ OUT[0]
11	13	17	PA08	VDDIO	NMI			AIN[8]		X[0]/Y[16]	SERCOM0/ PAD[0]	SERCOM2/ PAD[0]	TCC0/WO[0]			CCL1/ IN[3]
12	14	18	PA09	VDDIO	EXTINT[9]			AIN[9]		X[1]/Y[17]	SERCOM0/ PAD[1]	SERCOM2/ PAD[1]	TCC0/WO[1]			CCL1/ IN[4]
13	15	19	PA10	VDDIO	EXTINT[10]			AIN[10]		X[2]/Y[18]	SERCOM0/ PAD[2]	SERCOM2/ PAD[2]	TCC0/ WO[2]		GCLK_IO[4]	CCL1/ IN[5]
14	16	20	PA11	VDDIO	EXTINT[11]			AIN[11]		X[3]/Y[19]	SERCOM0/ PAD[3]	SERCOM2/ PAD[3]	TCC0/ WO[3]		GCLK_IO[5]	CCL1/ OUT[1]
		19	PB10	VDDIO	EXTINT[10]								TC1/WO[0]	TCC0/ WO[4]	GCLK_IO[4]	CCL1/ IN[5]
		20	PB11	VDDIO	EXTINT[11]								TC1/WO[1]	TCC0/ WO[5]	GCLK_IO[5]	CCL1/ OUT[1]
		25	PB12	VDDIO	EXTINT[12]					X[12]/Y[28]			TC0/WO[0]	TCC0/ WO[6]	GCLK_IO[6]	
		26	PB13	VDDIO	EXTINT[13]					X[13]/Y[29]			TC0/WO[1]	TCC0/ WO[7]	GCLK_IO[7]	
		27	PB14	VDDIO	EXTINT[14]					X[14]/Y[30]			TC1/WO[0]		GCLK_IO[0]	CCL3/ IN[9]
		28	PB15	VDDIO	EXTINT[15]					X[15]/Y[31]			TC1/WO[1]		GCLK_IO[1]	CCL3/ IN[10]
	21	29	PA12	VDDIO	EXTINT[12]						SERCOM2/ PAD[0]		TCC0/ WO[6]		AC/CMP[0]	
	22	30	PA13	VDDIO	EXTINT[13]						SERCOM2/ PAD[1]		TCC0/ WO[7]		AC/CMP[1]	
15	23	31	PA14	VDDIO	EXTINT[14]						SERCOM2/ PAD[2]		TC4/WO[0]	TCC0/ WO[4]	GCLK_IO[0]	
16	24	32	PA15	VDDIO	EXTINT[15]						SERCOM2/ PAD[3]		TC4/WO[1]	TCC0/ WO[5]	GCLK_IO[1]	
17	25	35	PA16	VDDIO	EXTINT[0]					X[4]/Y[20]	SERCOM3/ PAD[0]	SERCOM3/ PAD[0]	TCC0/ WO[6]		GCLK_IO[2]	CCL0/ IN[0]

SAM C20E	Pin ⁽¹⁾	SAM C20G	SAM C20J	I/O Pin	Supply	A	REF	ADC0	B ⁽²⁾⁽³⁾	AC	PTC	C	D	E	F	G	H	I
						EIC						SERCOM ₁ /PAD ₁ (3)	SERCOM-ALT	TC	TCC	COM	AC/GCLK	CCL
18	26	36	PA17	VDDIO	EXTINT[1]						X[5]/Y[21]	SERCOM ₁ /PAD ₁	SERCOM ₃ /PAD ₁		TCC0/WO[7]		GCLK_IO[3]	CCL0/IN[1]
19	27	37	PA18	VDDIO	EXTINT[2]						X[6]/Y[22]	SERCOM ₁ /PAD ₂	SERCOM ₃ /PAD ₂	TC4/WO[0]	TCC0/WO[2]		AC/CMP[0]	CCL0/IN[2]
20	28	38	PA19	VDDIO	EXTINT[3]						X[7]/Y[23]	SERCOM ₁ /PAD ₃	SERCOM ₃ /PAD ₃	TC4/WO[1]	TCC0/WO[3]		AC/CMP[1]	CCL0/OUT[0]
		39	PB16	VDDIO	EXTINT[0]									TC2/WO[0]	TCC0/WO[4]		GCLK_IO[2]	CCL3/IN[11]
		40	PB17	VDDIO	EXTINT[1]									TC2/WO[1]	TCC0/WO[5]		GCLK_IO[3]	CCL3/OUT[3]
	29	41	PA20	VDDIO	EXTINT[4]						X[8]/Y[24]		SERCOM ₃ /PAD ₂	TC3/WO[0]	TCC0/WO[6]		GCLK_IO[4]	
	30	42	PA21	VDDIO	EXTINT[5]						X[9]/Y[25]		SERCOM ₃ /PAD ₃	TC3/WO[1]	TCC0/WO[7]		GCLK_IO[5]	
21	31	43	PA22	VDDIO	EXTINT[6]						X[10]/Y[26]	SERCOM ₃ /PAD ₀		TC0/WO[0]	TCC0/WO[4]		GCLK_IO[6]	CCL2/IN[6]
22	32	44	PA23	VDDIO	EXTINT[7]						X[11]/Y[27]	SERCOM ₃ /PAD ₁		TC0/WO[1]	TCC0/WO[5]		GCLK_IO[7]	CCL2/IN[7]
23	33	45	PA24	VDDIO	EXTINT[12]							SERCOM ₃ /PAD ₂		TC1/WO[0]			AC/CMP[2]	CCL2/IN[8]
24	34	46	PA25	VDDIO	EXTINT[13]							SERCOM ₃ /PAD ₃		TC1/WO[1]			AC/CMP[3]	CCL2/OUT[2]
		37	PA22	VDDIN	EXTINT[6]									TC3/WO[0]			GCLK_IO[0]	CCL0/IN[0]
		38	PB23	VDDIN	EXTINT[7]									TC3/WO[1]			GCLK_IO[1]	CCL0/OUT[0]
25	39	51	PA27	VDDIN	EXTINT[15]											BRK	GCLK_IO[0]	
27	41	53	PA28	VDDIN	EXTINT[8]												GCLK_IO[0]	
31	45	57	PA30	VDDIN	EXTINT[10]								SERCOM ₁ /PAD ₂			CORTEX_M0P/SWCLK	GCLK_IO[0]	CCL1/IN[3]
32	46	58	PA31	VDDIN	EXTINT[11]								SERCOM ₁ /PAD ₃			CORTEX_M0P/SWDIO		CCL1/OUT[1]
		59	PB30	VDDIN	EXTINT[14]									TC0/WO[0]			AC/CMP[2]	
		60	PB31	VDDIN	EXTINT[15]									TC0/WO[1]			AC/CMP[3]	
		61	PB00	VDDANA	EXTINT[0]						Y[6]			TC3/WO[0]				CCL0/IN[1]
		62	PB01	VDDANA	EXTINT[1]						Y[7]			TC3/WO[1]				CCL0/IN[2]
	47	63	PB02	VDDANA	EXTINT[2]						Y[8]			TC2/WO[0]				CCL0/OUT[0]
	48	64	PB03	VDDANA	EXTINT[3]						Y[9]			TC2/WO[1]				

1. Use the SAM C21J pinout muxing for the WLCSP56 package.
2. All analog pin functions are on peripheral function B. Peripheral function B must be selected to disable the digital control of the pin.
3. Only some pins can be used in SERCOM I2C mode. Refer to [SERCOM I2C Pins](#).

Related Links

[SERCOM I2C Pins](#) on page 23

7.2. Other Functions

7.2.1. Oscillator Pinout

The oscillators are not mapped to the normal PORT functions and their multiplexing are controlled by registers in the Oscillators Controller (OSCCTRL) and in the 32K Oscillators Controller (OSC32KCTRL).

Table 7-2. Oscillator Pinout

Oscillator	Supply	Signal	I/O pin
XOSC	VDDIO	XIN	PA14
		XOUT	PA15

Oscillator	Supply	Signal	I/O pin
XOSC32K	VDDANA	XIN32	PA00
		XOUT32	PA01

7.2.2. Serial Wire Debug Interface Pinout

Only the SWCLK pin is mapped to the normal PORT functions. A debugger cold-plugging or hot-plugging detection will automatically switch the SWDIO port to the SWDIO function.

Table 7-3. Serial Wire Debug Interface Pinout

Signal	Supply	I/O pin
SWCLK	VDDIN	PA30
SWDIO	VDDIN	PA31

7.2.3. SERCOM I²C Pins

Table 7-4. SERCOM Pins Supporting I²C

Device	Pins Supporting I ² C Hs mode
SAM C20E	PA08, PA09, PA10, PA11, PA16, PA17, PA22, PA23
SAM C20G	PA08, PA09, PA10, PA11, PA12, PA13, PA16, PA17, PA22, PA23, PB10, PB11
SAM C20J	PA08, PA09, PA10, PA11, PA12, PA13, PA16, PA17, PA22, PA23, PB10, PB11, PB12, PB13, PB16, PB17, PB30, PB31

7.2.4. GPIO Clusters

Table 7-5. GPIO Clusters

Package	Cluster	GPIO	Supplies Pin connected to the cluster	
64 pins	1	PB31 PB30 PA31 PA30 PA28 PA27	VDDIN (56)	GND (54)
	2	PB23 PB22	VDDIO (48)	GND (54+47)
	3	PA25 PA24 PA23 PA22 PA21 PA20 PB17 PB16 PA19 PA18 PA17 PA16	VDDIO (48+34)	GND (47+33)
	4	PA15 PA14 PA13 PA12 PB15 PB14 PB13 PB12 PB11 PB10	VDDIO (34+21)	GND (33+22)
	5	PA11 PA10 PA08 PA09	VDDIO (21)	GND (22)
	6	PA07 PA06 PA05 PA04 PB09 PB08 PB07 PB06 PB05 PB04 PA03 PA02 PA01 PA00 PB03 PB02 PB01 PB00	VDDANA (8)	GNDANA (7)

Package	Cluster	GPIO	Supplies Pin connected to the cluster	
48 pins	1	PA31 PA30 PA28 PA27	VDDIN (44)	GND (42)
	2	PB23 PB22	VDDIO (36)	GND (42+35)
	3	PA25 PA24 PA23 PA22 PA21 PA20 PA19 PA18 PA17 PA16 PA15 PA14 PA13 PA12 PB11 PB10	VDDIO (36+17)	GND (35+18)
	4	PA11 PA10 PA08 PA09	VDDIO (17)	GND (18)
	5	PA07 PA06 PA05 PA04 PB09 PB08 PA03 PA02 PA01 PA00 PB03 PB02	VDDANA (6)	GNDANA (5)
32 pins	1	PA31 PA30 PA28 PA27	VDDIN (30)	GND (28)
	2	PA25 PA24 PA23 PA22 PA19 PA18 PA17 PA16 PA15 PA14 PA11 PA10 PA08 PA09	VDDIO (9)	GND (28+10)
	3	PA07 PA06 PA05 PA04 PA03 PA02 PA01 PA00	VDDANA (9)	GND (28+10)

7.2.5. TCC Configurations

The SAM C20 has one instance of the Timer/Counter for Control applications (TCC) peripheral, . The following table lists the features for each TCC instance.

Table 7-6. TCC Configuration Summary

TCC#	Channels (CC_NUM)	Waveform Output (WO_NUM)	Counter size	Fault	Dithering	Output matrix	Dead Time Insertion (DTI)	SWAP	Pattern generation
0	4	8	24-bit	Yes	Yes	Yes	Yes	Yes	Yes

Note: The number of CC registers (CC_NUM) for each TCC corresponds to the number of compare/capture channels, so that a TCC can have more Waveform Outputs (WO_NUM) than CC registers.

8. Product Mapping

Figure 8-1. SAM C20 Product Mapping

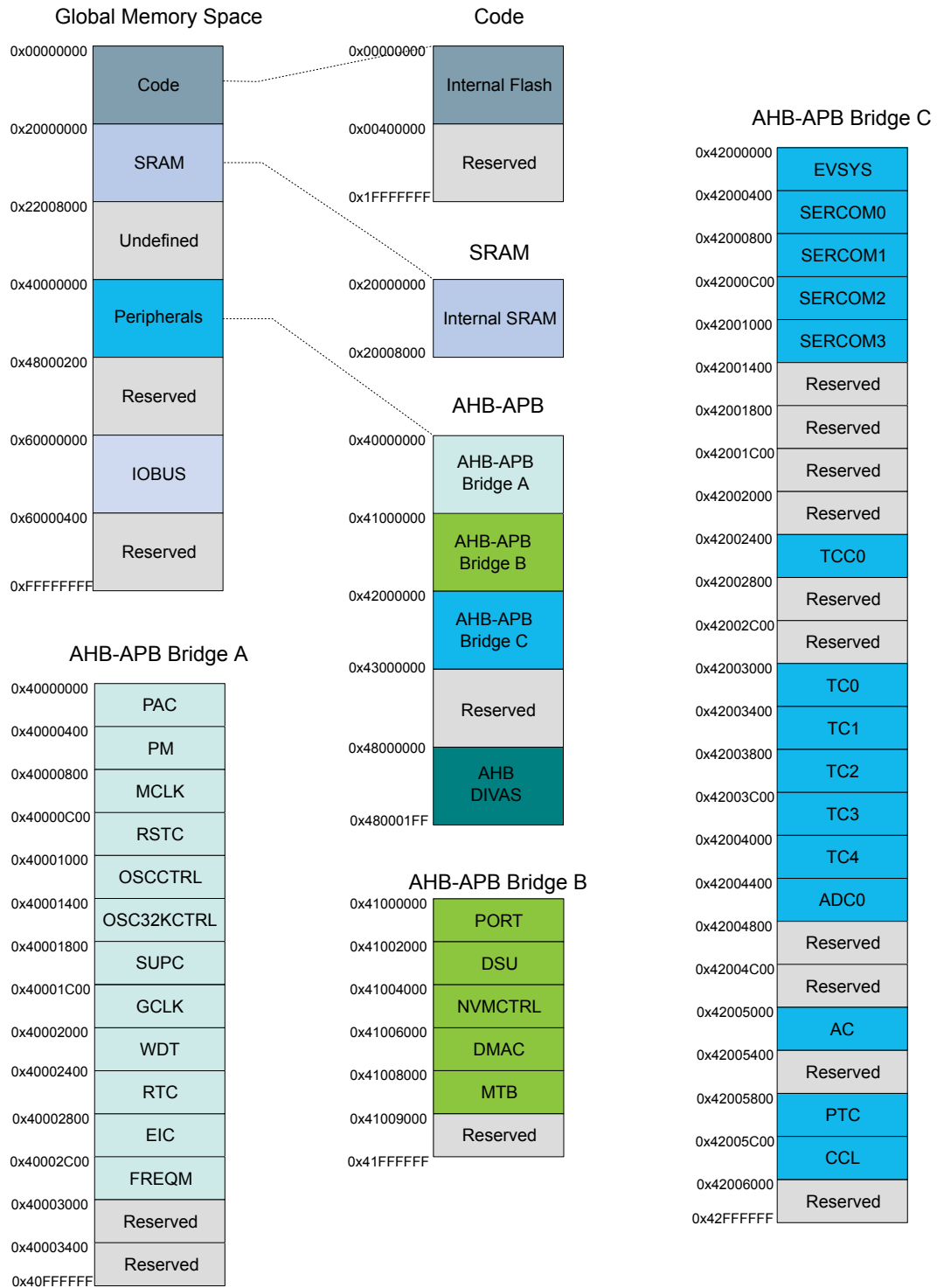

9. Processor and Architecture

9.1. Cortex M0+ Processor

The Atmel SAM C20 implements the ARM® Cortex™-M0+ processor, based on the ARMv6 Architecture and Thumb®-2 ISA. The Cortex M0+ is 100% instruction set compatible with its predecessor, the Cortex-M0 core, and upward compatible to Cortex-M3 and M4 cores. The implemented ARM Cortex-M0+ is revision r0p1. For more information refer to <http://www.arm.com>.

9.1.1. Cortex M0+ Configuration

Table 9-1. Cortex M0+ Configuration

Features	Cortex-M0+ options	SAM C20 configuration
Interrupts	External interrupts 0-32	32
Data endianness	Little-endian or big-endian	Little-endian
SysTick timer	Present or absent	Present
Number of watchpoint comparators	0, 1, 2	2
Number of breakpoint comparators	0, 1, 2, 3, 4	4
Halting debug support	Present or absent	Present
Multiplier	Fast or small	Fast (single cycle)
Single-cycle I/O port	Present or absent	Present
Wake-up interrupt controller	Supported or not supported	Not supported
Vector Table Offset Register	Present or absent	Present
Unprivileged/Privileged support	Present or absent	Present
Memory Protection Unit	Not present or 8-region	8-region
Reset all registers	Present or absent	Absent
Instruction fetch width	16-bit only or mostly 32-bit	32-bit

The ARM Cortex-M0+ core has two bus interfaces:

- Single 32-bit AMBA-3 AHB-Lite system interface that provides connections to peripherals and all system memory, which includes flash and RAM.
- Single 32-bit I/O port bus interfacing to the PORT and DIVAS with 1-cycle loads and stores.

9.1.2. Cortex-M0+ Peripherals

- System Control Space (SCS)
 - The processor provides debug through registers in the SCS. Refer to the Cortex-M0+ Technical Reference Manual for details (<http://www.arm.com>).
- Nested Vectored Interrupt Controller (NVIC)
 - External interrupt signals connect to the NVIC, and the NVIC prioritizes the interrupts. Software can set the priority of each interrupt. The NVIC and the Cortex-M0+ processor core are closely coupled, providing low latency interrupt processing and efficient processing of late

arriving interrupts. Refer to [Nested Vector Interrupt Controller](#) and the Cortex-M0+ Technical Reference Manual for details (<http://www.arm.com>).

- System Timer (SysTick)
 - The System Timer is a 24-bit timer clocked by CLK_CPU that extends the functionality of both the processor and the NVIC. Refer to the Cortex-M0+ Technical Reference Manual for details (<http://www.arm.com>).
- System Control Block (SCB)
 - The System Control Block provides system implementation information, and system control. This includes configuration, control, and reporting of the system exceptions. Refer to the Cortex-M0+ Devices Generic User Guide for details (<http://www.arm.com>).
- Micro Trace Buffer (MTB)
 - The CoreSight MTB-M0+ (MTB) provides a simple execution trace capability to the Cortex-M0+ processor. Refer to section [Micro Trace Buffer](#) and the CoreSight MTB-M0+ Technical Reference Manual for details (<http://www.arm.com>).
- Memory Protection Unit (MPU)
 - The Memory Protection Unit divides the memory map into a number of regions, and defines the location, size, access permissions and memory attributes of each region. Refer to the Cortex-M0+ Devices Generic User Guide for details (<http://www.arm.com>).

9.1.3. Cortex-M0+ Address Map

Table 9-2. Cortex-M0+ Address Map

Address	Peripheral
0xE000E000	System Control Space (SCS)
0xE000E010	System Timer (SysTick)
0xE000E100	Nested Vectored Interrupt Controller (NVIC)
0xE000ED00	System Control Block (SCB)
0x41008000	Micro Trace Buffer (MTB)

Related Links

[Product Mapping](#) on page 25

9.1.4. I/O Interface

9.1.4.1. Overview

Because accesses to the AMBA® AHB-Lite™ and the single cycle I/O interface can be made concurrently, the Cortex-M0+ processor can fetch the next instructions while accessing the I/Os. This enables single cycle I/O accesses to be sustained for as long as needed.

9.1.4.2. Description

Direct access to PORT registers and DIVAS registers.

9.2. Nested Vector Interrupt Controller

9.2.1. Overview

The Nested Vectored Interrupt Controller (NVIC) in the SAM C20 supports 32 interrupt lines with four different priority levels. For more details, refer to the Cortex-M0+ Technical Reference Manual (<http://www.arm.com>).

9.2.2. Interrupt Line Mapping

Each of the interrupt lines is connected to one peripheral instance, as shown in the table below. Each peripheral can have one or more interrupt flags, located in the peripheral's Interrupt Flag Status and Clear (INTFLAG) register.

The interrupt flag is set when the interrupt condition occurs. Each interrupt in the peripheral can be individually enabled by writing a one to the corresponding bit in the peripheral's Interrupt Enable Set (INTENSET) register, and disabled by writing a one to the corresponding bit in the peripheral's Interrupt Enable Clear (INTENCLR) register.

An interrupt request is generated from the peripheral when the interrupt flag is set and the corresponding interrupt is enabled.

The interrupt requests for one peripheral are ORed together on system level, generating one interrupt request for each peripheral. An interrupt request will set the corresponding interrupt pending bit in the NVIC interrupt pending registers (SETPEND/CLRPEND bits in ISPR/ICPR).

For the NVIC to activate the interrupt, it must be enabled in the NVIC interrupt enable register (SETENA/CLRENA bits in ISER/ICER). The NVIC interrupt priority registers IPR0-IPR7 provide a priority field for each interrupt.

Table 9-3. Interrupt Line Mapping

Peripheral Source	NVIC Line
EIC NMI – External Interrupt Controller	NMI
PM – Power Manager MCLK - Main Clock OSCCTRL - Oscillators Controller OSC32KCTRL - 32kHz Oscillators Controller SUPC - Supply Controller PAC - Protection Access Controller	0
WDT – Watchdog Timer	1
RTC – Real Time Clock	2
EIC – External Interrupt Controller	3
FREQM – Frequency Meter	4
Reserved	5
NVMCTRL – Non-Volatile Memory Controller	6
DMAC - Direct Memory Access Controller	7
EVSYS – Event System	8
SERCOM0 – Serial Communication Controller 0	9
SERCOM1 – Serial Communication Controller 1	10
SERCOM2 – Serial Communication Controller 2	11
SERCOM3 – Serial Communication Controller 3	12

Peripheral Source	NVIC Line
Reserved	13
Reserved	14
Reserved	15
Reserved	16
TCC0 – Timer Counter for Control 0	17
Reserved	18
Reserved	19
TC0 – Timer Counter 0	20
TC1 – Timer Counter 1	21
TC2 – Timer Counter 2	22
	23
	24
ADC0 – Analog-to-Digital Converter 0	25
Reserved	26
AC – Analog Comparator	27
Reserved	28
Reserved	29
PTC – Peripheral Touch Controller	30
Reserved	31

9.3. Micro Trace Buffer

9.3.1. Features

- Program flow tracing for the Cortex-M0+ processor
- MTB SRAM can be used for both trace and general purpose storage by the processor
- The position and size of the trace buffer in SRAM is configurable by software
- CoreSight compliant

9.3.2. Overview

When enabled, the MTB records changes in program flow, reported by the Cortex-M0+ processor over the execution trace interface shared between the Cortex-M0+ processor and the CoreSight MTB-M0+. This information is stored as trace packets in the SRAM by the MTB. An off-chip debugger can extract the trace information using the Debug Access Port to read the trace information from the SRAM. The debugger can then reconstruct the program flow from this information.

The MTB simultaneously stores trace information into the SRAM, and gives the processor access to the SRAM. The MTB ensures that trace write accesses have priority over processor accesses.

The execution trace packet consists of a pair of 32-bit words that the MTB generates when it detects the processor PC value changes non-sequentially. A non-sequential PC change can occur during branch instructions or during exception entry. See the CoreSight MTB-M0+ Technical Reference Manual for more details on the MTB execution trace packet format.

Tracing is enabled when the MASTER.EN bit in the Master Trace Control Register is 1. There are various ways to set the bit to 1 to start tracing, or to 0 to stop tracing. See the CoreSight Cortex-M0+ Technical Reference Manual for more details on the Trace start and stop and for a detailed description of the MTB's MASTER register. The MTB can be programmed to stop tracing automatically when the memory fills to a specified watermark level or to start or stop tracing by writing directly to the MASTER.EN bit. If the watermark mechanism is not being used and the trace buffer overflows, then the buffer wraps around overwriting previous trace packets.

The base address of the MTB registers is 0x41008000; this address is also written in the CoreSight ROM Table. The offset of each register from the base address is fixed and as defined by the CoreSight MTB-M0+ Technical Reference Manual. The MTB has 4 programmable registers to control the behavior of the trace features:

- POSITION: Contains the trace write pointer and the wrap bit,
- MASTER: Contains the main trace enable bit and other trace control fields,
- FLOW: Contains the WATERMARK address and the AUTOSTOP and AUTOHALT control bits,
- BASE: Indicates where the SRAM is located in the processor memory map. This register is provided to enable auto discovery of the MTB SRAM location, by a debug agent.

See the CoreSight MTB-M0+ Technical Reference Manual for a detailed description of these registers.

9.4. High-Speed Bus System

9.4.1. Features

High-Speed Bus Matrix has the following features:

- Symmetric crossbar bus switch implementation
- Allows concurrent accesses from different masters to different slaves
- 32-bit data bus
- Operation at a 1-to-1 clock frequency with the bus masters

9.4.2. Configuration

Figure 9-1. Master-Slave Relation High-Speed Bus Matrix

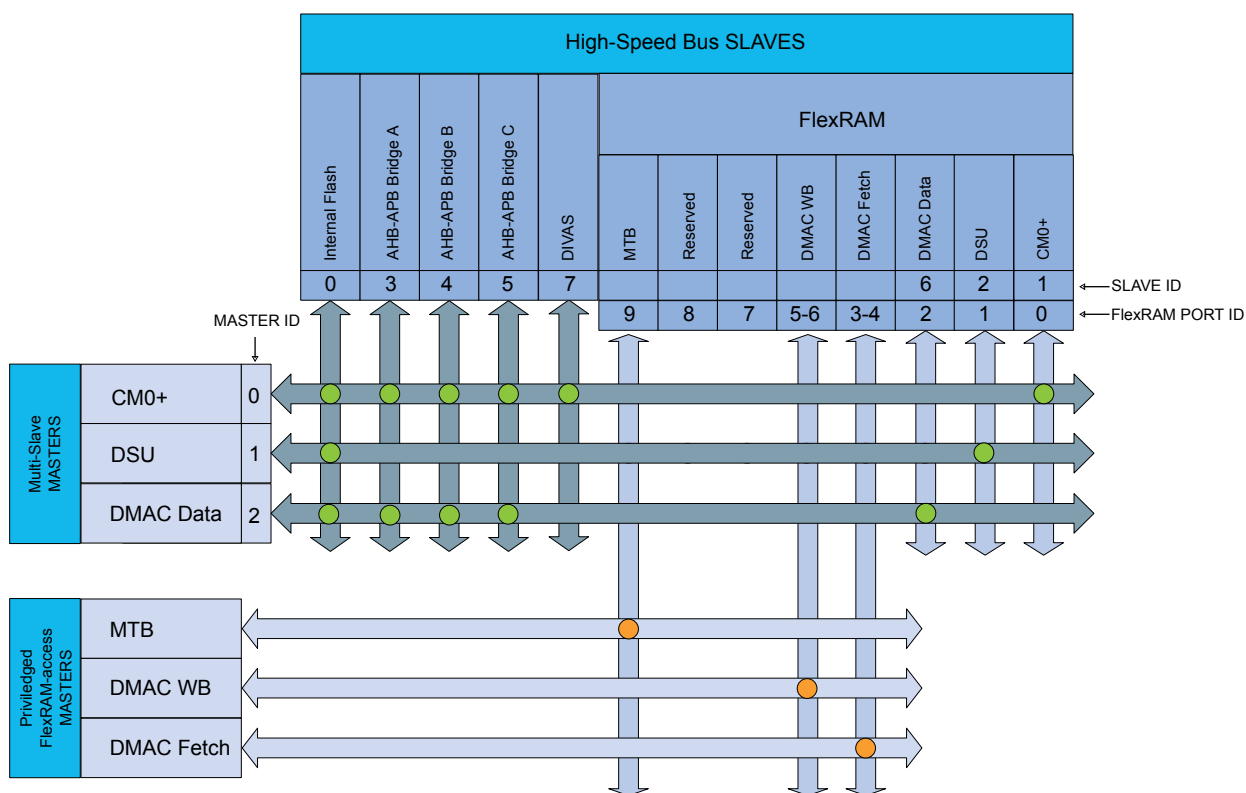

Table 9-4. Bus Matrix Masters

Bus Matrix Masters	Master ID
CM0+ - Cortex M0+ Processor	0
DSU - Device Service Unit	1
DMAC - Direct Memory Access Controller / Data Access	2

Table 9-5. Bus Matrix Slaves

Bus Matrix Slaves	Slave ID
Internal Flash Memory	0
SRAM Port 4 - CM0+ Access	1
SRAM Port 6 - DSU Access	2
AHB-APB Bridge A	3
AHB-APB Bridge B	4
AHB-APB Bridge C	5
SRAM Port 5 - DMAC Data Access	6
DIVAS - Divide Accelerator	7

Table 9-6. SRAM Port Connections

SRAM Port Connection	Port ID	Connection Type
CM0+ - Cortex M0+ Processor	0	Bus Matrix
DSU - Device Service Unit	1	Bus Matrix
DMAC - Direct Memory Access Controller - Data Access	2	Bus Matrix
DMAC - Direct Memory Access Controller - Fetch Access 0	3	Direct
DMAC - Direct Memory Access Controller - Fetch Access 1	4	Direct
DMAC - Direct Memory Access Controller - Write-Back Access 0	5	Direct
DMAC - Direct Memory Access Controller - Write-Back Access 1	6	Direct
Reserved	7	Direct
Reserved	8	Direct
MTB - Micro Trace Buffer	9	Direct

9.4.3. SRAM Quality of Service

To ensure that masters with latency requirements get sufficient priority when accessing RAM, the different masters can be configured to have a given priority for different type of access.

The Quality of Service (QoS) level is independently selected for each master accessing the RAM. For any access to the RAM the RAM also receives the QoS level. The QoS levels and their corresponding bit values for the QoS level configuration is shown in below.

Table 9-7. Quality of Service Level Configuration

Value	Name	Description
0x0	DISABLE	Background (no sensitive operation)
0x1	LOW	Sensitive Bandwidth
0x2	MEDIUM	Sensitive Latency
0x3	HIGH	Critical Latency

If a master is configured with QoS level DISABLE (0x0) or LOW (0x1) there will be minimum latency of one cycle for the RAM access.

The priority order for concurrent accesses are decided by two factors. First, the QoS level for the master and second, a static priority given by [Table 9-6](#). The lowest port ID has the highest static priority.

The MTB has fixed QoS level HIGH (0x3) and the DSU has fixed QoS level LOW (0x1).

The CPU QoS level can be written/read at address 0x41007110, bits [1:0]. Its reset value is 0x0.

Refer to different master QOSCTRL registers for configuring QoS for the other masters (DMAC).

10. Packaging Information

10.1. Thermal Considerations

10.1.1. Thermal Resistance Data

The following table summarizes the thermal resistance data depending on the package.

Table 10-1. Thermal Resistance Data

Package Type	θ_{JA}	θ_{JC}
32-pin TQFP	68°C/W	25.8°C/W
48-pin TQFP	78.8°C/W	12.3°C/W
64-pin TQFP	66.7°C/W	11.9°C/W
32-pin QFN	37.2°C/W	3.1°C/W
48-pin QFN	31.6°C/W	10.3°C/W
64-pin QFN	32.2°C/W	10.1°C/W
56-ball WLCSP	37.5°C/W	5.48°C/W

10.1.2. Junction Temperature

The average chip-junction temperature, T_J , in °C can be obtained from the following:

1. $T_J = T_A + (P_D \times \theta_{JA})$
2. $T_J = T_A + (P_D \times (\theta_{HEATSINK} + \theta_{JC}))$

where:

- θ_{JA} = Package thermal resistance, Junction-to-ambient (°C/W), see Thermal Resistance Data
- θ_{JC} = Package thermal resistance, Junction-to-case thermal resistance (°C/W), see Thermal Resistance Data
- $\theta_{HEATSINK}$ = Thermal resistance (°C/W) specification of the external cooling device
- P_D = Device power consumption (W)
- T_A = Ambient temperature (°C)

From the first equation, the user can derive the estimated lifetime of the chip and decide if a cooling device is necessary or not. If a cooling device is to be fitted on the chip, the second equation should be used to compute the resulting average chip-junction temperature T_J in °C.

10.2. Package Drawings

10.2.1. 64 pin TQFP

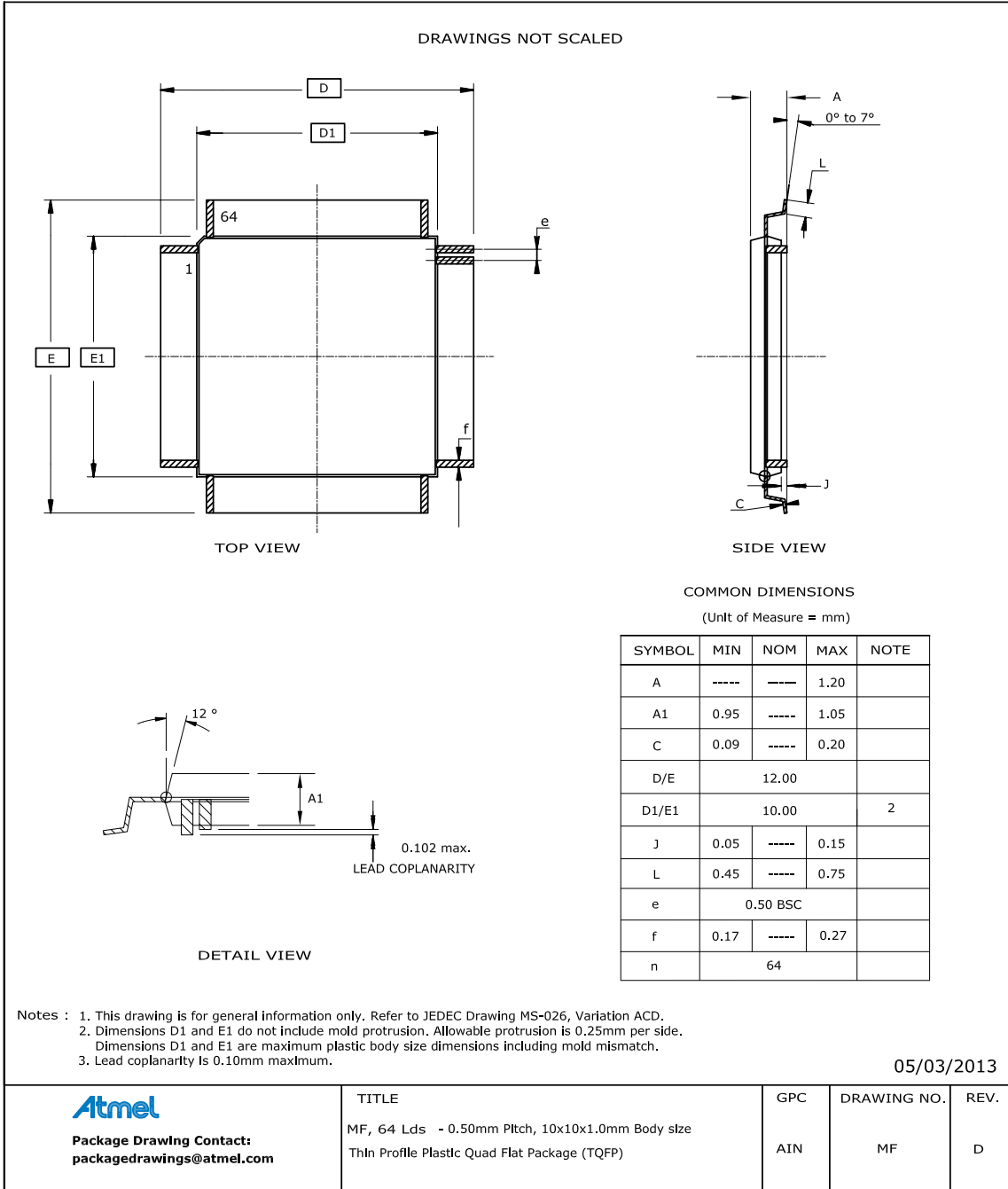

Table 10-2. Device and Package Maximum Weight

300	mg
-----	----

Table 10-3. Package Characteristics

Moisture Sensitivity Level	MSL3
----------------------------	------

Table 10-4. Package Reference

JEDEC Drawing Reference	MS-026
JESD97 Classification	E3

10.2.2. 64 pin QFN

DRAWINGS NOT SCALED

COMMON DIMENSIONS
(Unit of Measure = mm)

SYMBOL	MIN	NOM	MAX	NOTE
A	0.80	-----	1.00	
D/E	9.00 BSC			
D2/E2	4.60	4.70	4.80	
J	0.00	-----	0.05	
b	0.15	0.20	0.25	
e	0.50 BSC			
L	0.30	0.40	0.55	
N	64			

Option A Option B

Pin 1# Chamfer (C 0.35) Pin 1# Notch (0.20 R)

Notes :

- This drawing is for general information only. Refer to JEDEC Drawing MO-220, Variation VMMD-4, for proper dimensions, tolerances, datums, etc.
- Dimension b applies to metallized terminal and is measured between 0.15mm and 0.30mm from the terminal tip. If the terminal has the optical radius on the other end of the terminal, the dimension should not be measured in that radius area.

05/27/2011

<p>Package Drawing Contact: packagedrawings@atmel.com</p>	TITLE	GPC	DRAWING NO.	REV.
	PA, 64 Leads, 0.50 mm pitch, 9 x 9 x 1 mm Very Thin Quad Flat No Lead Package (VQFN) Sawn	ZST	PA	A

Note: The exposed die attach pad is not connected electrically inside the device.

Table 10-5. Device and Package Maximum Weight

200	mg
-----	----

Table 10-6. Package Characteristics

Moisture Sensitivity Level	MSL3
----------------------------	------

Table 10-7. Package Reference

JEDEC Drawing Reference	MO-220
JESD97 Classification	E3

10.2.3. 56-Ball WLCSP

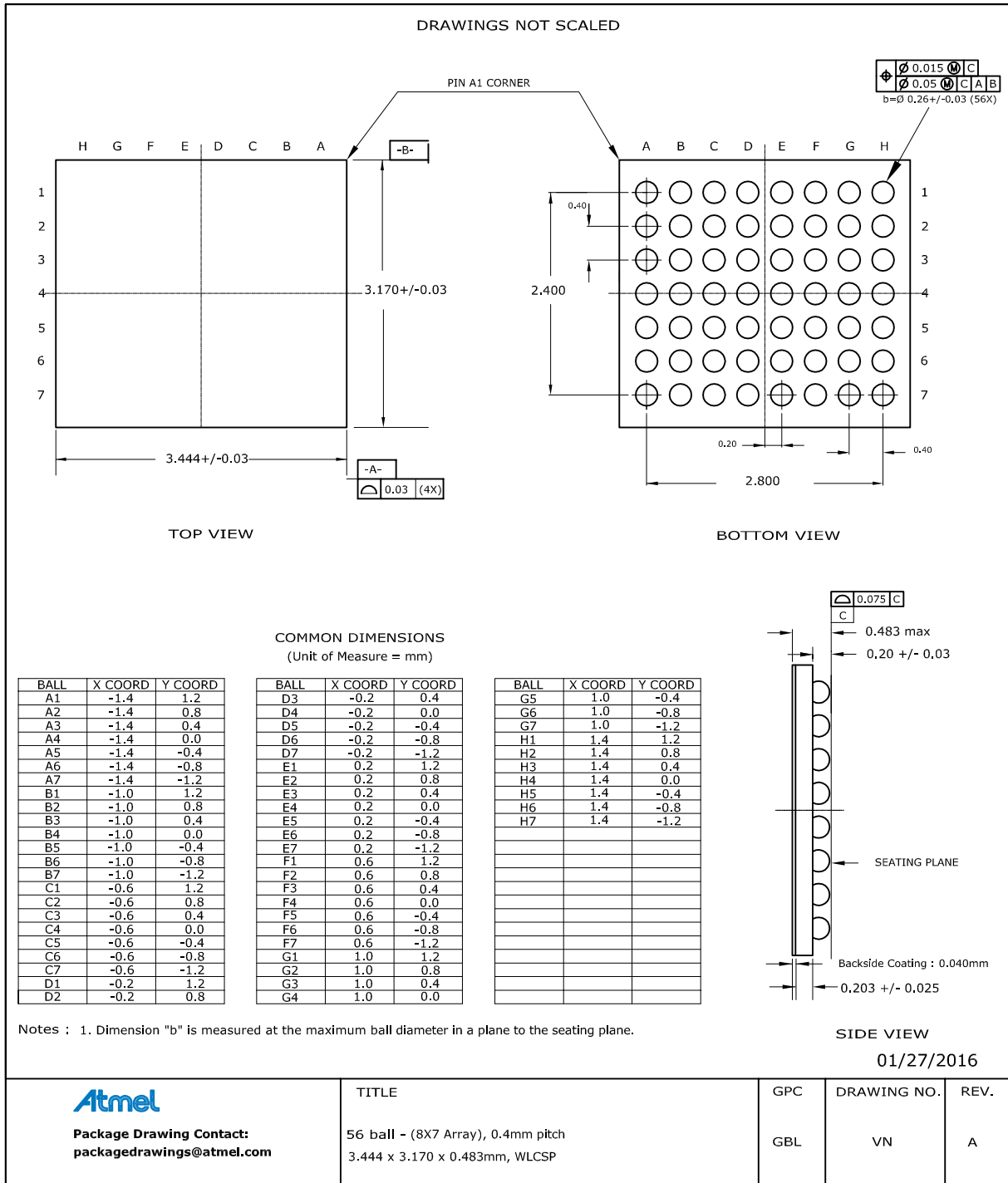

Table 10-8. Device and Package Maximum Weight

9.63	mg
------	----

Table 10-9. Package Characteristics

Moisture Sensitivity Level	MSL1
----------------------------	------

Table 10-10. Package Reference

JEDEC Drawing Reference	N/A
JESD97 Classification	e1

10.2.4. 48 pin TQFP

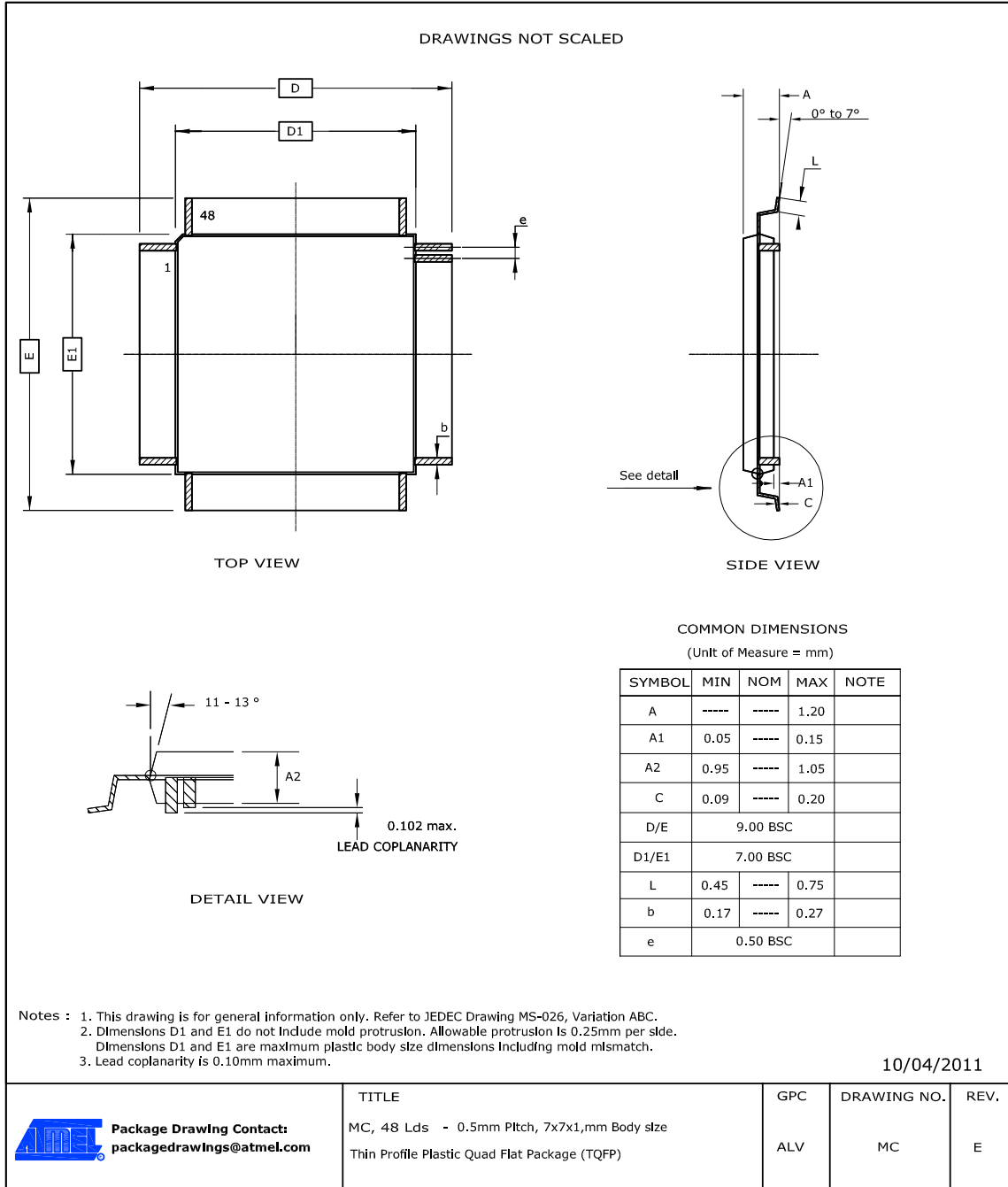

Table 10-11. Device and Package Maximum Weight

140	mg
-----	----

Table 10-12. Package Characteristics

Moisture Sensitivity Level	MSL3
----------------------------	------

Table 10-13. Package Reference

JEDEC Drawing Reference	MS-026
JESD97 Classification	E3

10.2.5. 48 pin QFN

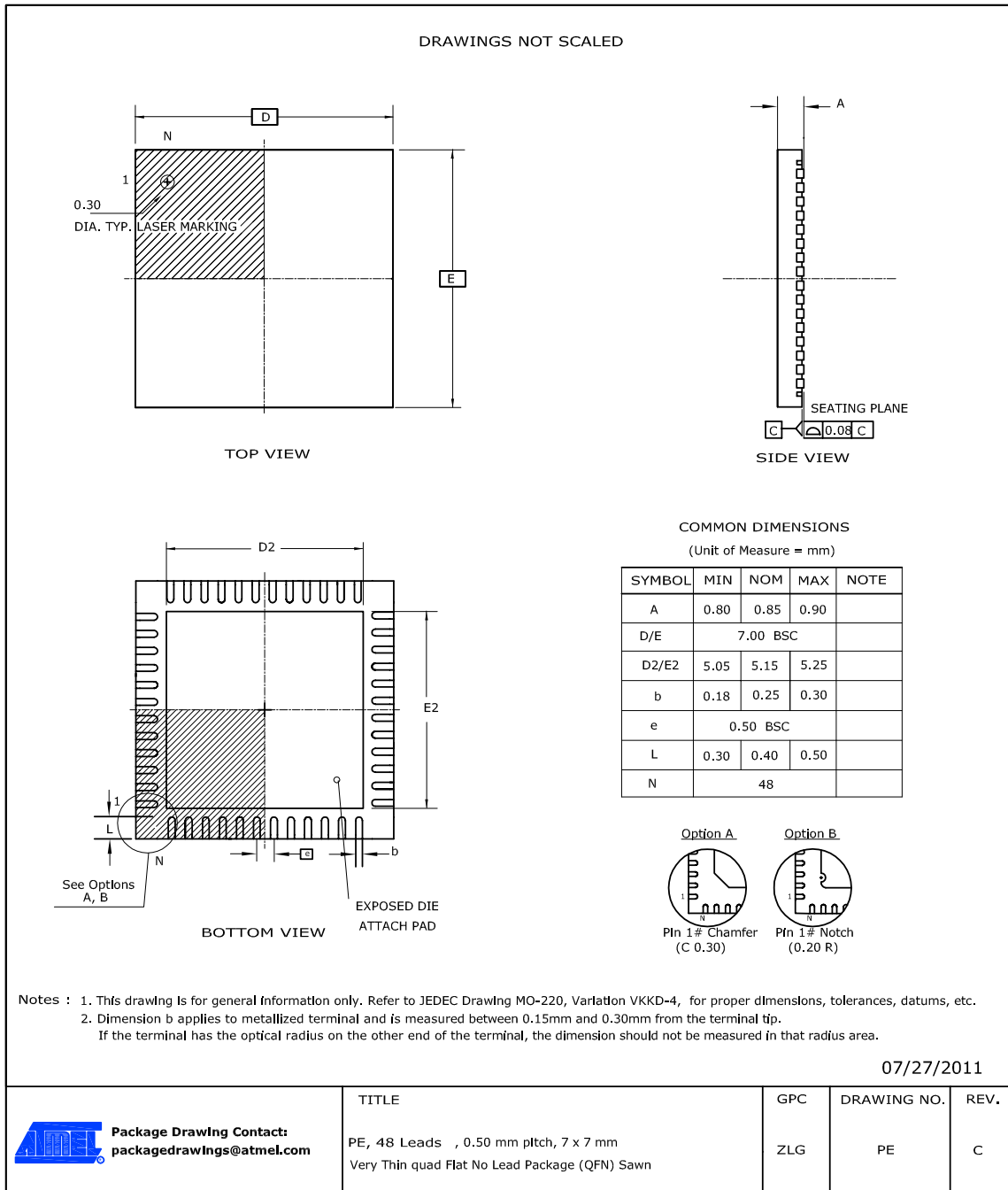

Note: The exposed die attach pad is not connected electrically inside the device.

Table 10-14. Device and Package Maximum Weight

140	mg
-----	----

Table 10-15. Package Characteristics

Moisture Sensitivity Level	MSL3
----------------------------	------

Table 10-16. Package Reference

JEDEC Drawing Reference	MO-220
JESD97 Classification	E3

10.2.6. 32 pin TQFP

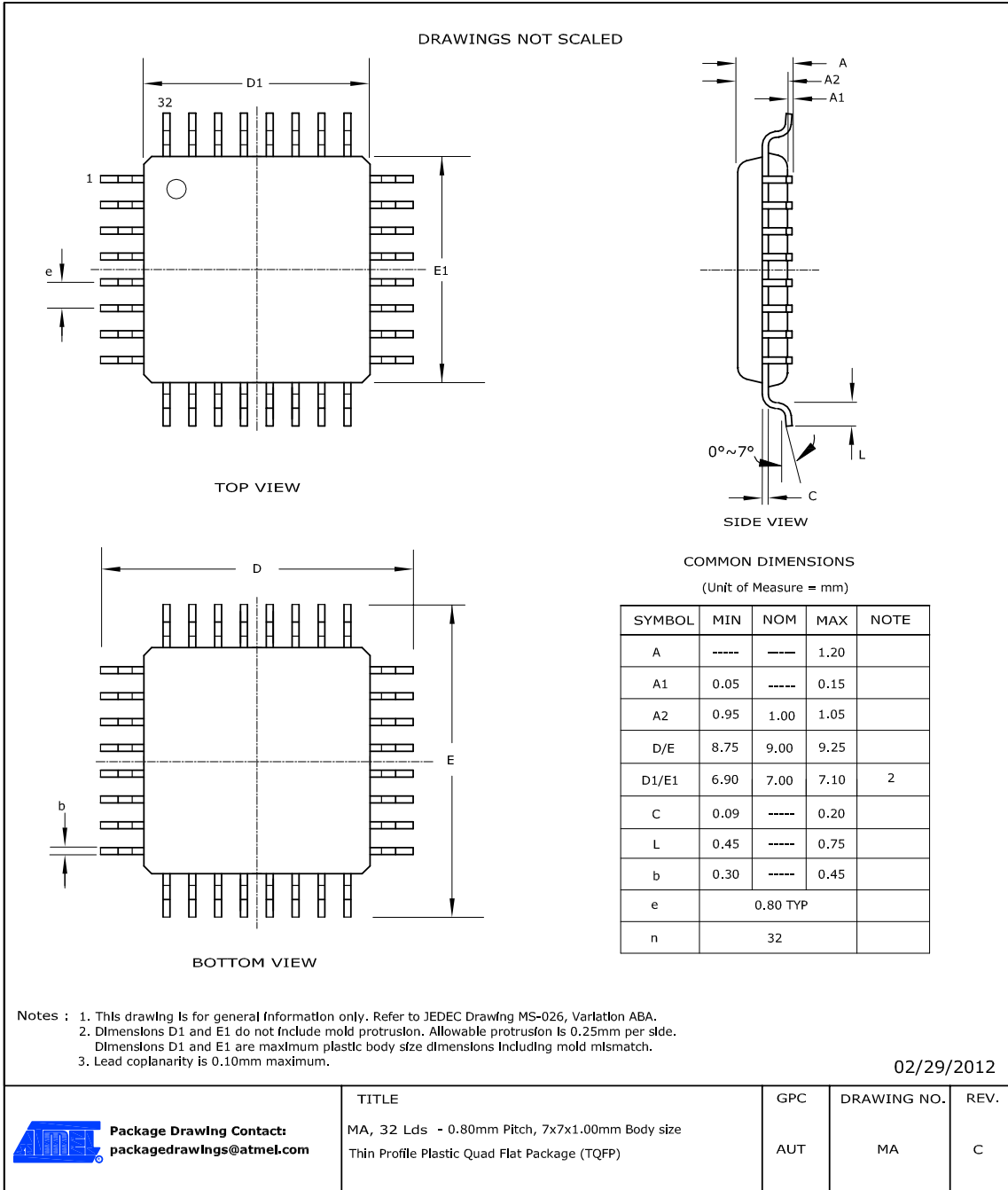

Table 10-17. Device and Package Maximum Weight

100	mg
-----	----

Table 10-18. Package Characteristics

Moisture Sensitivity Level	MSL3
----------------------------	------

Table 10-19. Package Reference

JEDEC Drawing Reference	MS-026
JESD97 Classification	E3

10.2.7. 32 pin QFN

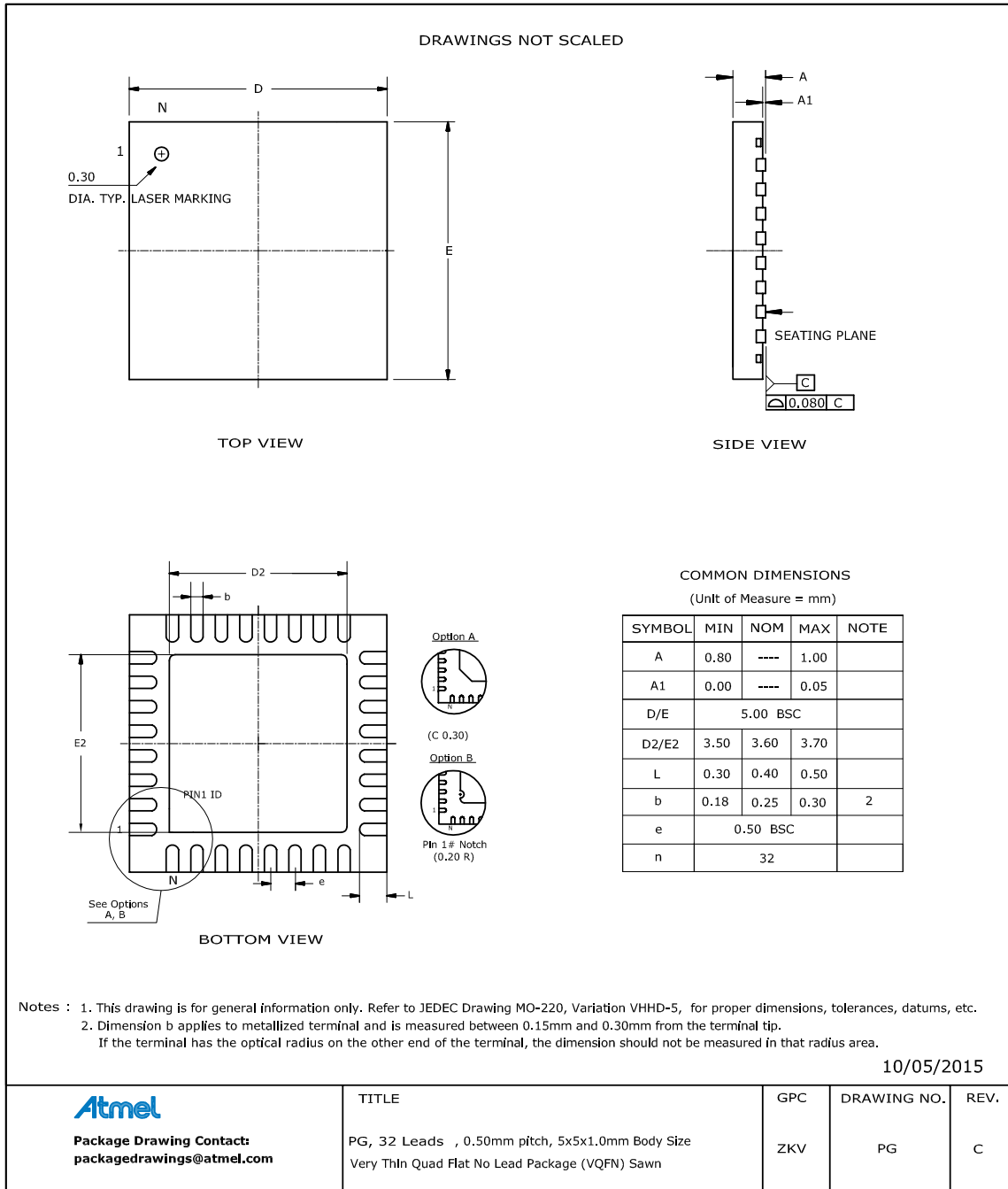

Note: The exposed die attach pad is connected inside the device to GND and GNDANA.

Table 10-20. Device and Package Maximum Weight

90	mg
----	----

Table 10-21. Package Characteristics

Moisture Sensitivity Level	MSL3
----------------------------	------

Table 10-22. Package Reference

JEDEC Drawing Reference	MO-220
JESD97 Classification	E3

10.3. Soldering Profile

The following table gives the recommended soldering profile from J-STD-20.

Table 10-23.

Profile Feature	Green Package
Average Ramp-up Rate (217°C to peak)	3°C/s max.
Preheat Temperature 175°C ±25°C	150-200°C
Time Maintained Above 217°C	60-150s
Time within 5°C of Actual Peak Temperature	30s
Peak Temperature Range	260°C
Ramp-down Rate	6°C/s max.
Time 25°C to Peak Temperature	8 minutes max.

A maximum of three reflow passes is allowed per component.



Atmel® | Enabling Unlimited Possibilities®



Atmel Corporation 1600 Technology Drive, San Jose, CA 95110 USA **T:** (+1)(408) 441.0311 **F:** (+1)(408) 436.4200 | **www.atmel.com**

© 2016 Atmel Corporation. / Rev.: Atmel-42364J-SAM-C20_Datasheet_Summary-11/2016

Atmel®, Atmel logo and combinations thereof, Enabling Unlimited Possibilities®, and others are registered trademarks or trademarks of Atmel Corporation in U.S. and other countries. ARM®, ARM Connected® logo, and others are the registered trademarks or trademarks of ARM Ltd. Other terms and product names may be trademarks of others.

DISCLAIMER: The information in this document is provided in connection with Atmel products. No license, express or implied, by estoppel or otherwise, to any intellectual property right is granted by this document or in connection with the sale of Atmel products. EXCEPT AS SET FORTH IN THE ATMEL TERMS AND CONDITIONS OF SALES LOCATED ON THE ATMEL WEBSITE, ATMEL ASSUMES NO LIABILITY WHATSOEVER AND DISCLAIMS ANY EXPRESS, IMPLIED OR STATUTORY WARRANTY RELATING TO ITS PRODUCTS INCLUDING, BUT NOT LIMITED TO, THE IMPLIED WARRANTY OF MERCHANTABILITY, FITNESS FOR A PARTICULAR PURPOSE, OR NON-INFRINGEMENT. IN NO EVENT SHALL ATMEL BE LIABLE FOR ANY DIRECT, INDIRECT, CONSEQUENTIAL, PUNITIVE, SPECIAL OR INCIDENTAL DAMAGES (INCLUDING, WITHOUT LIMITATION, DAMAGES FOR LOSS AND PROFITS, BUSINESS INTERRUPTION, OR LOSS OF INFORMATION) ARISING OUT OF THE USE OR INABILITY TO USE THIS DOCUMENT, EVEN IF ATMEL HAS BEEN ADVISED OF THE POSSIBILITY OF SUCH DAMAGES. Atmel makes no representations or warranties with respect to the accuracy or completeness of the contents of this document and reserves the right to make changes to specifications and products descriptions at any time without notice. Atmel does not make any commitment to update the information contained herein. Unless specifically provided otherwise, Atmel products are not suitable for, and shall not be used in, automotive applications. Atmel products are not intended, authorized, or warranted for use as components in applications intended to support or sustain life.

SAFETY-CRITICAL, MILITARY, AND AUTOMOTIVE APPLICATIONS DISCLAIMER: Atmel products are not designed for and will not be used in connection with any applications where the failure of such products would reasonably be expected to result in significant personal injury or death ("Safety-Critical Applications") without an Atmel officer's specific written consent. Safety-Critical Applications include, without limitation, life support devices and systems, equipment or systems for the operation of nuclear facilities and weapons systems. Atmel products are not designed nor intended for use in military or aerospace applications or environments unless specifically designated by Atmel as military-grade. Atmel products are not designed nor intended for use in automotive applications unless specifically designated by Atmel as automotive-grade.