

TOP VIEW

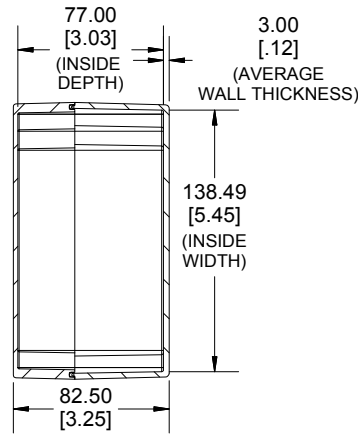

**SECTION A-A
END VIEW**

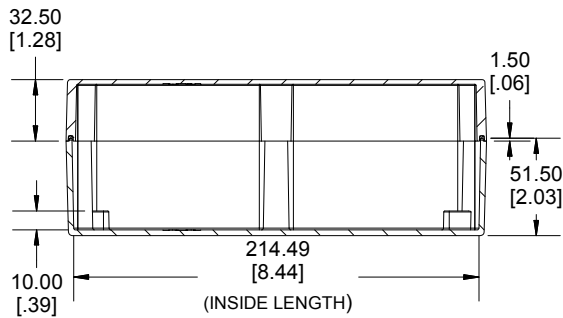

**SECTION B-B
SIDE VIEW**

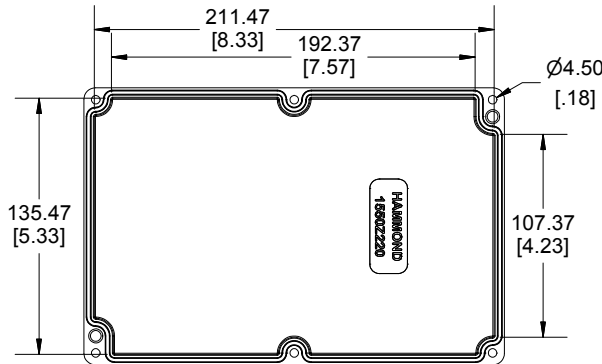

INSIDE LID

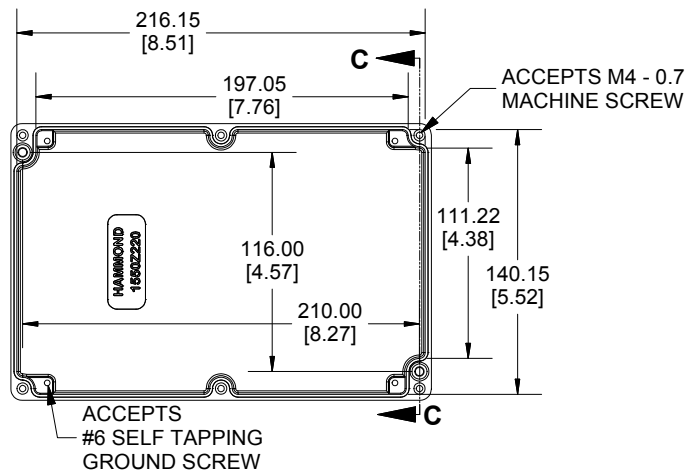

INSIDE BOX

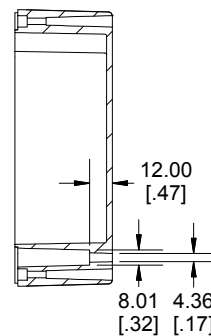

**SECTION C-C
MOUNTING HOLE**

Dimensions:
mm
[inches]



Enclosures can be Factory Modified (Milling, Drilling, Printing etc.)
Contact Factory mjm@hammondmfg.com for quotes
Solid models of this enclosure available in STEP or IGES.
(Part number and text placement/orientation on our products are subject to change,
we do not recommend using them as a locating reference for modification purposes)

NOTE	
Purchased assembly includes box, lid, silicone gasket, and 4 cover screws. Box and lid are made from Diecast Aluminum Alloy.	
Screws should not be torqued past 5-7.5 lbf.in (50 -75 cN.m)	
PART NUMBERS	
1550Z220 Enclosure	
Basic Enclosure	1550Z220
Black Enclosure	1550Z220BK
ACCESSORIES	
Pre-Formed Silicone Gasket	1550Z220GASKET

**HAMMOND
MANUFACTURING**

1550Z220
www.hammondmfg.com