

REVISIONS					
REV	ECO	DESCRIPTION	DATE	BY	APPR
A1	-	TECHNICAL DATA SHEET RELEASE	12-MAY-14	KMM	RFC

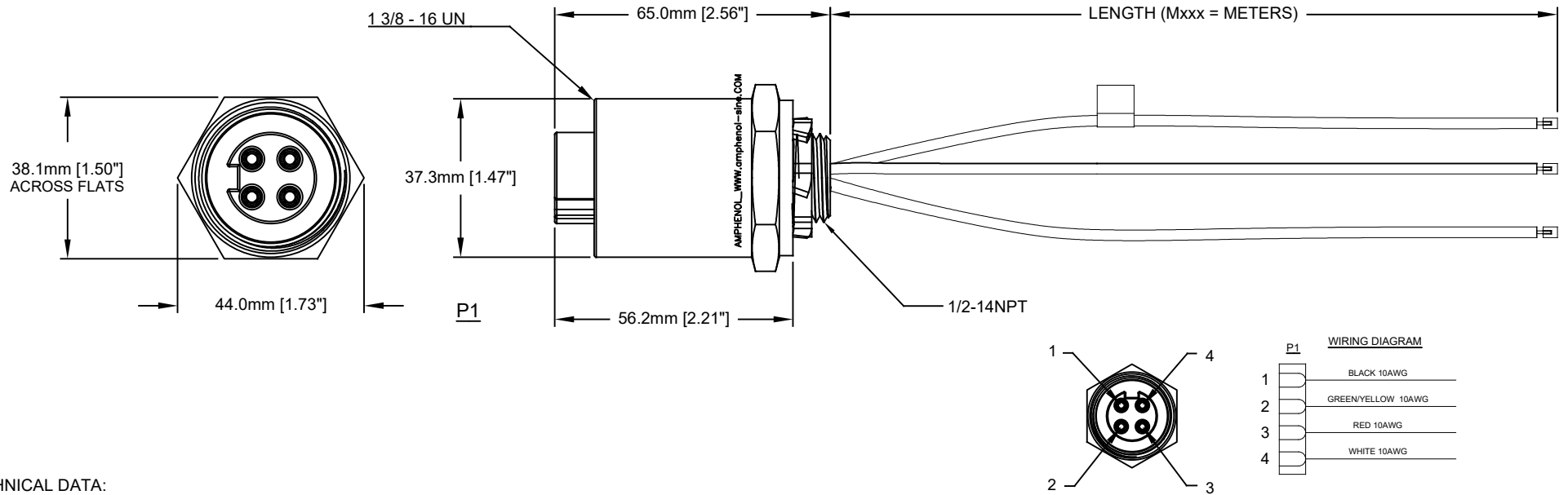

TECHNICAL DATA:

- MATERIALS:**
 HOUSING: MACHINED ALUMINUM, ANODIZED
 INSULATION INSERT: THERMOPLASTIC, UL 94/V-0
 CONTACT: GOLD FLASH PLATING OVER COPPER ALLOY
 CONDUCTOR INSULATION: PVC
 NUMBER OF CONDUCTORS: (4) 10AWG
- ELECTRICAL DATA:**
 CURRENT (MAX): 25A
 VOLTAGE (MAX): 600V AC/DC
 INSULATION RESISTANCE (MIN): 5000M OHMS
 DIELECTRIC TEST VOLTAGE: 2200V
- MECHANICAL DATA:**
 KNOCKOUT HOLE SIZE FOR PANEL MOUNT: 22.2mm [.88"]
 TEMPERATURE RANGE: -40°C TO 90°C
 PROTECTION: IP67 (MATED CONDITION)
 MATING CYCLES: >500
 VIBRATION RESISTANCE PER MIL-STD-202 METHOD 204
 THERMAL SHOCK PER MIL-STD-202 METHOD 207
 48 HOUR SALT SPRAY PER MIL-STD-202 METHOD 101
- RoHS COMPLIANT**
- UL 2237 LISTED ASSEMBLY**
 UL FILE NUMBERS: E339703

Amphenol P/N	ROCKWELL P/N	MOLEX	TURCK
P29026-M*	280-M35F-M*	CR4000A30M*	GKDF40-*M/14.5/NPT
P29026-M.5	280-M35F-M.5	CR4000A30M005	GKDF40-.5M/14.5/NPT
P29026-M1	280-M35F-M1	CR4000A30M010	GKDF40-1M/14.5/NPT
P29026-M2	280-M35F-M2	CR4000A30M020	GKDF40-2M/14.5/NPT
P29026-M3	280-M35F-M3	CR4000A30M030	GKDF40-3M/14.5/NPT

TOLERANCE	
0-2.99 M = +100.0/-25.0mm	0-9.99 FT = +4" / -1"
3-8.99 M = +150.0/-25.0mm	10.00-29.99 FT = +6" / -1"
9-14.99 M = +300.0/-25.0mm	30.00-49.99 FT = +12" / -1"
15-OVER M = +450.0/-25.0mm	50 FT-OVER = +18" / -1"

QUANTITY	PART NUMBER	DESCRIPTION	ITEM
MATERIALS LIST			
UNLESS OTHERWISE SPECIFIED		SIGNATURES	DATE
1) All dimensions are in metric (mm).		DRAWN: KMM	12-MAY-14
2) Tolerances are as follows:		CHECKED: MRF	12-MAY-14
1 PL DEC ±0.30 Fractions ±1/64		ENGINEER: KMM	
2 PL DEC ±0.15		APPROVAL: RFC	12-MAY-14
3 PL DEC ±0.08		CUSTOMER:	
3) Note reference =		THIS DRAWING IS SUPPLIED FOR INFORMATION ONLY. DESIGN FEATURES, SPECIFICATIONS AND PERFORMANCE DATA SHOWN HEREON ARE THE PROPERTY OF THE AMPHENOL CORPORATION. NO RIGHTS OF REPRODUCTION ARE IMPLIED. ALL DIMENSIONS ARE SUBJECT TO NORMAL MANUFACTURING VARIATIONS.	
MATERIAL SPECIFICATIONS:		 Sine Systems - www.amphenol-sine.com 44724 Morley Drive Clinton Township, MI 48036	
PROCESS SPECIFICATIONS:		M35 PB LITE, 4 PIN, FEMALE RECEPTACLE TRUNK, 10 AWG, 1/2 - 14NPT	
SCALE	TYPE	DWG NO.	REVISION
FULL	C-	P29026-Mxxx	A1
NEXT ASSY:		SCALE	SHEET 1 OF 1
		C-P29026	

TRN: M35 PB LITE, 4 PIN, FEMALE REC., 10AWG, 1/2-14NPT dwg no: C-P29026-Mxxx rev: A1 sh: 1 of: 1