

EPC9160: 9 V–24 V to Dual Output 5 V/ 3.3 V Synchronous Buck Converter Evaluation Board Quick Start Guide

Revision 1.0



DESCRIPTION

The EPC9160 is a 9–24 V to dual output 5 V/ 3.3 V 15 A synchronous buck converter. EPC9160 is designed with [EPC2055](#) enhancement mode eGaN® FET and LTC7890 two phase analog buck controller with integrated GaN drivers. EPC9160 features:

- Wide V_{IN} range: 9 V-24 V
- Analog controller with integrated driver optimized for eGaN® FET
- High efficiency: >93 % for 5 V output and 24 V input
- High Switching frequency (2 MHz) and small size (23 mm x 22 mm power stage)
- Reconfigurable light load operating mode and adjustable dead time
- Other functions:
 - o UVLO
 - o Over-current protection
 - o Power good output
 - o External synchronization

Table 1: Electrical Characteristics ($T_a = 25$)

Symbol	Parameter	Conditions	Min	Typ	Max	Units
V_{IN}	Input Voltage		9		24	V
$V_{IN,on, rise}$	Input UVLO turn on voltage rising edge			9		
$V_{IN,on, fall}$	Input UVLO turn on voltage falling edge			8		
I_{OUT}	Output Current	400 LFM air flow recommended			15 ^[1]	A
f_s	Switching Frequency	Mode = CCM		2000		kHz

[1] The maximum current capability is dependent on thermal conditions. The FET temperature should be monitored to ensure the maximum temperature does not exceed the rating in the datasheet, in particular when the input voltage is higher than 54 V, the maximum output current will be reduced.

REGULATORY INFORMATION

This power module is for evaluation purposes only. It is not a full-featured power module and cannot be used in final products. No EMI test was conducted. It is not FCC approved.

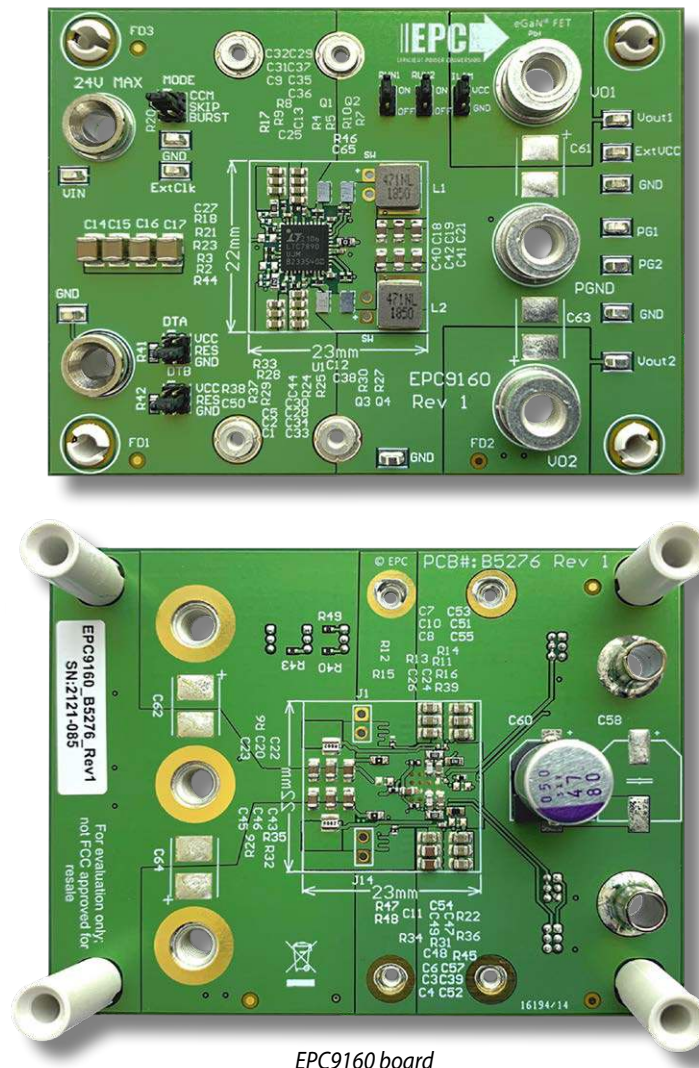

QUICK START PROCEDURE

The demonstration board EPC9160 is easy to set up to evaluate the performance of the EPC2055 eGaN FETs and directly drive from the controller IC. Refer to figure 1 for proper connect and measurement setup and follow the procedure below:

1. Check if the jumpers are at its default location as shown in figure 1.
2. With power off, connect the input power supply between V_{IN} (J9) and GND (J10) banana jacks as shown. A shunt can be inserted to measure input current.
3. With power off, connect a programmable load as needed between V_{out1} and/or V_{out2} (J4 and J8) and GND (J18) as shown in figure 1.
Note: Initial no load.
4. Turn on the supply voltage beyond UVLO to the required value. The applied voltage should not exceed 24 V under any conditions.
5. Check the output voltages are regulated to 5 V and 3.3 V respectively and switching at no-load. If output voltage is not observed, please carefully re-examine the circuit connections.
6. Activate the programmable load and set to the desired current ensuring the current does not exceed the maximum ratings.
7. Once operational, adjust the bus voltage and load current within the allowed operating range and observe the output switching behavior, efficiency and other parameters as desired.
8. For measuring switch node waveforms, please use J1 and J14 without any ground lead to the scope. **Please note polarity.**
9. For shutdown, please follow steps in reverse of step 1-5. For custom configuration please refer the optional configuration section.

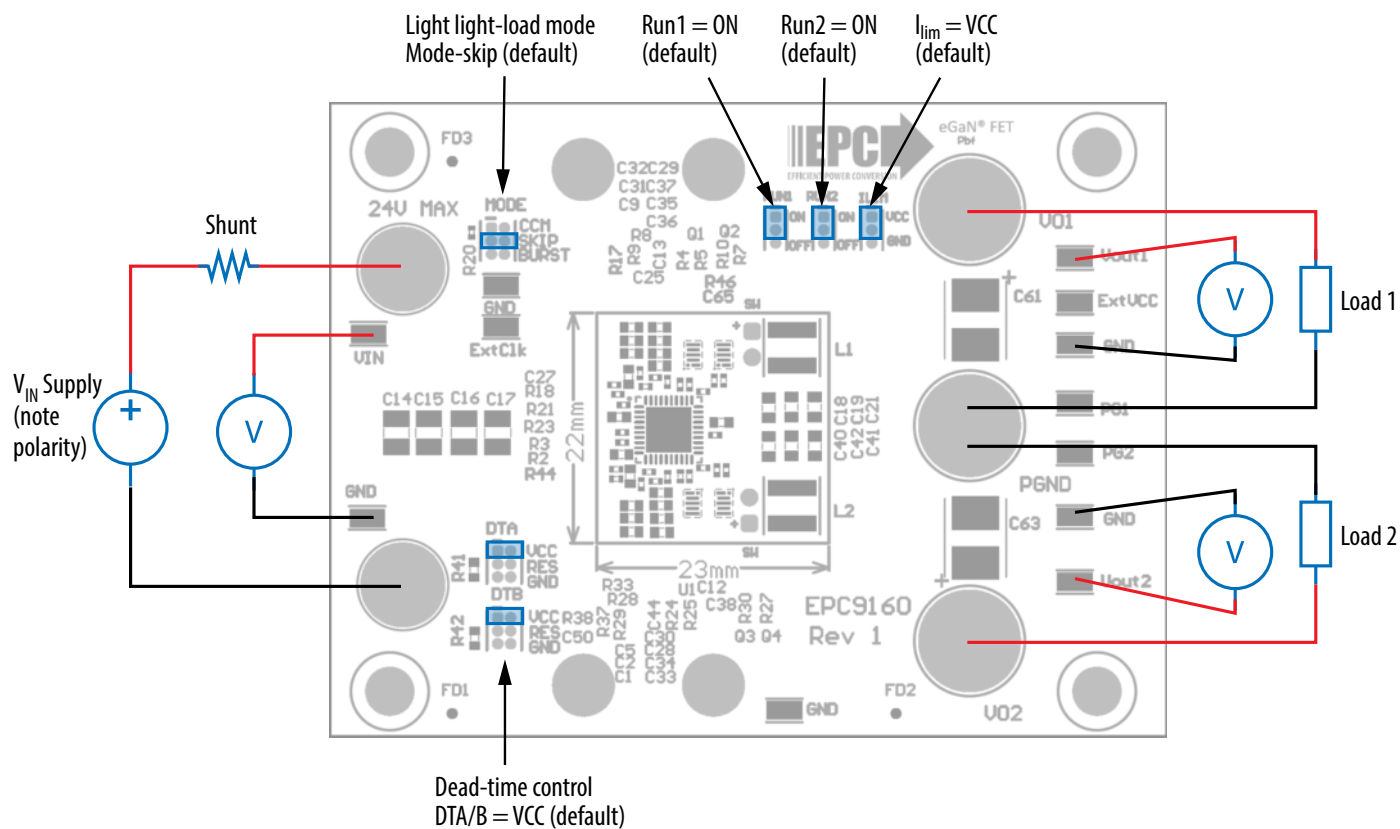

Figure 1: Proper connection set up and default jumper positions

EXPERIMENTAL RESULTS

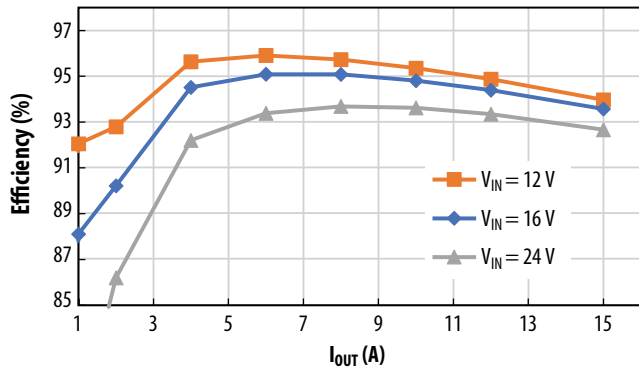

Figure 2a: Typical efficiency and power losses for phase 1: $V_{o1} = 5$ V (mode = skip, DTA/B = VCC, V_{o1} is ON, V_{o2} is OFF)

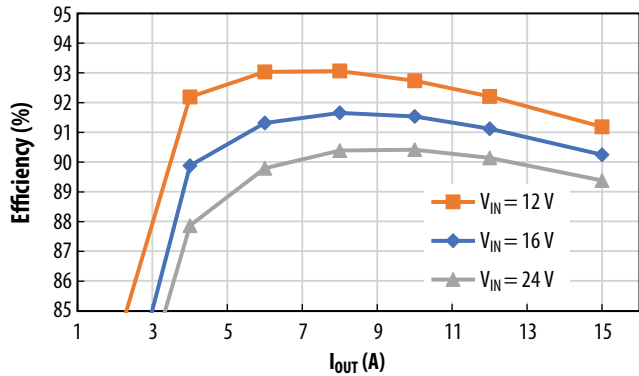
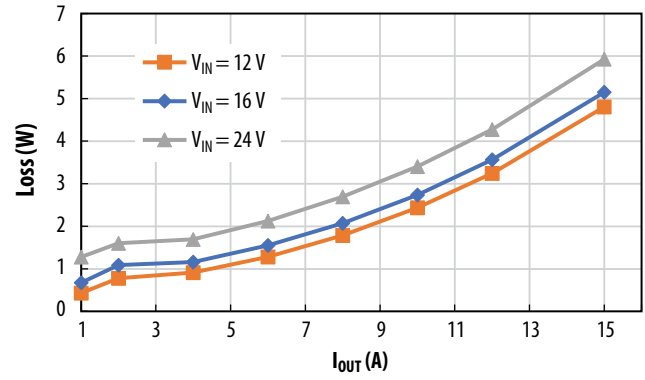
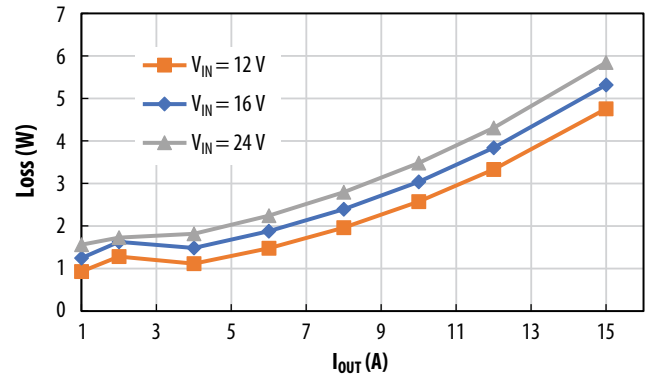

Figure 2b: Typical efficiency and power losses for phase 2: $V_{o2} = 3.3$ V (mode = skip, DTA/B = VCC, both phase is ON)



Typical load transient response

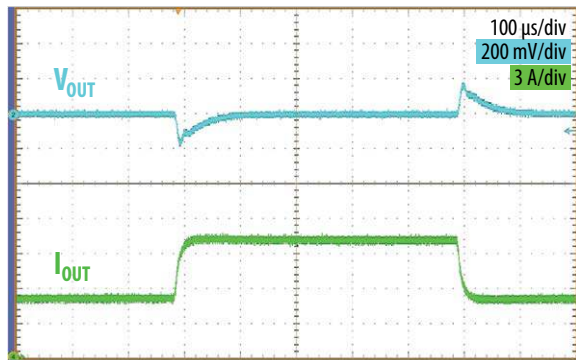

Figure 3: Typical load transient response: $V_{IN} = 24$ V, $V_{o2} = 3.3$ V, 5 A to 10 A load step, $di/dt = 0.5$ A/ μ s

Startup waveform

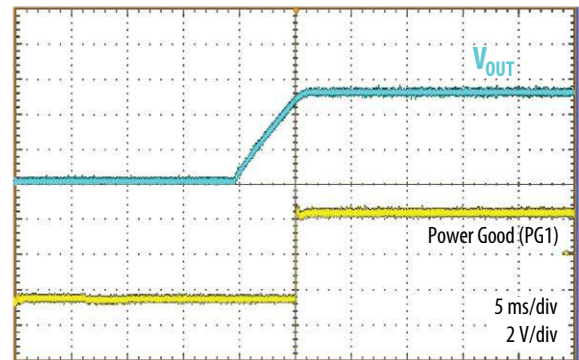

Figure 4: Startup waveform: $V_{IN} = 24$ V, $V_{OUT1} = 5$ V ($I_{lim} = VCC$)

Typical load regulation

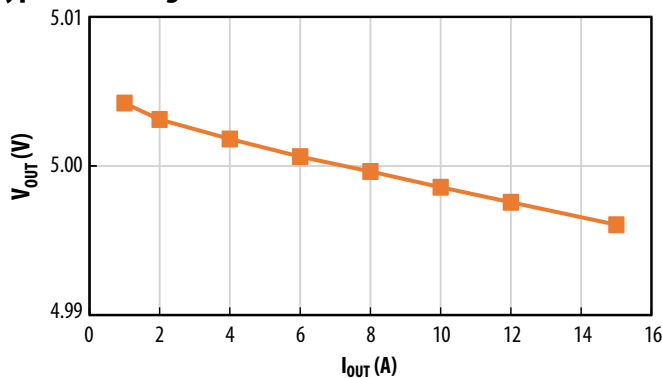

Figure 5a: Typical load regulation: $V_{IN} = 24$ V, $V_{OUT1} = 5$ V

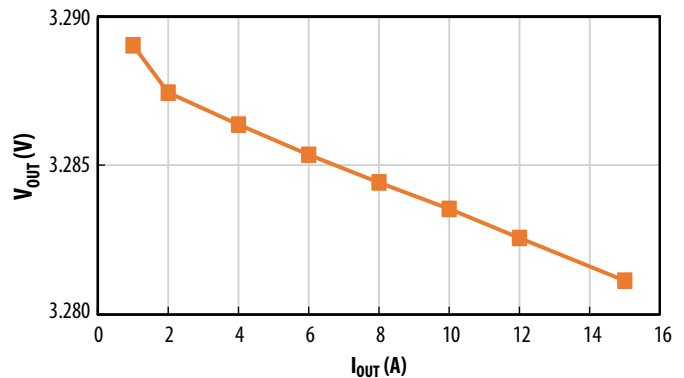

Figure 5b Typical load regulation: $V_{IN} = 24$ V, $V_{OUT2} = 3.3$ V

Thermal performance

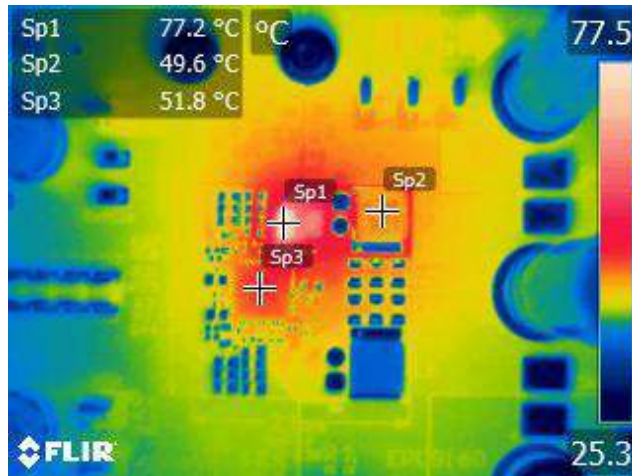

Figure 6: $V_{IN} = 24\text{ V}$, $V_{OUT2} = 3.3\text{ V}$, $I_{OUT} = 10\text{ A}$, No forced air flow (natural convection)

CUSTOM CIRCUIT CONFIGURATIONS

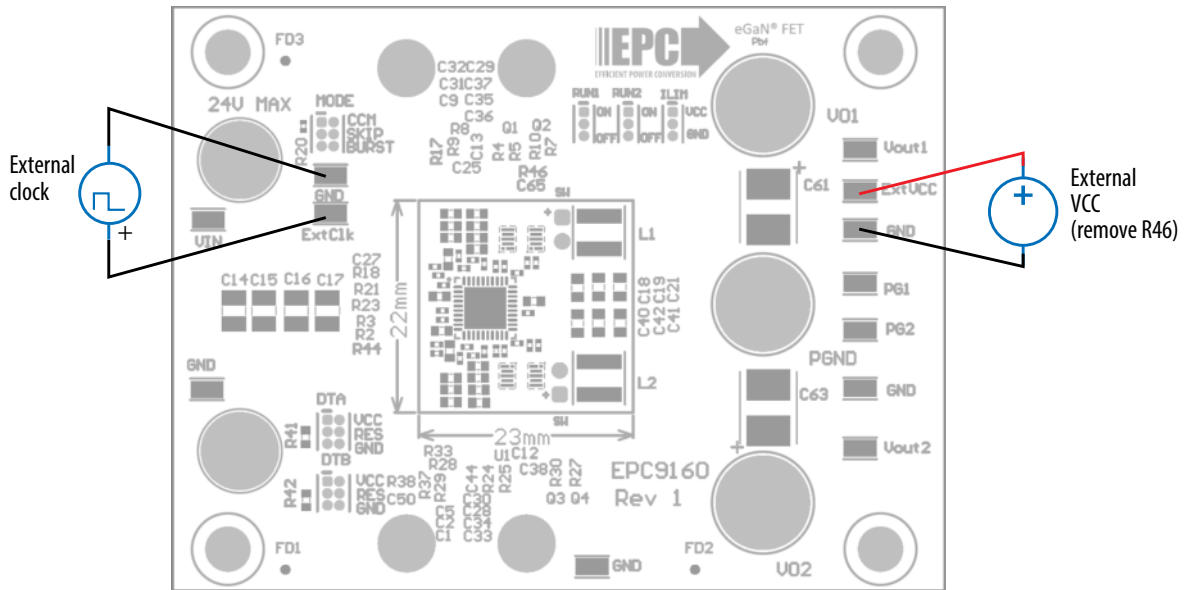

Figure 7: An example custom circuit connection with external VCC and clock

Input UVLO adjustment

The V_{IN} UVLO threshold voltage can be set by R48 and R49. If needed, a UVLO voltage can be set by changing R48 and R49: Please refer to LTC7890 datasheet for more information.

$$UVLO_{rising} = 1.2\text{ V} \left(1 + \frac{R48}{R49} \right)$$

$$UVLO_{falling} = 1.1\text{ V} \left(1 + \frac{R48}{R49} \right)$$

Switching frequency adjustment

If needed, switching frequency can be modified by changing the value of R21. Please refer to LTC7890 datasheet for more information.

$$f_s (\text{MHz}) \approx \frac{37 (\text{MHz})}{R21 (\text{k}\Omega)}$$

External VCC

While the chip can be solely powered by the main power supply V_{IN} , the losses may be high for high input voltage. By default, Ext VCC is connected to phase 1 output ($R46 = 0 \Omega$). The user can also connect an external power supply (for e.g. 5 V) to Ext VCC (TP6) and GND as shown in figure 7 and test phase 2 only. Please remove R46 before doing so. Please refer to LTC7890 datasheet for more information.

Deadtime adjustment

Dead time control is important for eGaN FETs, particularly at high frequencies and high current applications. The dead time is controlled by the resistance values of R41 and R42 for rising and falling edges respectively. Additionally, Jumper J21 and J13 can be used to enable adaptive and fixed dead time control as supported by the LTC7890 controller. Please refer to LTC7890 datasheet for more information.

External clock synchronization

Some system requires power supplies be synchronized. The user may install jumper R23, and an external clock can be connected to synchronize the PWM to an external clock as shown in figure 7. Please refer to the datasheet of LTC7890 for more details.

THERMAL MECHANICAL DRAWINGS

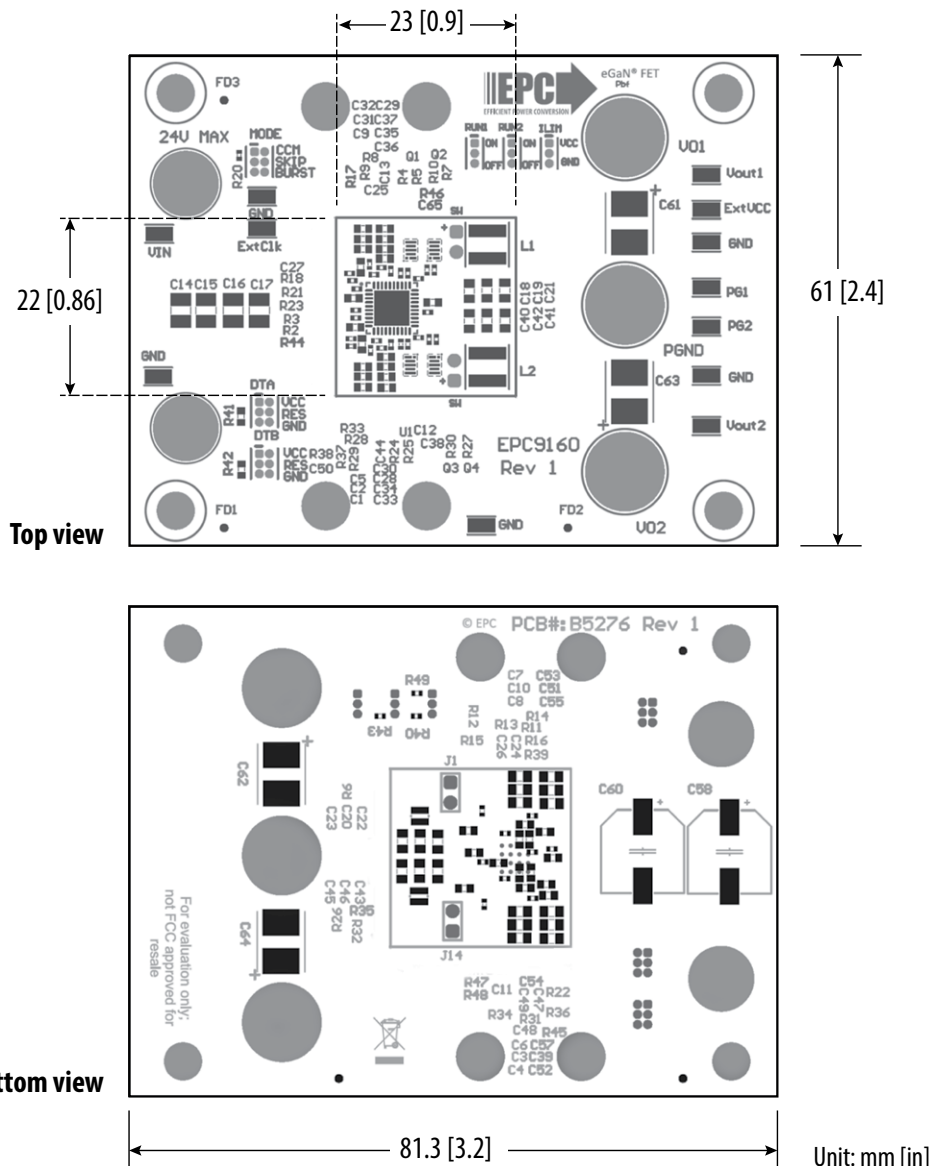

Figure 9: Mechanical dimensions

THERMAL MANAGEMENT (optional)

The EPC9160 is intended for bench evaluation at room temperature with forced air convection cooling. A heatsink is not required but will significantly improve convective heat dissipation from the topside of the FET and increase the current capacity of these devices.

The EPC9160 board is equipped with four mechanical SMD spacers that can be used to easily attach a standard eighth-brick converter heatsink using standard M2 screws (See Figure 10). Thermal interface material (TIM) pads (2x) are required for good thermal conductance between the FETs and the heatsink bottom surface. See Figure 10 for minimum required TIM pad size.

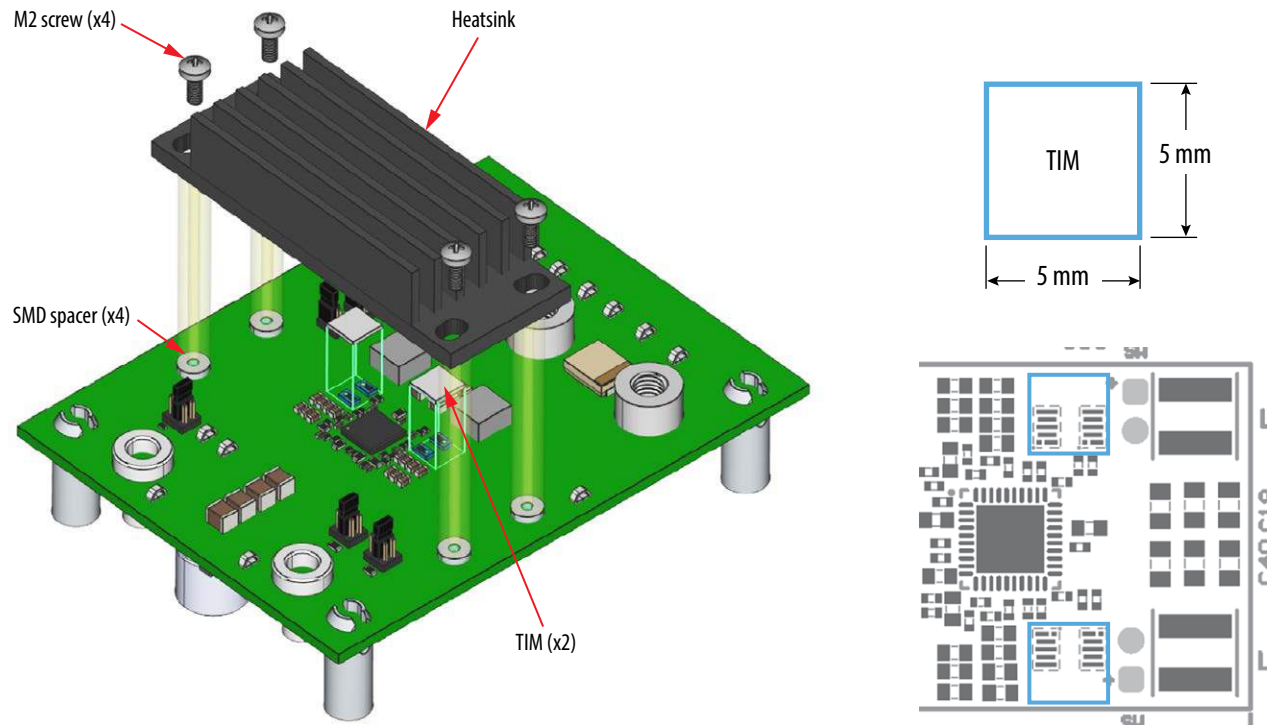

Figure 10: Exploded 3D assembly of heat sink installment and locations of TIM material

The following heat sink is recommended for EPC9160:

- **Wakefield** P/N : 567-45AB

A TIM is required between the FETs and the heatsink. The choice of TIM needs to consider the following characteristics.

- **Mechanical compliance** – During the attachment of the heat spreader, the TIM underneath is compressed from its original thickness to the vertical gap distance between the spacers and the FETs. This volume compression exerts a force on the FETs. A maximum compression of 2:1 is recommended for maximum thermal performance and to constrain the mechanical force which maximizes thermal mechanical reliability.
- **Electrical insulation** – The backside of the eGaN FET is a silicon substrate that is connected to source and thus the upper FET in a half-bridge configuration is connected to the switch-node. To prevent short-circuiting the switch-node to the grounded thermal solution, the TIM must be of high dielectric strength to provide adequate electrical insulation in addition to its thermal properties.
- **Thermal performance** – The choice of thermal interface material will affect the thermal performance of the thermal solution. Higher thermal conductivity materials is preferred to provide higher thermal conductance at the interface.

EPC recommends the following thermal interface materials (TIM) for EPC9160:

- **t-Global** P/N: TG-A1780 x 0.5 mm (highest conductivity of 17.8 W/m·K)
- **t-Global** P/N: TG-A6200 x 0.5 mm (moderate conductivity of 6.2 W/m·K)

NOTE. The EPC9160 development board does not have any current or thermal protection on board. For more information regarding the thermal performance of EPC eGaN FETs, please consult: D. Reusch and J. Glaser, *DC-DC Converter Handbook, a supplement to GaN Transistors for Efficient Power Conversion*, First Edition, Power Conversion Publications, 2015.

Table 2: Bill of Materials

Item	Qty	Reference	Part Description	Manufacturer	Part #
1	13	C1, C2, C9, C28, C29, C30, C31, C32, C33, C34, C35, C36, C37	CAP CER 1 µF 50 V X7R 0603	Taiyo Yuden	UMK107AB7105KA-T
2	2	C3, C4	CAP CER 1 µF 100 V X7S 0805	TDK	C2012X7S2A105K125AB
3	1	C5	CAP CER 0.22 µF 100 V X7S 0603	Taiyo Yuden	HMK107C7224KAHTE
4	10	C6, C7, C8, C10, C39, C51, C52, C53, C55, C57	CAP CER 2.2 µF 50 V X5R 0805	Samsung	CL21A225KB9LNNC
5	1	C11	CAP CER 4.7 µF 16 V X5R 0603	TDK	C1608X5R1C475K080AC
6	2	C12, C38	CAP CER 0.1 µF 25 V X7R 0402	TDK	C1005X7R1E104K050BB
7	2	C13, C44	CAP CER 0.1 µF 25 V X5R 0402	TDK	C1005X5R1E104K050BC
8	4	C14, C15, C16, C17	CAP CER 10 µF 100 V X7S 1210	Murata	GRM32EC72A106KE05L
9	12	C18, C19, C20, C21, C22, C23, C40, C41, C42, C43, C45, C46	CAP CER 22 µF 16 V X5R 0805	TDK	C2012X5R1C226K125AC
10	2	C24, C47	CAP CER 0.022 µF 25 V X7R 0603	KEMET	C0603C223K3RACTU
11	2	C25, C48	CAP CER 470 pF 50 V X7R 0402	KEMET	C0402C471J5RACTU
12	2	C26, C49	CAP CER 100 pF 50 V C0G/NP0 0603	AVX	06035A101FAT2A
13	1	C58	CAP ALUM 47 µF 20% 80 V SMD	Panasonic	80SXV47M
14	1	C60	CAP ALUM 47 µF 20% 80 V SMD	Panasonic	80SXV47M
15	4	C61, C62, C63, C64	CAP TANT POLY 100 µF 35 V 2924	KEMET	T523H107M035APE070
16	1	C65	CAP CER 1 µF 16 V X5R 0402	TDK	C1005X5R1C105K050BC
17	3	J3, J19, J23	Header Male 50 mil 1 row, 3 pos., Thru Vert.	Sullins Connector Solutions	GRPB031VWVN-RC
18	3	J4, J8, J18	M5 high current SMD terminal	Würth	7466005R
19	2	J9, J10	PCB Banana Female 1 row, 1 pos., Thru Vert.	Keystone	575-8
20	3	J13, J21, J22	Header Male 50 mil 2 row, 3 pos., Thru Vert.	Sullins	GRPB032VWVN-RC
21	2	J9, J10	PCB Banana Female 1 row, 1 pos., Thru Vert.	Keystone	575-8
22	3	J13, J21, J22	Header Male 50 mil 2 row, 3 pos., Thru Vert.	Sullins	GRPB032VWVN-RC
23	6	JP1, JP2, JP3, JP4, JP5, JP6	50 mil Jumper Black with Handle	Harwin Inc	M50-2000005
24	2	L1, L2	0.47 µH, 18.4A, ±20%, DCR=4.13 mΩ	Pulse	PM2203.471NLT
25	4	Q1, Q2, Q3, Q4	40 V 29 A 3.6 mΩ	EPC	EPC2055
26	16	R2, R3, R4, R5, R7, R9, R10, R24, R25, R27, R28, R29, R30, R40, R43	RES SMD 0 Ω JUMPER 1/10 W 0402	Panasonic	ERJ-2GE0R00X
27	2	R6, R26	RES 0.002 Ω 1 W 0805 WIDE	Susumu	KRL2012E-M-R002-G-T5
28	2	R11, R31	RES SMD 1K Ω 0.1% 1/10 W 0603	Yageo	RT0603BRD071KL
29	2	R13, R34	RES SMD 10 K Ω 5% 1/16 W 0402	Yageo	RC0402JR-0710KL
30	2	R15, R35	RES SMD 10 Ω 1% 1/10 W 0603	Panasonic	ERJ-3EKF10R0V
31	1	R16	RES SMD 105K Ω 0.1% 1/10 W 0603	Panasonic	ERA-3AEB1053V
32	1	R17	RES 20 K Ω 0.1% 1/10 W 0603	Stackpole	RNCF0603BTE20K0
33	1	R20	RES SMD 100 K Ω 1% 1/16 W 0402	Yageo	RT0402FRE07100KL
34	1	R21	RES SMD 18 K Ω 0.1% 1/16 W 0402	Panasonic	ERA-2AEB183X
35	1	R36	RES SMD 75 K Ω 0.1% 1/10 W 0603	Yageo	RT0603BRD0775KL
36	1	R37	RES SMD 24 K Ω 0.1% 1/10 W 0603	Panasonic	ERA-3APB243V
37	1	R39	RES SMD 10 K Ω 1% 1/10 W 0402	Panasonic	ERJ-2RKF1002X
38	1	R41	RES SMD 4.64K Ω 0.1% 1/10 W 0603	Yageo	RT0603BRD074K64L
39	1	R48	RES SMD 1 M Ω 1% 1/16 W 0402	Yageo	RC0402FR-071ML
40	1	R42	RES SMD 6.2K Ω 0.1% 1/10 W 0603	Yageo	RT0603BRE076K2L
41	1	R46	RES SMD 0 Ω JUMPER 1/10 W 0603	Panasonic	ERJ-3GEY0R00V
42	1	R48	RES SMD 1 M Ω 1% 1/16 W 0402	Yageo	RC0402FR-071ML
43	1	R49	RES SMD 150 K Ω 1% 1/16 W 0402	Yageo	RC0402FR-07150KL
44	4	SO1, SO2, SO3, SO4	BRD SPT SNAP FIT SCREW MNT 5/8"	Keystone	8834
45	4	SO5, SO6, SO7, SO8	Round Standoff Threaded M2x0.4 Steel 0.039" (1.00 mm)	Würth	9774010243R
46	12	TP1, TP2, TP3, TP4, TP5, TP6, TP7, TP8, TP9, TP10, TP11, TP12	HookUP SMD	Keystone	5015
47	1	U1	Analog controller	Analog Devices	LTC7890
48	1	R8	RES SMD 100 Ω 1% 1/10 W 0402	Yageo	RC0402FR-07100RL

Table 3: Optional Components

Item	Qty	Reference	Part Description	Manufacturer	Part #
1	2	D1, D2	DIODE SCHOTTKY 100V 2A DO220AA	Vishay	SS2PH10-M3
2	1	R23	RES SMD 0 Ω JUMPER 1/10 W 0603	Panasonic	ERJ-3GEY0R00V

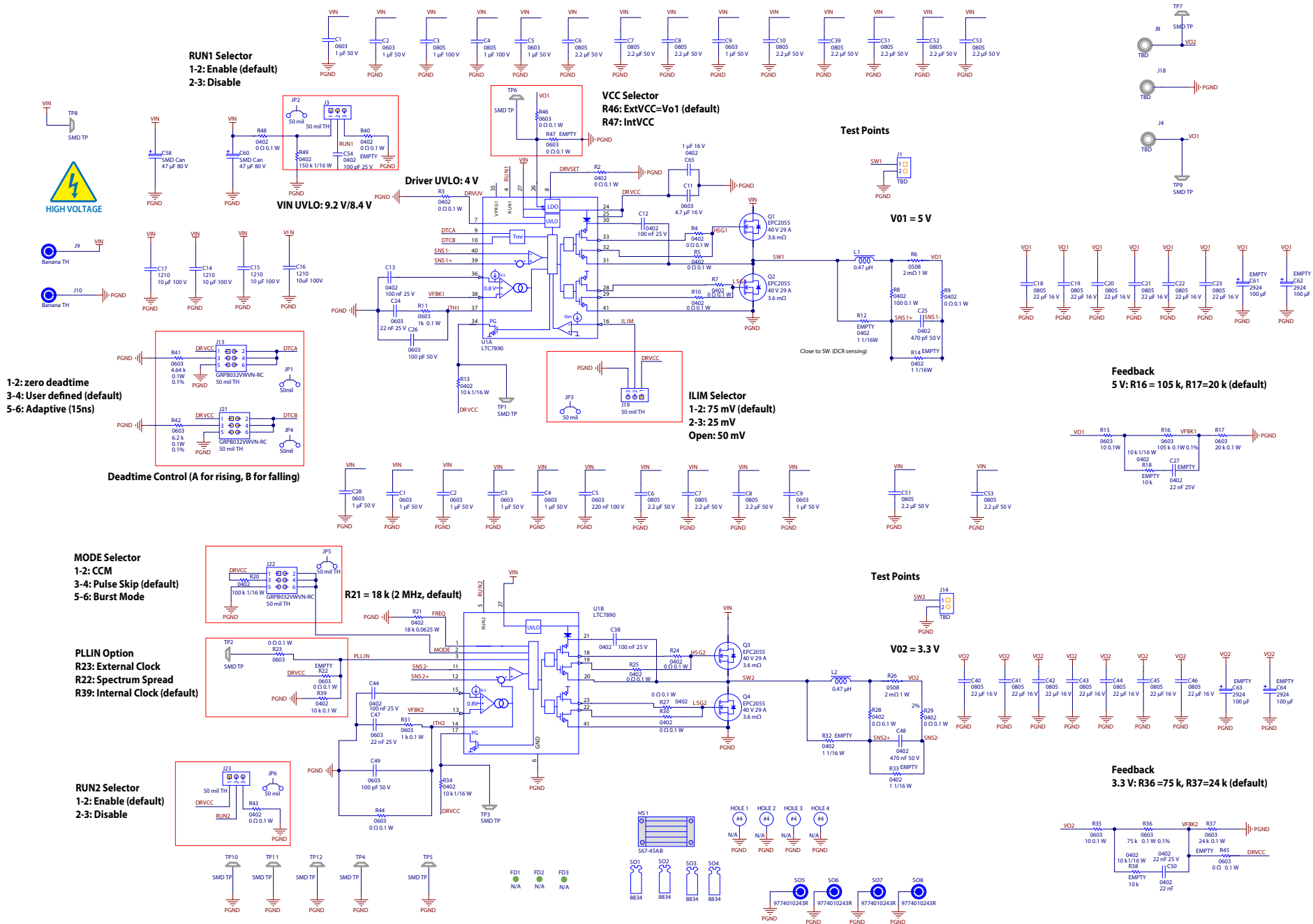

Figure 10: EPC9160 schematic

For More Information:

Please contact info@epc-co.com
or your local sales representative

Visit our website:
www.epc-co.com

Sign-up to receive
EPC updates at
bit.ly/EPCupdates
or text "EPC" to 22828



EPC Products are distributed through Digi-Key.
www.digikey.com

Demonstration Board Notification

The EPC9160 board is intended for product evaluation purposes only. It is not intended for commercial use nor is it FCC approved for resale. Replace components on the Evaluation Board only with those parts shown on the parts list (or Bill of Materials) in the Quick Start Guide. Contact an authorized EPC representative with any questions. This board is intended to be used by certified professionals, in a lab environment, following proper safety procedures. Use at your own risk.

As an evaluation tool, this board is not designed for compliance with the European Union directive on electromagnetic compatibility or any other such directives or regulations. As board builds are at times subject to product availability, it is possible that boards may contain components or assembly materials that are not RoHS compliant. Efficient Power Conversion Corporation (EPC) makes no guarantee that the purchased board is 100% RoHS compliant.

The Evaluation board (or kit) is for demonstration purposes only and neither the Board nor this Quick Start Guide constitute a sales contract or create any kind of warranty, whether express or implied, as to the applications or products involved.

Disclaimer: EPC reserves the right at any time, without notice, to make changes to any products described herein to improve reliability, function, or design. EPC does not assume any liability arising out of the application or use of any product or circuit described herein; neither does it convey any license under its patent rights, or other intellectual property whatsoever, nor the rights of others.