

TERMINALS
IN CHAIN FORM
SCALE 1:1

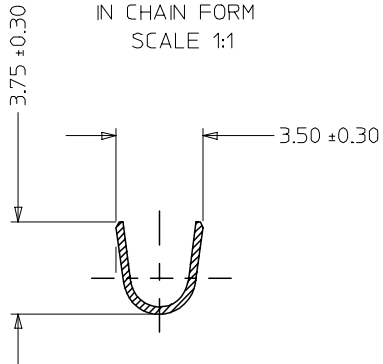

SECTION Y-Y 5:1
WIRE CRIMP AREA

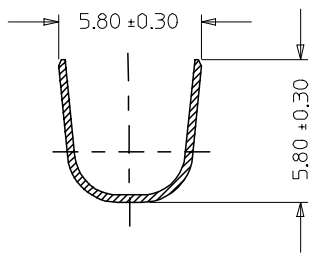

SECTION Z-Z 5:1
INSULATION CRIMP AREA

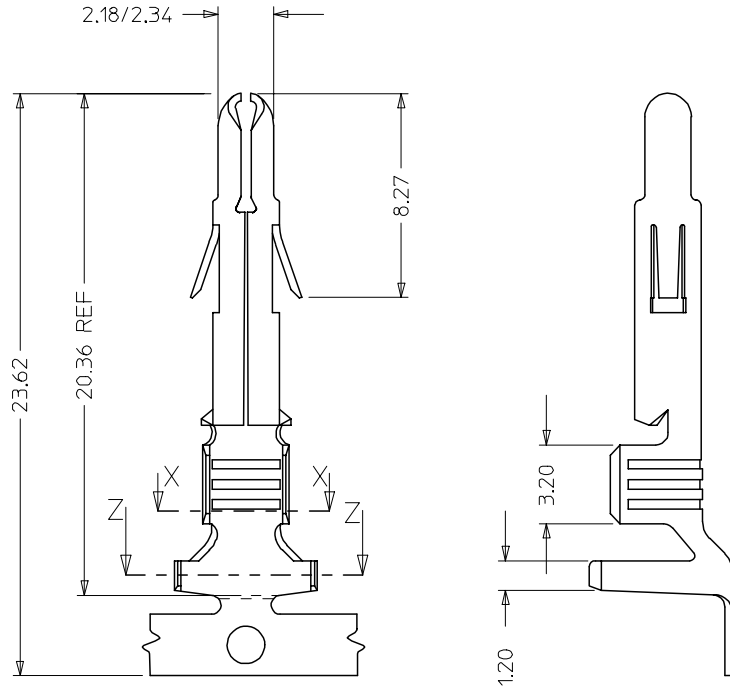
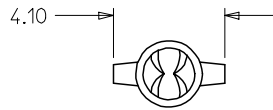

MATERIAL NO.	FINISH	WIRE SIZE	INSULATION DIA	PACKAGING METHOD
36536-0001	SEE NOTE 2	#16-13 AWG	5.10 MAX	CHAIN
36536-0002	SEE NOTE 2	#16-13 AWG	5.10 MAX	LOOSE

NOTES:

- 1) MATERIAL: BRASS
- 2) FINISH: HOT TIN DIP, THICKNESS=0.51 MICROMETER
- 3) PIN TERMINALS FOR USE WITH THE 0.084/(2.13) SERIES HOUSINGS
PLUG (42021-**) CAP (42022-**)
- 4) CRIMP RANGE SEE CHART
- 5) PRODUCT SPECIFICATION PS-42022-0001 APPLIES

ENTER DESCRIPTION EC NO: 12005-0019 DRAWN: SSUDHIR 2004/07/07 CHKD: DGDATHA 2004/07/07 APPR: DGDATHA 2004/07/08	QUALITY SYMBOLS 	GENERAL TOLERANCES (UNLESS SPECIFIED)		SCALE 5:1	DESIGN UNITS METRIC	THIRD ANGLE PROJECTION	REVISE ON CAD ONLY		
				DIMENSION STYLE MM ONLY		TITLE TERMINAL SPLIT PIN MLX #13-16 AWG 5.08 INS DIA			
		4 PLACES ± --- ± --- 3 PLACES ± --- ± --- 2 PLACES ± 0.25 ± --- 1 PLACE ± 0.38 ± ---	ANGULAR ± 2 °		DRAWN BY SSUDHIR	DATE 2004/05/24	MOLEX INCORPORATED		
		DRAFT WHERE APPLICABLE MUST REMAIN WITHIN DIMENSIONS		APPROVED BY DGDATHA	DATE 2004/05/24	MATERIAL NO. SEE CHART	DOCUMENT NO. SD-36536-001	SHEET NO. 1 OF 1	
REV B1				THIS DRAWING CONTAINS INFORMATION THAT IS PROPRIETARY TO MOLEX INCORPORATED AND SHOULD NOT BE USED WITHOUT WRITTEN PERMISSION			A3		