

### Description

The [XR33152](#), [XR33155](#), [XR33156](#) and [XR33158](#) (XR3315x) family of high performance RS-485/RS-422 devices are designed for improved performance in noisy industrial environments and increased tolerance to system faults.

The analog bus pins can withstand direct shorts up to ±60V and are protected against ESD events up to ±15kV HBM. An extended ±25V common mode operating range allows for more reliable operation in noisy environments.

The XR3315x receivers include full fail-safe circuitry, guaranteeing a logic high receiver output when the receiver inputs are open, shorted or undriven. The XR33152/55 receiver input impedance is at least 120kΩ (1/10 unit load), allowing more than 320 devices on the bus. The XR33156/58 receiver input impedance is at least 30kΩ (1/2.5 unit load), allowing more than 80 devices on the bus.

The drivers are protected by short circuit detection as well as thermal shutdown and maintain high impedance in shutdown or when powered off. The XR33152 driver is slew limited for reduced EMI and error-free communication over long or unterminated data cables.

The XR3315x family of high performance RS-485/RS-422 devices are designed for improved performance in noisy industrial environments and increased tolerance to system faults.

The devices with DE and  $\overline{RE}$  pins include hot swap circuitry to prevent false transitions on the bus during power up or live insertion and can enter a 1nA low current shutdown mode for extreme power savings.

### FEATURES

- 3.0V to 5.5V operation
- ±60V fault tolerance on analog bus pins
- Extended ±25V common mode operation
- Robust ESD protection:
  - ±15kV HBM (bus pins)
  - ±4kV HBM (non-bus pins)
- 1.65V to 5.5V logic Interface VL pin (full-duplex package option)
- Invert control to correct for reversed bus pins
- Enhanced receiver fail-safe protection for open, shorted or terminated but idle data lines
- Hot swap glitch protection on DE and  $\overline{RE}$  pins
- Driver short-circuit current limit and thermal shutdown for overload protection
- Reduced unit loads allows up to 320 devices on bus
- Industry standard 8-pin and 14-pin NSOIC packages
- -40°C to 85°C and -40°C to 105°C ambient operating temperature ranges

### APPLICATIONS

- Industrial control networks
- HVAC networks
- Building and process automation
- Remote utility meter reading
- Energy monitoring and control
- Long or unterminated transmission lines

Ordering Information - [Page 20](#)

### Typical Application

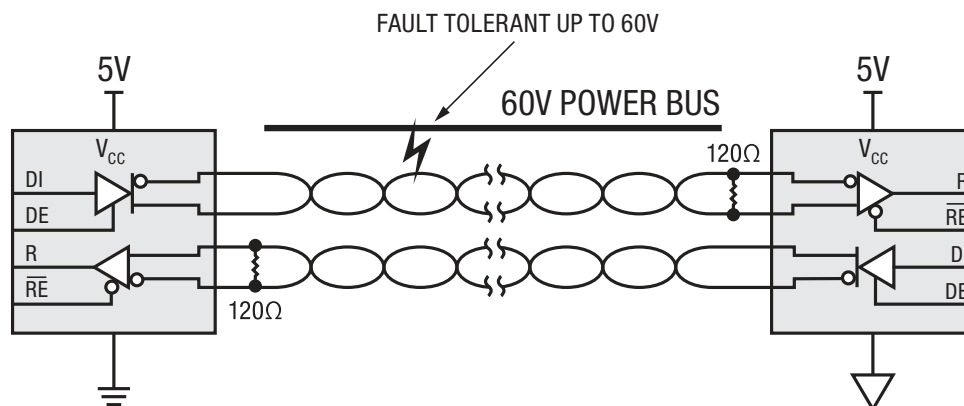

Figure 1. Typical Application

## Absolute Maximum Ratings

Stresses beyond the limits listed below may cause permanent damage to the device. Exposure to any Absolute Maximum Rating condition for extended periods may affect device reliability and lifetime.

$V_{CC}$ .....	-0.3V to 7.0V
$V_L$ .....	$V_L \leq V_{CC}$
Input voltage at control and driver input (DE, DI and INV) XR33152/55/58.....	-0.3V to ( $V_{CC} + 0.3V$ )
Receiver output voltage (RO) XR33152/55/58.....	-0.3V to ( $V_{CC} + 0.3V$ )
Input voltage at control ( $\overline{RE}$ ) XR33156 .....	-0.3V to ( $V_L + 0.3V$ )
Input voltage at control and driver input (DE, DI, $R_{INV}$ , $D_{INV}$ , and INV) XR33156.....	-0.3V to 7.0V
Receiver output voltage (RO) XR33156.....	-0.3V to ( $V_L + 0.3V$ )
Driver output voltage (Y, Z, A/Y and B/Z) .....	$\pm 60V$
Receiver input voltage (A, B, A/Y and B/Z) .....	$\pm 60V$
Transient voltage pulse, through 100 $\Omega$ (Figure 7) .....	$\pm 100V$
Driver output current.....	$\pm 250mA$
Storage temperature range .....	-65°C to 150°C
Lead temperature (soldering 10 seconds).....	300°C
Maximum junction temperature .....	150°C

## ESD Ratings

HBM - Human Body Model (A, B, Y and Z pins) .....	$\pm 15kV$
HBM - Human Body Model (all other pins).....	$\pm 4kV$

## Operating Conditions

Supply voltage range.....	3.0V to 5.5V
Operating temperature range .....	-40°C to 105°C
Package power dissipation, 8-pin NSOIC $\theta_{JA}$ .....	128.4°C/W
Package power dissipation, 14-pin NSOIC $\theta_{JA}$ .....	86°C/W

## Electrical Characteristics

Unless otherwise noted:  $V_{CC} = 3.0V$  to  $5.5V$ ,  $T_A = T_{MIN}$  to  $T_{MAX}$ . Typical values are at  $V_{CC} = 5.0V$ ,  $T_A = 25^\circ C$ .

Symbol	Parameter	Conditions	Min	Typ	Max	Units
<b>Driver DC Characteristics</b>						
$V_{CC}$	Supply voltage range		3.0		5.5	V
$V_L$	I/O logic supply voltage range	$V_L \leq V_{CC}$	1.65		5.5	V
$V_{OD}$	Differential driver output, $4.5V \leq V_{CC} \leq 5.5V$	$R_L = 100\Omega$ (RS-422), Figure 4	2		$V_{CC}$	V
		$R_L = 54\Omega$ (RS-485), Figure 4	1.5		$V_{CC}$	V
		$-25V \leq V_{CM} \leq 25V$ , Figure 5	1.5		$V_{CC}$	V
$V_{OD}$	Differential driver output, $3.0V \leq V_{CC} \leq 4.5V$	$R_L = 100\Omega$ (RS-422), Figure 4	0.85		$V_{CC}$	V
		$R_L = 54\Omega$ (RS-485), Figure 4	0.65		$V_{CC}$	V
$\Delta V_{OD}$	Change in magnitude of differential output voltage, Note 1				$\pm 0.2$	V
$V_{CM}$	Driver common-mode output voltage (steady state)	$R_L = 100\Omega$ (RS-422) or $R_L = 54\Omega$ (RS-485), Figure 4	1		3	V
$\Delta V_{CM}$	Change in magnitude of common-mode output voltage, Note 1				$\pm 0.2$	V
$V_{IH}$	Logic high input thresholds (DI, DE and INV)	$V_{CC} = 3.3V$ , for XR33152/55/58	2.0			V
		$V_{CC} = 5.0V$ , for XR33152/55/58	2.4			V
$V_{IL}$	Logic low input thresholds (DI, DE and INV)	For XR33152/55/58			0.8	V
$V_{IH}$	Logic high input thresholds (DI, DE, RE, $D_{INV}$ and $R_{INV}$ )	$V_L \leq V_{CC}$ , for XR33156	$(2/3)V_L$			V
$V_{IL}$	Logic low input thresholds (DI, DE, RE, $D_{INV}$ and $R_{INV}$ )	$V_L \leq V_{CC}$ , for XR33156			$(1/3)V_L$	V
$V_{HYS}$	Input hysteresis (DI, DE, RE, $D_{INV}$ , $R_{INV}$ and INV)			100		mV
$I_{IN}$	Logic input current (DI, DE and $\overline{RE}$ )	$0V \leq V_{IN} \leq V_{CC}$ , for XR33152/55/58 After first transition, Note 2			$\pm 1$	$\mu A$
	Logic input current (INV)	$V_{IN} = V_{CC} = 5.5V$ , for XR33152/55/58	25	33	55	$\mu A$
	Logic input current (DI, DE and $\overline{RE}$ )	$0V \leq V_{IN} \leq V_L = V_{CC} = 5.5V$ , for XR33156 After first transition, Note 2			$\pm 1$	$\mu A$
	Logic input current ( $D_{INV}$ and $R_{INV}$ )	$V_{IN} = V_L = V_{CC} = 5.5V$ , for XR33156	25	33	55	$\mu A$
$I_{INHS}$	Logic input current hot swap (DE and $\overline{RE}$ )	Until first transition, Note 2		100	$\pm 200$	$\mu A$
$I_{A, B}$	Input current (A and B)	$V_{CC} = 0V$ or $5.5V$ , $V_{OUT} = 12V$ , DE = $0V$ , for XR33152/55			100	$\mu A$
		$V_{CC} = 0V$ or $5.5V$ , $V_{OUT} = -7V$ , DE = $0V$ , for XR33152/55	-80			$\mu A$
		$V_{OUT} = 12V$ , DE = $0V$ , $V_{CC} = 0V$ or $5.5V$ , for XR33156/58			400	$\mu A$
		$V_{OUT} = -7V$ , DE = $0V$ , $V_{CC} = 0V$ or $5.5V$ , for XR33156/58	-320			$\mu A$

**NOTES:**

- Change in magnitude of differential output voltage and change in magnitude of common mode output voltage are the changes in output voltage when DI input changes state.
- The hot swap feature disables the DE and  $\overline{RE}$  inputs for the first 10 $\mu s$  after power is applied. Following this time period, these inputs are weakly pulled to their disabled state (low for DE, high for RE) until the first transition, after which they become high impedance inputs.

**Electrical Characteristics (Continued)**

Unless otherwise noted:  $V_{CC} = 3.0V$  to  $5.5V$ ,  $T_A = T_{MIN}$  to  $T_{MAX}$ . Typical values are at  $V_{CC} = 5.0V$ ,  $T_A = 25^\circ C$ .

Symbol	Parameter	Conditions	Min	Typ	Max	Units
$I_{OL}$	Output leakage (Y and Z) Full-duplex	$V_{OUT} = 12V$ , $DE = 0V$ , $V_{CC} = 0V$ or $5.5V$			100	$\mu A$
		$V_{OUT} = -7V$ , $DE = 0V$ , $V_{CC} = 0V$ or $5.5V$	-80			$\mu A$
$I_{OSD}$	Driver short-circuit output current	$-60V \leq V_{OUT} \leq 60V$ , Figure 6			$\pm 250$	mA
<b>Driver Thermal Characteristics</b>						
$T_{TS}$	Thermal shutdown temperature	Junction temperature, Note 1		175		$^\circ C$
$T_{TSH}$	Thermal shutdown hysteresis	Note 1		15		$^\circ C$
<b>Receiver DC Characteristics</b>						
$V_{STH}$	Receiver differential input signal threshold voltage ( $V_A - V_B$ )	$-25V \leq V_{OUT} \leq 25V$		$\pm 85$	$\pm 200$	mV
$\Delta V_{STH}$	Receiver differential input signal hysteresis			170		mV
$V_{FSTH-}$	Negative going receiver differential input failsafe threshold voltage ( $V_A - V_B$ )	$-25V \leq V_{OUT} \leq 25V$	-200	-125	-40	mV
$V_{FSTH+}$	Positive going receiver differential input failsafe threshold voltage ( $V_A - V_B$ )	$-25V \leq V_{OUT} \leq 25V$		-100	-10	mV
$\Delta V_{FSTH}$	Receiver differential input failsafe hysteresis			25		mV
$V_{OH}$	Receiver output high voltage (RO)	$I_{OUT} = -4mA$ , for XR33152/55/58	$V_{CC} - 0.6$			V
$V_{OL}$	Receiver output low voltage (RO)	$I_{OUT} = 4mA$ , for XR33152/55/58			0.4	V
$V_{OH}$	Receiver output high voltage (RO)	$3.0V \leq V_L \leq 5.5V$ , $I_{OUT} = -4mA$ , $1.6V \leq V_L \leq 3.0V$ , $I_{OUT} = -1mA$ , for XR33156	$V_L - 0.6$			V
$V_{OL}$	Receiver output low voltage (RO)	$3.0V \leq V_L \leq 5.5V$ , $I_{OUT} = 4mA$ , $1.6V \leq V_L \leq 3.0V$ , $I_{OUT} = 1mA$ , for XR33156			0.4	V
$I_{OZR}$	High-Z receiver output current	$0V \leq V_{OUT} \leq V_{CC}$ , for XR33152/55/58 $0V \leq V_{OUT} \leq V_L$ , for XR33156			$\pm 1$	$\mu A$
$R_{IN}$	RX input resistance	$-25V \leq V_{CM} \leq 25V$ , for XR33152/55	120			k $\Omega$
		$-25V \leq V_{CM} \leq 25V$ , for XR33156/58	30			k $\Omega$
$I_{OSC}$	RX output short-circuit current	$0V \leq V_{RO} \leq V_{CC}$ , for XR33152/55/58			110	mA
	RX output short-circuit current	$0V \leq V_{RO} \leq V_L$ , for XR33156			110	mA
<b>Supply Current</b>						
$I_{CC}$	Supply current	No load, $\overline{RE} = 0V$ or $V_{CC}$ , $DE = V_{CC}$ , $DI = 0V$ or $V_{CC}$			4	mA
$I_{SHDN}$	Supply current in shutdown mode	$\overline{RE} = V_{CC}$ , $DE = 0V$		0.001	1	$\mu A$

**NOTES:**

1. This spec is guaranteed by design and bench characterization.

## Electrical Characteristics (Continued)

### Driver AC Characteristics - XR33152 (250kbps)

Unless otherwise noted:  $V_{CC} = 3.0V$  to  $5.5V$ ,  $T_A = T_{MIN}$  to  $T_{MAX}$ . Typical values are at  $V_{CC} = 5.0V$ ,  $T_A = 25^\circ C$ .

Symbol	Parameter	Conditions	Min	Typ	Max	Units
$t_{DPLH}$	Driver propagation delay (low to high)	$C_L = 50pF$ , $R_L = 54\Omega$ , Figure 7	350		1500	ns
$t_{DPHL}$	Driver propagation delay (high to low)		350		1600	ns
$ t_{DPLH} - t_{DPHL} $	Differential driver output skew			20	200	ns
$t_{DR}$ , $t_{DF}$	Driver differential output rise or fall time			400		1500
	Maximum data rate	$1/t_{UI}$ , duty cycle 40% to 60%	250			kbps
$t_{DZH}$	Driver enable to output high	$C_L = 50pF$ , $R_L = 500\Omega$ , Figure 8		200	2500	ns
$t_{DZL}$	Driver enable to output low			200	2500	ns
$t_{DZH}$	Driver disable from output high				250	ns
$t_{DLZ}$	Driver disable from output low				250	ns
$t_{RZH}(SHDN)$	Driver enable from shutdown to output high	$C_L = 50pF$ , $R_L = 500\Omega$ , Figure 8			5500	ns
$t_{RZL}(SHDN)$	Driver enable from shutdown to output low				5500	ns
$t_{SHDN}$	Time to shutdown	Notes 1 and 2	50	200	600	ns

### Receiver AC Characteristics -XR33152 (250kbps)

Unless otherwise noted:  $V_{CC} = 3.0V$  to  $5.5V$ ,  $T_A = T_{MIN}$  to  $T_{MAX}$ . Typical values are at  $V_{CC} = 5.0V$ ,  $T_A = 25^\circ C$ .

Symbol	Parameter	Conditions	Min	Typ	Max	Units
$t_{RPLH}$	Receiver propagation delay (low to high)	$C_L = 15pF$ , $V_{ID} = \pm 2V$ , $V_{ID}$ rise and fall times $< 15ns$ , Figure 9			200	ns
$t_{RPHL}$	Receiver propagation delay (high to low)				200	ns
$ t_{RPLH} - t_{RPHL} $	Receiver propagation delay skew				30	ns
	Maximum data rate	$1/t_{UI}$ , duty cycle 40% to 60%	250			kbps
$t_{RZH}$	Receiver enable to output high	$C_L = 15pF$ , $R_L = 1k\Omega$ , Figure 10			50	ns
$t_{RZL}$	Receiver enable to output low				50	ns
$t_{RHZ}$	Receiver disable from output high				50	ns
$t_{RLZ}$	Receiver disable from output low				50	ns
$t_{RZH}(SHDN)$	Receiver enable from shutdown to output high	$C_L = 15pF$ , $R_L = 1k\Omega$ , Figure 10			3500	ns
$t_{RZL}(SHDN)$	Receiver enable from shutdown to output low				3500	ns
$t_{SHDN}$	Time to shutdown	Notes 1 and 2	50	200	600	ns

#### NOTES:

1. The transceivers are put into shutdown by bringing  $\overline{RE}$  high and DE low simultaneously for at least 600ns. If the control inputs are in this state for less than 50ns, the device is guaranteed to not enter shutdown. If the enable inputs are held in this state for at least 600ns, the device is ensured to be in shutdown. Note that the receiver and driver enable times increase significantly when coming out of shutdown.
2. This spec is guaranteed by design and bench characterization.

**Electrical Characteristics (Continued)**

**Driver AC Characteristics - XR33155 (1Mbps)**

Unless otherwise noted:  $V_{CC} = 3.0V$  to  $5.5V$ ,  $T_A = T_{MIN}$  to  $T_{MAX}$ . Typical values are at  $V_{CC} = 5.0V$ ,  $T_A = 25^{\circ}C$ .

Symbol	Parameter	Conditions	Min	Typ	Max	Units	
$t_{DPLH}$	Driver propagation delay (low to high)	$C_L = 50pF$ , $R_L = 54\Omega$ , Figure 7		150	500	ns	
$t_{DPHL}$	Driver propagation delay (high to low)			150	500	ns	
$ t_{DPLH}-t_{DPHL} $	Differential driver output skew				5	50	ns
$t_{DR}$ , $t_{DF}$	Driver differential output rise or fall time			100	200	300	ns
	Maximum data rate	$1/t_{UI}$ , duty cycle 40% to 60%	1			Mbps	
$t_{DZH}$	Driver enable to output high	$C_L = 50pF$ , $R_L = 500\Omega$ , Figure 8		1000	2500	ns	
$t_{DZL}$	Driver enable to output low			1000	2500	ns	
$t_{DZH}$	Driver disable from output high				250	ns	
$t_{DLZ}$	Driver disable from output low				250	ns	
$t_{DZH}(SHDN)$	Driver enable from shutdown to output high	$C_L = 50pF$ , $R_L = 500\Omega$ , Figure 8		2500	4500	ns	
$t_{DZL}(SHDN)$	Driver enable from shutdown to output low			2500	4500	ns	
$t_{SHDN}$	Time to shutdown	Notes 1 and 2	50	200	600	ns	

**Receiver AC Characteristics - XR33155 (1Mbps)**

Unless otherwise noted:  $V_{CC} = 3.0V$  to  $5.5V$ ,  $T_A = T_{MIN}$  to  $T_{MAX}$ . Typical values are at  $V_{CC} = 5.0V$ ,  $T_A = 25^{\circ}C$ .

Symbol	Parameter	Conditions	Min	Typ	Max	Units
$t_{RPLH}$	Receiver propagation delay (low to high)	$C_L = 15pF$ , $V_{ID} = \pm 2V$ , $V_{ID}$ rise and fall times < 15ns, Figure 9			200	ns
$t_{RPHL}$	Receiver propagation delay (high to low)				200	ns
$ t_{RPLH}-t_{RPHL} $	Receiver propagation delay skew				30	ns
	Maximum data rate	$1/t_{UI}$ , duty cycle 40% to 60%	1			Mbps
$t_{RZH}$	Receiver enable to output high	$C_L = 15pF$ , $R_L = 1k\Omega$ , Figure 10			50	ns
$t_{RZL}$	Receiver enable to output low				50	ns
$t_{RHZ}$	Receiver disable from output high				50	ns
$t_{RLZ}$	Receiver disable from output low				50	ns
$t_{RZH}(SHDN)$	Receiver enable from shutdown to output high	$C_L = 15pF$ , $R_L = 1k\Omega$ , Figure 10			3500	ns
$t_{RZL}(SHDN)$	Receiver enable from shutdown to output low				3500	ns
$t_{SHDN}$	Time to shutdown	Notes 1 and 2	50	200	600	ns

**NOTES:**

1. The transceivers are put into shutdown by bringing  $\overline{RE}$  high and DE low simultaneously for at least 600ns. If the control inputs are in this state for less than 50ns, the device is guaranteed to not enter shutdown. If the enable inputs are held in this state for at least 600ns, the device is ensured to be in shutdown. Note that the receiver and driver enable times increase significantly when coming out of shutdown.
2. This spec is guaranteed by design and bench characterization.

## Electrical Characteristics (Continued)

## Driver AC Characteristics - XR33156 and XR33158 (20Mbps)

Unless otherwise noted:  $V_{CC} = 3.0V$  to  $5.5V$ ,  $T_A = T_{MIN}$  to  $T_{MAX}$ . Typical values are at  $V_{CC} = 5.0V$ ,  $T_A = 25^\circ C$ .

Symbol	Parameter	Conditions	Min	Typ	Max	Units
$t_{DPLH}$	Driver prop. delay (low to high)	$C_L = 50pF$ , $R_L = 54\Omega$ , Figure 7			25	ns
$t_{DPHL}$	Driver prop. delay (high to low)				25	ns
$ t_{DPLH} - t_{DPHL} $	Differential driver output skew				5	ns
$t_{DR}$ , $t_{DF}$	Driver differential output rise or fall time				15	ns
	Maximum data rate	$1/t_{UI}$ , duty cycle 40% to 60%	20			Mbps
$t_{DZH}$	Driver enable to output high	$C_L = 50pF$ , $R_L = 500\Omega$ , Figure 8			60	ns
$t_{DZL}$	Driver enable to output low				60	ns
$t_{DZH}$	Driver disable from output high				250	ns
$t_{DLZ}$	Driver disable from output low				250	ns
$t_{DZH(SHDN)}$	Driver enable from shutdown to output high	$C_L = 50pF$ , $R_L = 500\Omega$ , Figure 8			2200	ns
$t_{DZL(SHDN)}$	Driver enable from shutdown to output low				2200	ns
$t_{SHDN}$	Time to shutdown	Notes 1 and 2	50	200	600	ns

## Receiver AC Characteristics - XR33156 and XR33158 (20Mbps)

Unless otherwise noted:  $V_{CC} = 3.0V$  to  $5.5V$ ,  $T_A = T_{MIN}$  to  $T_{MAX}$ . Typical values are at  $V_{CC} = 5.0V$ ,  $T_A = 25^\circ C$ .

Symbol	Parameter	Conditions	Min	Typ	Max	Units
$t_{RPLH}$	Receiver prop. delay (low to high)	$C_L = 15pF$ , $V_{ID} = \pm 2V$ , $V_{ID}$ rise and fall times < 15ns, Figure 9			60	ns
$t_{RPHL}$	Receiver prop. delay (high to low)				60	ns
$ t_{RPLH} - t_{RPHL} $	Receiver propagation delay skew				5	ns
	Maximum data rate	$1/t_{UI}$ , duty cycle 40% to 60%	20			Mbps
$t_{RZH}$	Receiver enable to output high	$C_L = 15pF$ , $R_L = 1k\Omega$ , Figure 10, for XR33156			50	ns
$t_{RZL}$	Receiver enable to output low				50	ns
$t_{RZH}$	Receiver disable from output high				50	ns
$t_{RLZ}$	Receiver disable from output low				50	ns
$t_{RZH(SHDN)}$	Receiver enable from shutdown to output high	$C_L = 15pF$ , $R_L = 1k\Omega$ , Figure 10, for XR33156			2200	ns
$t_{RZL(SHDN)}$	Receiver enable from shutdown to output low				2200	ns
$t_{SHDN}$	Time to shutdown	Notes 1 and 2, for XR33156	50	200	600	ns

## NOTES:

- The transceivers are put into shutdown by bringing  $\overline{RE}$  high and DE low simultaneously for at least 600ns. If the control inputs are in this state for less than 50ns, the device is guaranteed to not enter shutdown. If the enable inputs are held in this state for at least 600ns, the device is ensured to be in shutdown. Note that the receiver and driver enable times increase significantly when coming out of shutdown.
- This spec is guaranteed by design and bench characterization.

Pin Configurations

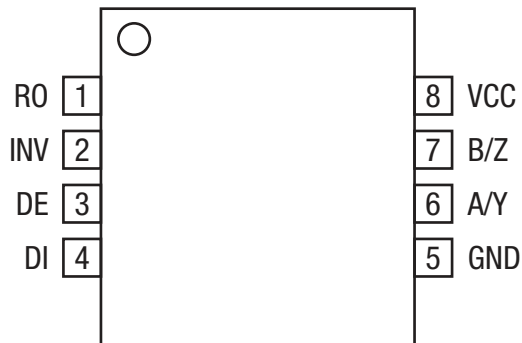

XR33152, XR33155 and XR33158 Half-duplex

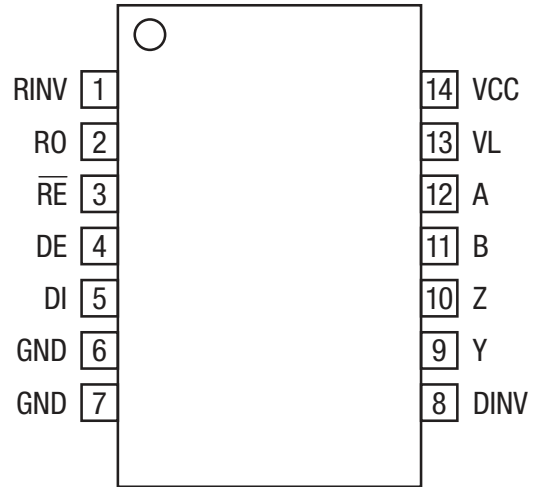

XR33156 Full-duplex

Pin Functions

Pin Number		Pin Name	Type	Description
Half-duplex XR33152 XR33155 XR33158	Full-duplex XR33156			
-	1	RINV	I	Receiver invert control (active high). When enabled, the polarity of the receiver bus pins (A & B) is reversed: A = inverting and B = non-inverting. When disabled, the receiver bus pins (A & B) operate normally: A = non-inverting and B = inverting. The R <sub>INV</sub> pin has a 150kΩ pull-down resistor.
1	2	RO	O	Receiver output, when $\overline{RE}$ is low and if (A-B) ≥ 200mV, RO is high. If (A-B) ≤ -200mV, RO is low. If inputs are left floating, shorted together or terminated and undriven for more than 2μs the output is high.
2	-	INV	I	Driver and receiver invert control (active high). When enabled, the polarity of the driver input and receiver input bus pins is inverted. When disabled, the driver input and receiver inputs operate normally: A = non-inverting and B = inverting. The INV pin has a 150kΩ pull-down resistor.
-	3	$\overline{RE}$	I	Receiver output enable (hot swap). When $\overline{RE}$ is low, RO is enabled. When $\overline{RE}$ is high, RO is high impedance. $\overline{RE}$ should be high and DE should be low to enter shutdown mode.
3	4	DE	I	Driver output enable (hot swap). When DE is high, outputs are enabled. When DE is low, outputs are high impedance. DE should be low and $\overline{RE}$ should be high to enter shutdown mode.
4	5	DI	I	Driver input. With DE high, a low level on DI forces non-inverting output low and inverting output high. Similarly, a high level on DI forces non-inverting output high and inverting output low.
5	6, 7	GND	PWR	Ground.
6	-	A/Y	I/O	Non-inverting receiver input and non-Inverting driver output.
7	-	B/Z	I/O	Inverting receiver input and Inverting driver output.

**NOTE:**  
Type: I = Input, O = Output, I/O = Input/Output, PWR = Power.



## Pin Functions (Continued)

Pin Number		Pin Name	Type	Description
Half-duplex XR33152 XR33155 XR33158	Full-duplex XR33156			
8	14	VCC	PWR	3.0V to 5.5V power supply input bypass to ground with 0.1 $\mu$ F capacitor.
-	12	A	I	Non inverting receiver input.
-	11	B	I	Inverting receiver input.
-	9	Y	O	Non-inverting driver output.
-	10	Z	O	Inverting driver output.
-	8	DINV	I	Driver invert control (active high). When enabled, the polarity of the driver input pin is inverted causing the driver output (Y & Z) polarities to be inverted. When disabled, the driver bus pins (Y & Z) operate normally: Y = non-inverting and Z = inverting. The D <sub>INV</sub> pin has a 150k $\Omega$ pull-down resistor.
-	13	VL	PWR	Logic interface power supply.

**NOTE:**

Type: I = Input, O = Output, I/O = Input/Output, PWR = Power.

**Pin Functions (Continued)**

XR33156 (Full-duplex - 14 Pins)

Transmitting					
Inputs				Outputs	
D <sub>INV</sub>	$\overline{RE}$	DE	DI	Y	Z
0	X	1	1	1	0
0	X	1	0	0	1
1	X	1	1	0	1
1	X	1	0	1	0
X	0	0	X	High-Z	
X	1	0	X	High-Z (shutdown)	

XR33156 (Full-duplex - 14 Pins)

Receiving				
Inputs				Output
R <sub>INV</sub>	$\overline{RE}$	DE	V <sub>A</sub> - V <sub>B</sub>	RO
0	0	X	$\geq 200mV$	1
0	0	X	$\leq -200mV$	0
0	0	X	Open/shorted	1
1	0	X	$\geq 200mV$	0
1	0	X	$\leq -200mV$	1
1	0	X	Open/shorted	1
X	1	1	X	High-Z
X	1	0	X	High-Z (shutdown)

XR33152, XR33155 and XR33158 (Half-duplex - 8 Pins)

Transmitting				
Inputs			Outputs	
INV	DE	DI	A/Y	B/Z
0	1	1	1	0
0	1	0	0	1
1	1	1	0	1
1	1	0	1	0
X	0	X	High-Z	

XR33152, XR33155 and XR33158 (Half-duplex - 8 Pins)

Receiving			
Inputs			Output
INV	DE	V <sub>A</sub> - V <sub>B</sub>	RO
0	0	$\geq 200mV$	1
0	0	$\leq -200mV$	0
1	0	Open/shorted	1
1	0	$\geq +200mV$	0
1	0	$\leq -200mV$	1
1	0	Open/shorted	1

**Applications Information**

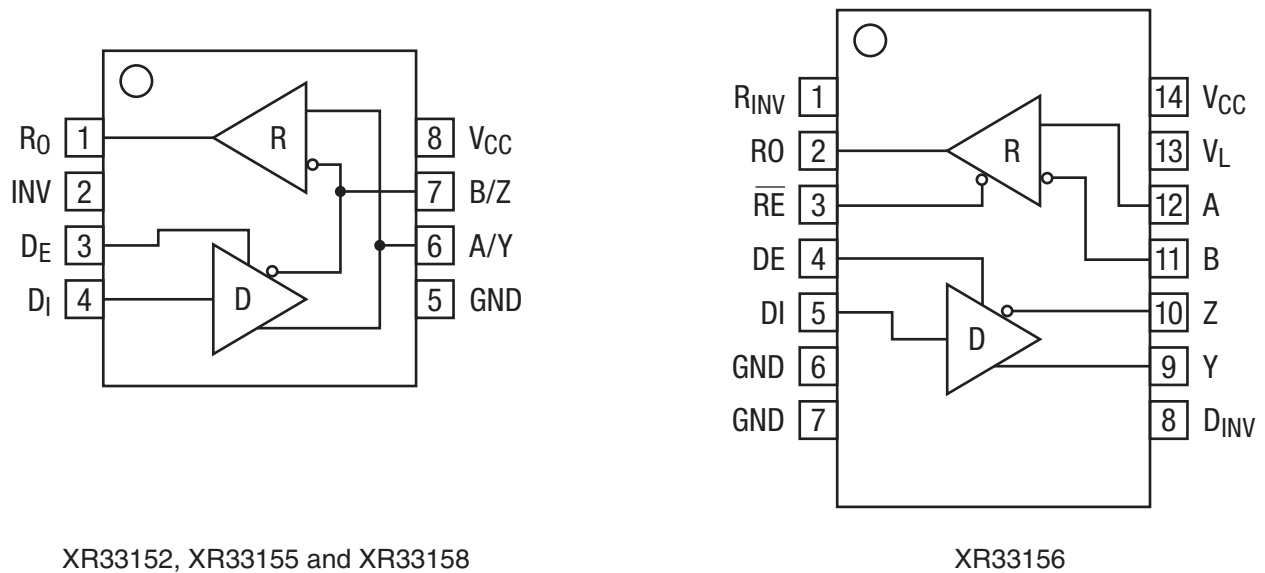

XR33152, XR33155 and XR33158

XR33156

Figure 2. XR33152, XR33155 and XR33158 Half-duplex and XR33156 Full-duplex

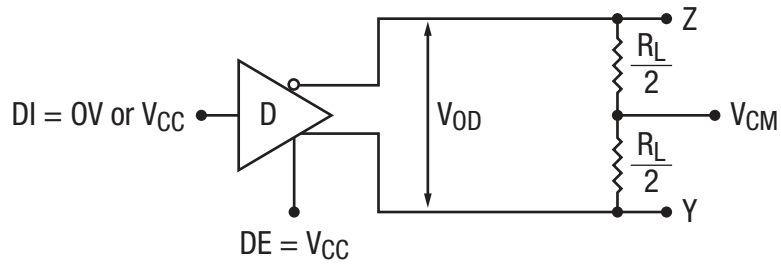

Figure 3. Differential Driver Output Voltage

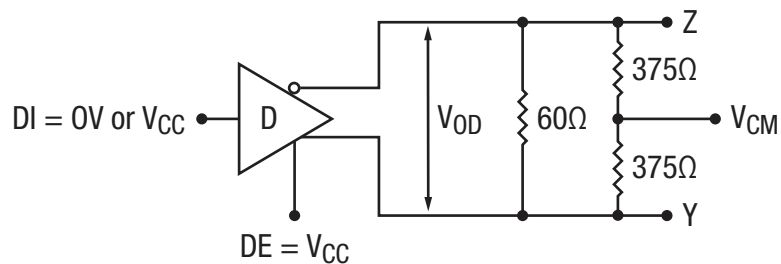

Figure 4. Differential Driver Output Voltage Over Common Mode

Applications Information (Continued)

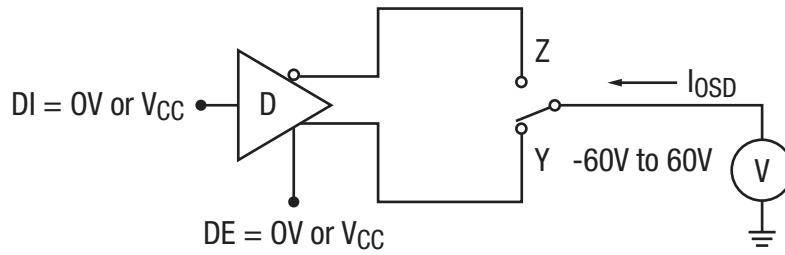

Figure 5. Driver Output Short Circuit Current

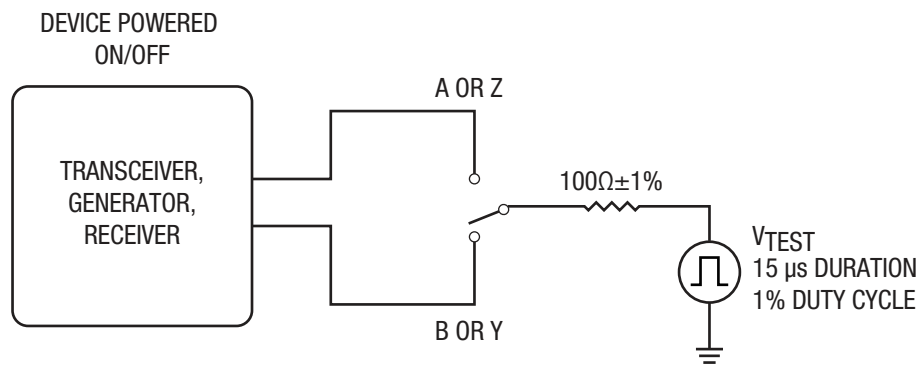

Figure 6. Transient Overvoltage Test Circuit

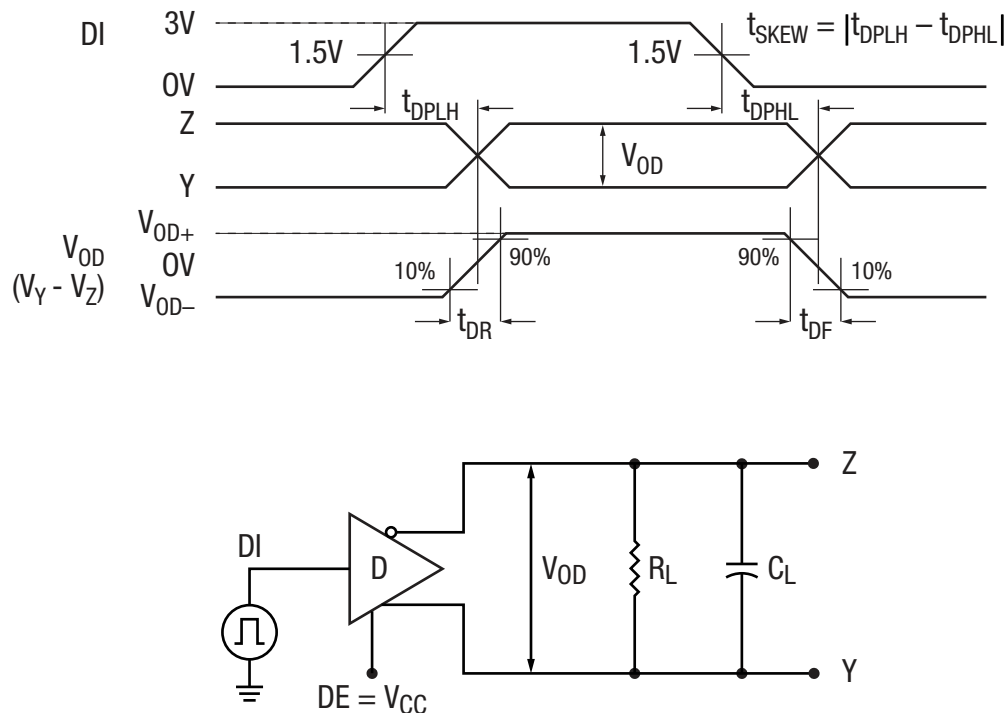

Figure 7. Driver Propagation Delay Test Circuit and Timing Diagram

Applications Information (Continued)

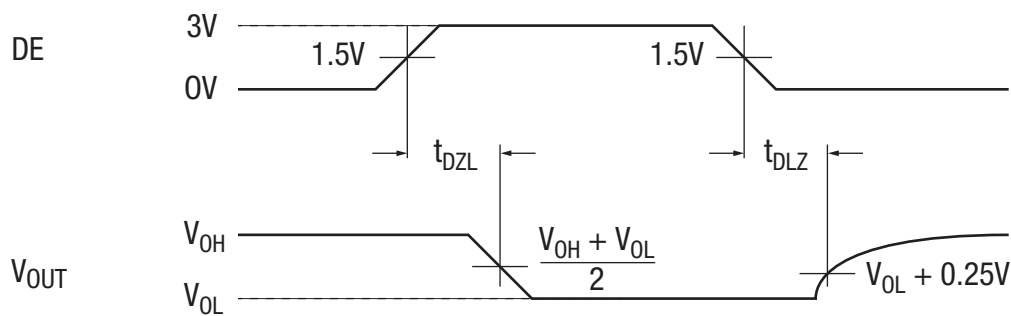
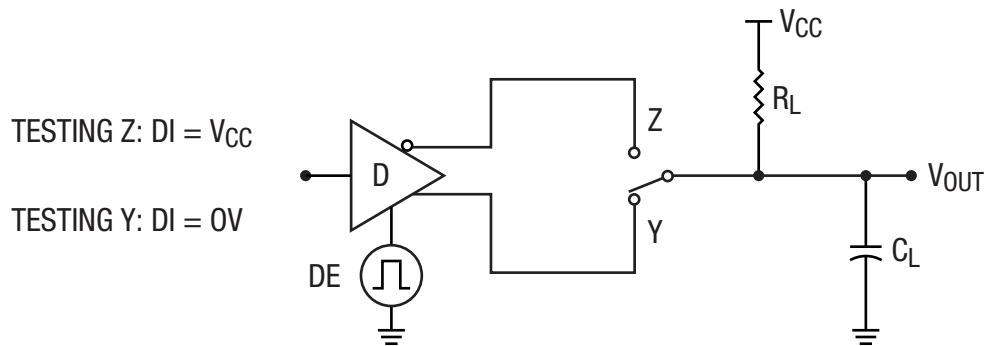
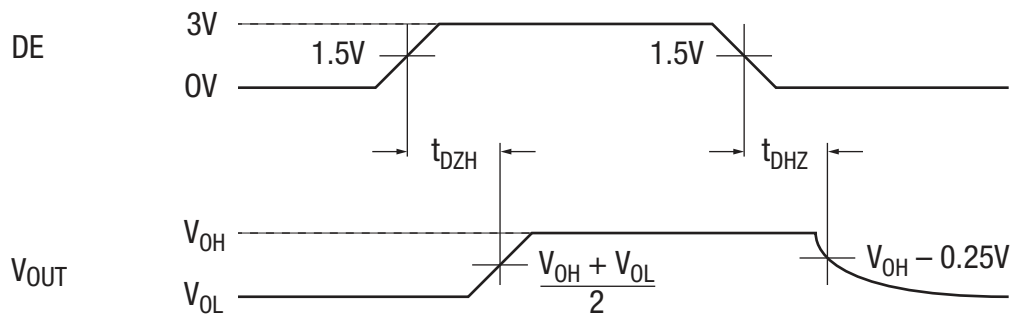
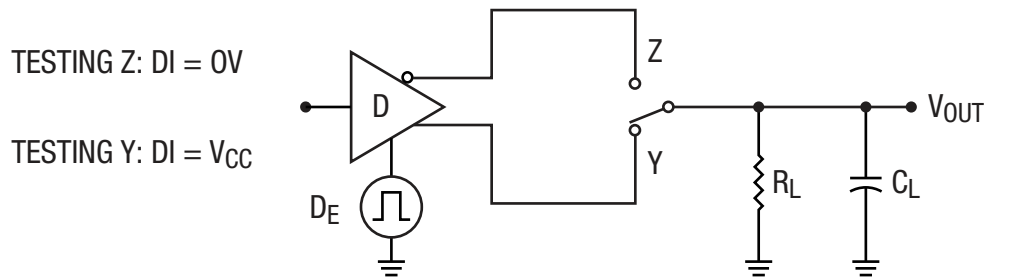

Figure 8. Driver Enable and Disable Timing Test Circuits and Timing Diagrams

Applications Information (Continued)

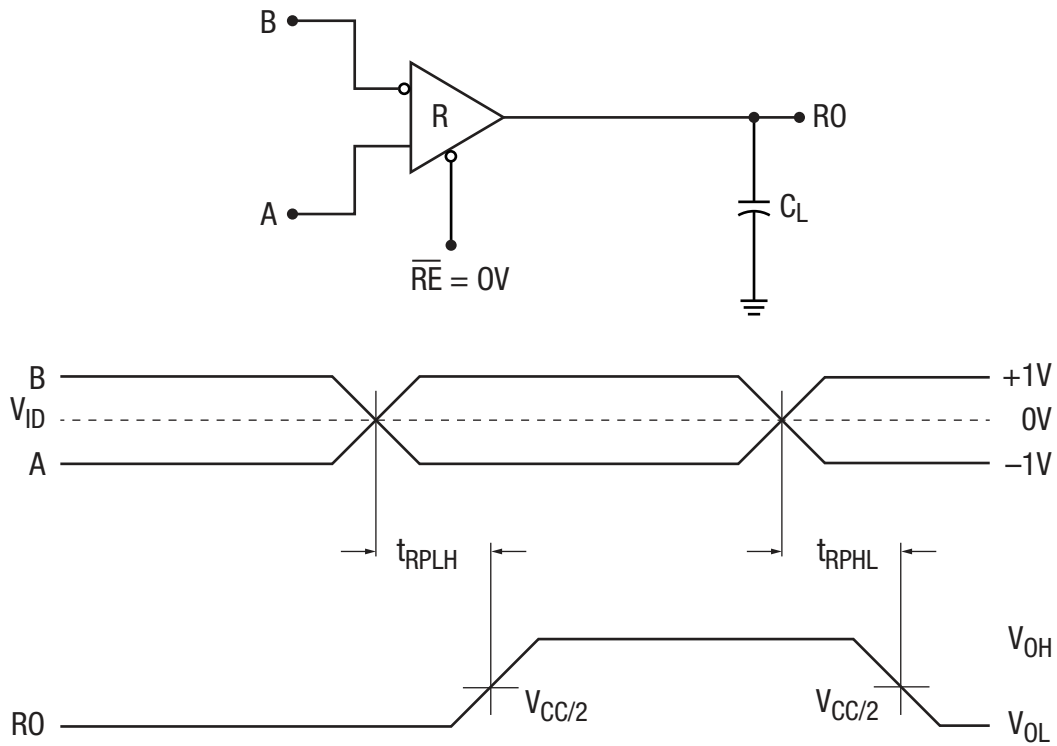

Figure 9. Receiver Propagation Delay Test Circuit and Timing Diagram

Applications Information (Continued)

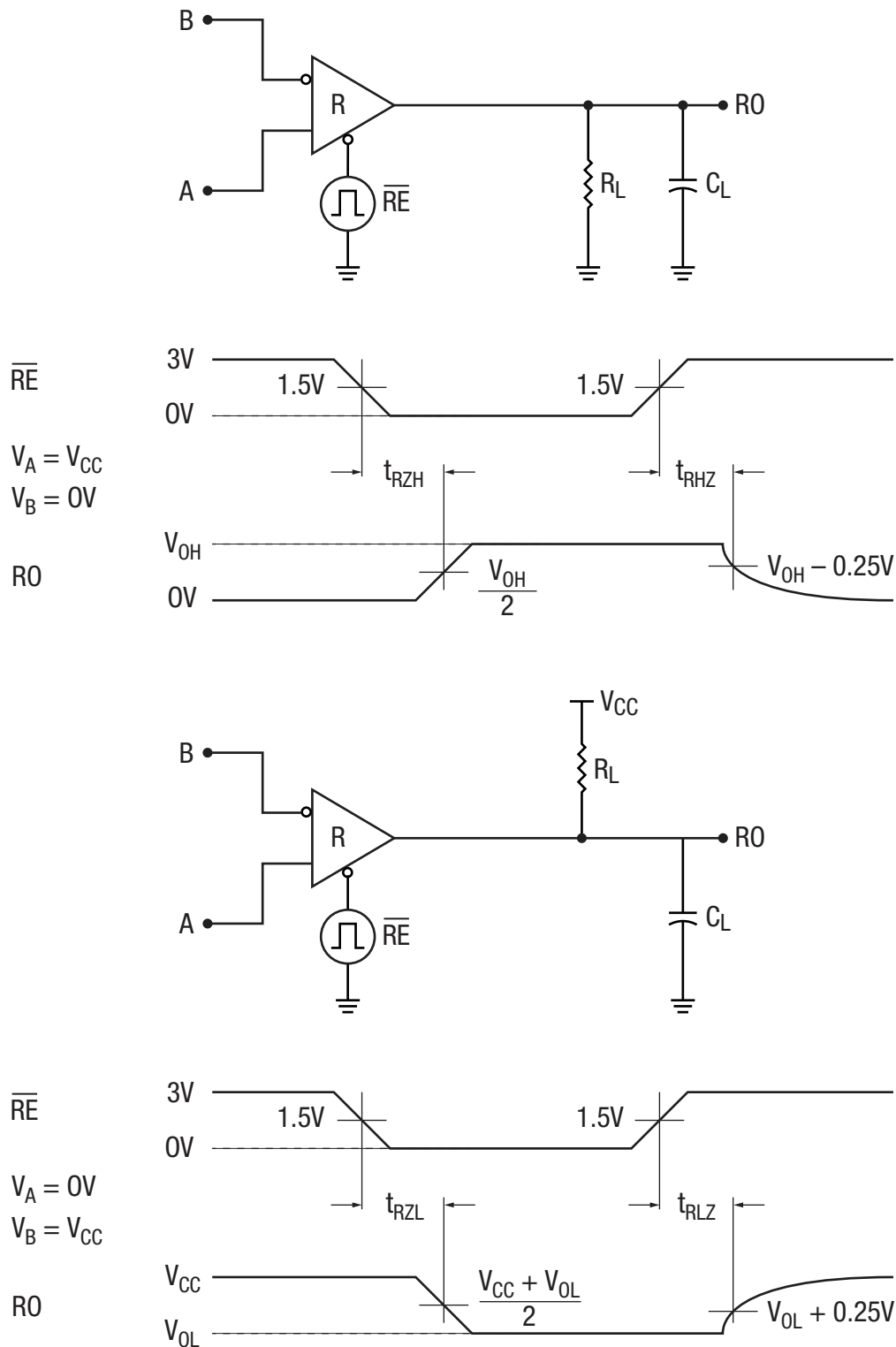

Figure 10. Receiver Enable and Disable Test Circuits and Timing Diagrams

## Applications Information (Continued)

The XR3315x RS-485/RS-422 devices are part of MaxLinear's high performance serial interface product line. The analog bus pins can survive direct shorts up to  $\pm 60\text{V}$  and are protected against ESD events up to  $\pm 15\text{kV}$ .

### Enhanced Failsafe

Ordinary RS-485 differential receivers will be in an indeterminate state whenever the data bus is not being actively driven. The enhanced failsafe feature of the XR3315x family guarantees a logic-high receiver output when the receiver inputs are open, shorted or when they are connected to a terminated transmission line with all drivers disabled. In a terminated bus with all transmitters disabled, the receivers' differential input voltage is pulled to 0V by the termination. The XR3315x family interprets 0V differential as a logic high with a minimum 50mV noise margin while maintaining compliance with the RS-485 standard of  $\pm 200\text{mV}$ . Although the XR3315x family does not need failsafe biasing resistors, it can operate without issue if biasing is used.

### Hot Swap Capability

When  $V_{CC}$  is first applied the XR3315x family holds the driver enable and receiver enable inactive for approximately 10 $\mu\text{s}$ . During power ramp-up, other system ICs may drive unpredictable values or tristated lines may be influenced by stray capacitance. The hot swap feature prevents the XR3315x family from driving any output signal until power has stabilized. After the initial 10 $\mu\text{s}$ , the driver and receiver enable pins are weakly pulled to their disabled states (low for DE and high for  $\overline{\text{RE}}$ ) until the first transition. After the first transition, the DE and  $\overline{\text{RE}}$  pins operate as high impedance inputs.

If circuit boards are inserted into an energized backplane (commonly called "live insertion" or "hot swap") power may suddenly be applied to all circuits. Without the hot swap capability, this situation could improperly enable the transceiver's driver or receiver, driving invalid data onto shared buses and possibly causing driver contention or device damage.

### Driver Output Protection

Two mechanisms prevent excessive output current and power dissipation caused by faults or by bus contention. First, a driver current limit on the output stage provides immediate protection against short circuits over the whole common-mode voltage range. Second, a thermal shutdown circuit forces the driver outputs into a high impedance state if junction temperature becomes excessive.

### Line Length

The RS-485/RS-422 standard covers line lengths up to 4000ft. Maximum achievable line length is a function of signal attenuation and noise. Termination prevents signal reflections by eliminating the impedance mismatches on a transmission line. Line termination is generally used if rise and fall times are shorter than the round trip signal propagation time. Higher output drivers may allow longer cables to be used.

### $\pm 15\text{kV}$ HBM ESD Protection (Unpowered Part)

ESD protection structures are incorporated on all pins to protect against electrostatic discharges encountered during handling and assembly. The driver outputs and receiver inputs of the XR3315x family have extra protection against static electricity. MaxLinear uses state-of-the-art structures to protect these pins against ESD damage:

- $\pm 15\text{kV}$  HBM for bus pins to GND
- $\pm 4\text{kV}$  HBM for all other pins

### ESD Test Conditions

ESD performance depends on a variety of conditions. Contact MaxLinear for a reliability report that documents test setup, methodology and results.

### Maximum Number of Transceivers on the Bus

The standard RS-485 receiver input impedance is 12k $\Omega$  (1 unit load). A standard driver can drive up to 32 unit loads. The XR33152 transceiver has a 1/10th unit load receiver input impedance of 120k $\Omega$ , allowing up to 320 transceivers to be connected in parallel on a communication line. The XR33156/58 transceivers have a 1/2.5 unit load receiver input impedance of 30k $\Omega$ , allowing up to 80 transceivers to be connected in parallel on a communication line. Any combination of these devices and other RS-485 transceivers up to a total of 32 unit loads may be connected to the line.

### Low Power Shutdown Mode

The XR33156 has a low-power shutdown mode that is initiated by bringing both  $\overline{\text{RE}}$  high and DE low simultaneously. While in shutdown the XR33156 draws less than 1 $\mu\text{A}$  of supply current. DE and  $\overline{\text{RE}}$  may be tied together and driven by a single control signal. Devices are guaranteed not to enter shutdown if  $\overline{\text{RE}}$  is high and DE is low for less than 50ns. If the inputs are in this state for at least 600ns, the parts will enter shutdown.

XR33156 enable times,  $t_{ZH}$  and  $t_{ZL}$ , apply when the part is not in low power shutdown state. Enable times,  $t_{ZH(SHDN)}$  and  $t_{ZL(SHDN)}$  apply when the part is shutdown. The driver and receiver take longer to become enabled from low power shutdown  $t_{ZH(SHDN)}$  and  $t_{ZL(SHDN)}$  than from driver or receiver disable mode ( $t_{ZH}$  and  $t_{ZL}$ ).



**Applications Information (Continued)****Product Selector Guide**

Part Number	Operation	Data Rate	Shutdown	Receiver/Driver Enable	Nodes On Bus	Footprint
XR33152	Half-duplex	250kbps	No	No/Yes	320	8-NSOIC
XR33155	Half-duplex	1Mbps				
XR33156	Full-duplex	20Mbps	Yes	Yes/Yes	80	14-NSOIC
XR33158	Half-duplex		No	No/Yes	80	8-NSOIC

Mechanical Dimensions

NSOIC-8

Top View

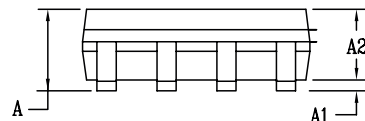
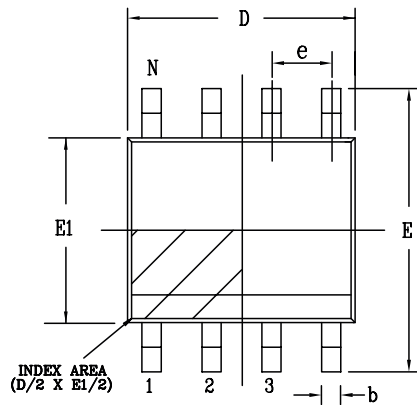

Side View

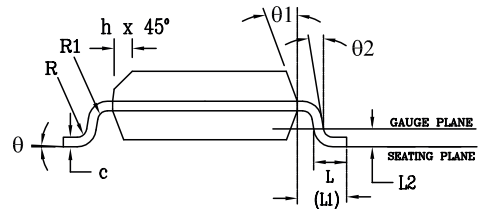

Front View

PACKAGE OUTLINE NSOIC .150" BODY JEDEC MS-012 VARIATIONAA						
SYMBOLS	COMMON DIMENSIONS IN MM (Control Unit)			COMMON DIMENSIONS IN INCH (Reference Unit)		
	MIN	NOM	MAX	MIN	NOM	MAX
A	1.35	—	1.75	0.053	—	0.069
A1	0.10	—	0.25	0.004	—	0.010
A2	1.25	—	1.65	0.049	—	0.065
b	0.31	—	0.51	0.012	—	0.020
c	0.17	—	0.25	0.007	—	0.010
E	6.00 BSC			0.236 BSC		
E1	3.90 BSC			0.154 BSC		
e	1.27 BSC			0.050 BSC		
h	0.25	—	0.50	0.010	—	0.020
L	0.40	—	1.27	0.016	—	0.050
L1	1.04 REF			0.041 REF		
L2	0.25 BSC			0.010 BSC		
R	0.07	—	—	0.003	—	—
R1	0.07	—	—	0.003	—	—
q	0°	—	8°	0°	—	8°
q1	5°	—	15°	5°	—	15°
q2	0°	—	—	0°	—	—
D	4.90 BSC			0.193 BSC		
N	8					

Drawing No: POD-00000108

Revision: A

Mechanical Dimensions

NSOIC-14

Top View

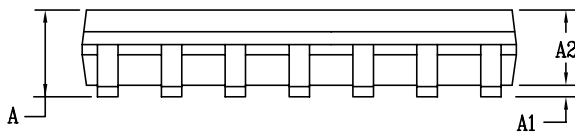
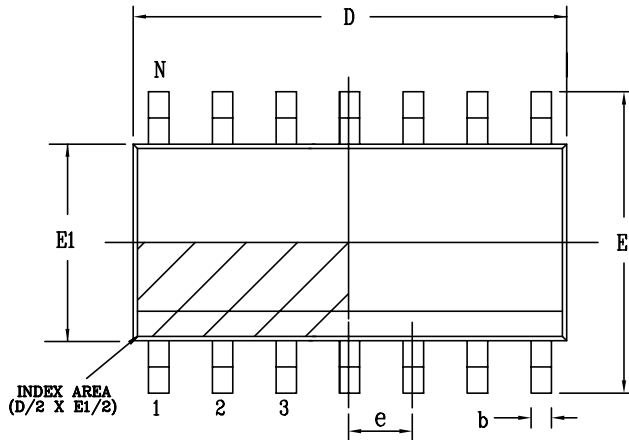

Side View

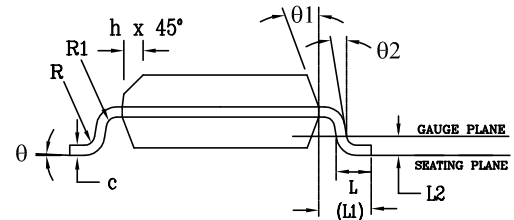

Front View

PACKAGE OUTLINE NSOIC .150" BODY JEDEC MS-012 VARIATION AB						
SYMBOLS	COMMON DIMENSIONS IN MM (Control Unit)			COMMON DIMENSIONS IN INCH (Reference Unit)		
	MIN	NOM	MAX	MIN	NOM	MAX
A	1.35	—	1.75	0.053	—	0.069
A1	0.10	—	0.25	0.004	—	0.010
A2	1.25	—	1.65	0.049	—	0.065
b	0.31	—	0.51	0.012	—	0.020
c	0.17	—	0.25	0.007	—	0.010
E	6.00 BSC			0.236 BSC		
E1	3.90 BSC			0.154 BSC		
e	1.27 BSC			0.050 BSC		
h	0.25	—	0.50	0.010	—	0.020
L	0.40	—	1.27	0.016	—	0.050
L1	1.04 REF			0.041 REF		
L2	0.25 BSC			0.010 BSC		
R	0.07	—	—	0.003	—	—
R1	0.07	—	—	0.003	—	—
q	0°	—	8°	0°	—	8°
q1	5°	—	15°	5°	—	15°
q2	0°	—	—	0°	—	—
D	8.65 BSC			0.341 BSC		
N	14					

Drawing No: POD-0000109

Revision: A

Ordering Information<sup>(1)</sup>

Part Number	Operation	Data Rate	Operating Temperature Range	Lead-Free	Package	Packaging Method	
XR33152ID-F	Half-duplex	250kbps	-40°C to 85°C	Yes <sup>(2)</sup>	8-pin SOIC	Tube	
XR33152IDTR-F			Tape and Reel				
XR33152HD-F			-40°C to 105°C			Tube	
XR33152HDTR-F			Tape and Reel				
XR33155ID-F	Half-duplex	1Mbps	-40°C to 85°C		8-pin SOIC	Tube	
XR33155IDTR-F			Tape and Reel				
XR33155HD-F			-40°C to 105°C			Tube	
XR33155HDTR-F			Tape and Reel				
XR33156ID-F	Full-duplex	20Mbps	-40°C to 85°C			14-pin SOIC	Tube
XR33156IDTR-F			Tape and Reel				
XR33156HD-F			-40°C to 105°C				Tube
XR33156HDTR-F			Tape and Reel				
XR33158ID-F	Half-duplex	20Mbps	-40°C to 85°C		8-pin SOIC		Tube
XR33158IDTR-F			Tape and Reel				
XR33158HD-F			-40°C to 105°C				Tube
XR33158HDTR-F			Tape and Reel				
XR33152IDEVB XR33152HDEVB XR33155IDEVB XR33155HDEVB XR33156IDEVB XR33156HDEVB XR33158IDEVB XR33158HDEVB	Evaluation Boards						

NOTE:

1. Refer to [www.exar.com/XR33152](http://www.exar.com/XR33152), [www.exar.com/XR33155](http://www.exar.com/XR33155), [www.exar.com/XR33156](http://www.exar.com/XR33156), [www.exar.com/XR33158](http://www.exar.com/XR33158) for most up-to-date Ordering Information.
2. Visit [www.exar.com](http://www.exar.com) for additional information on Environmental Rating.

## Revision History

Revision	Date	Description
1A	Jan 2016	Initial Release
2A	July 2016	Add XR33155, -40°C to 105°C parts, and Revision History.
2B	Jan 2017	Corrected XR33158 max temperature typo
2C	Feb 2018	Updated to MaxLinear logo. Updated format and Ordering Information. Moved ESD ratings to page 2.



**Corporate Headquarters:**  
5966 La Place Court  
Suite 100  
Carlsbad, CA 92008  
Tel.: +1 (760) 692-0711  
Fax: +1 (760) 444-8598  
[www.maxlinear.com](http://www.maxlinear.com)

**High Performance Analog:**  
1060 Rincon Circle  
San Jose, CA 95131  
Tel.: +1 (669) 265-6100  
Fax: +1 (669) 265-6101  
Email: [serialtechsupport@exar.com](mailto:serialtechsupport@exar.com)  
[www.exar.com](http://www.exar.com)

The content of this document is furnished for informational use only, is subject to change without notice, and should not be construed as a commitment by MaxLinear, Inc.. MaxLinear, Inc. assumes no responsibility or liability for any errors or inaccuracies that may appear in the informational content contained in this guide. Complying with all applicable copyright laws is the responsibility of the user. Without limiting the rights under copyright, no part of this document may be reproduced into, stored in, or introduced into a retrieval system, or transmitted in any form or by any means (electronic, mechanical, photocopying, recording, or otherwise), or for any purpose, without the express written permission of MaxLinear, Inc.

MaxLinear, Inc. does not recommend the use of any of its products in life support applications where the failure or malfunction of the product can reasonably be expected to cause failure of the life support system or to significantly affect its safety or effectiveness. Products are not authorized for use in such applications unless MaxLinear, Inc. receives, in writing, assurances to its satisfaction that: (a) the risk of injury or damage has been minimized; (b) the user assumes all such risks; (c) potential liability of MaxLinear, Inc. is adequately protected under the circumstances.

MaxLinear, Inc. may have patents, patent applications, trademarks, copyrights, or other intellectual property rights covering subject matter in this document. Except as expressly provided in any written license agreement from MaxLinear, Inc., the furnishing of this document does not give you any license to these patents, trademarks, copyrights, or other intellectual property.

Company and product names may be registered trademarks or trademarks of the respective owners with which they are associated.

© 2016 - 2018 MaxLinear, Inc. All rights reserved