

LEGEND  = KEY PRODUCT CHARACTERISTICS

REVISION HISTORY				
REV	DESCRIPTION	DATE	BY	CHG/No
0	FIRST ISSUE	30/10/08	M.H	8798

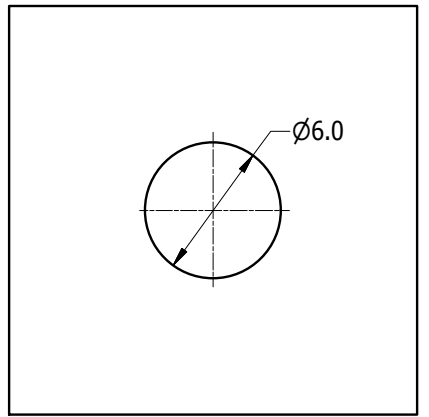

PANEL CUTOUT

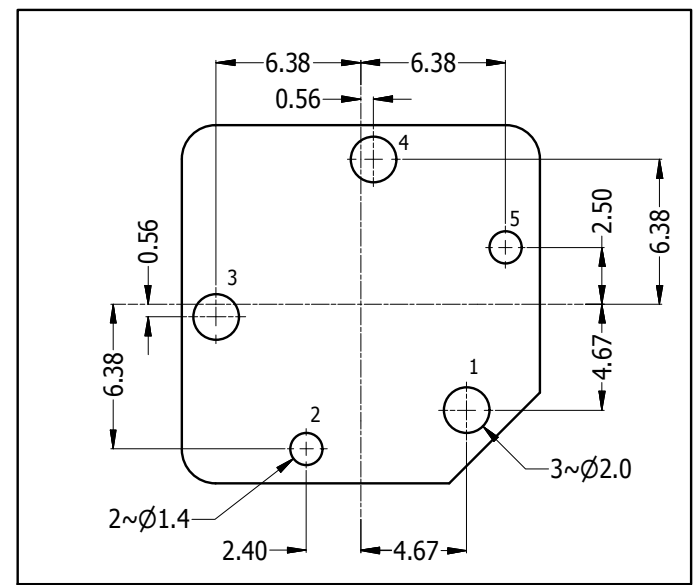
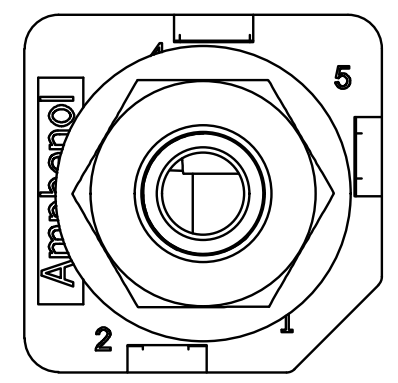
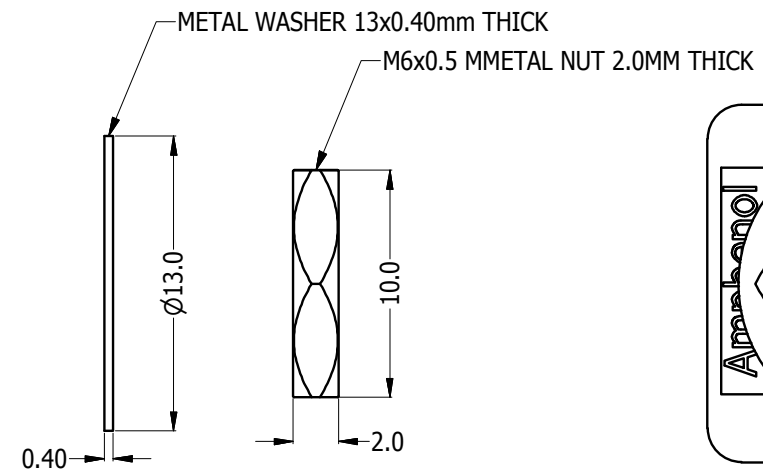
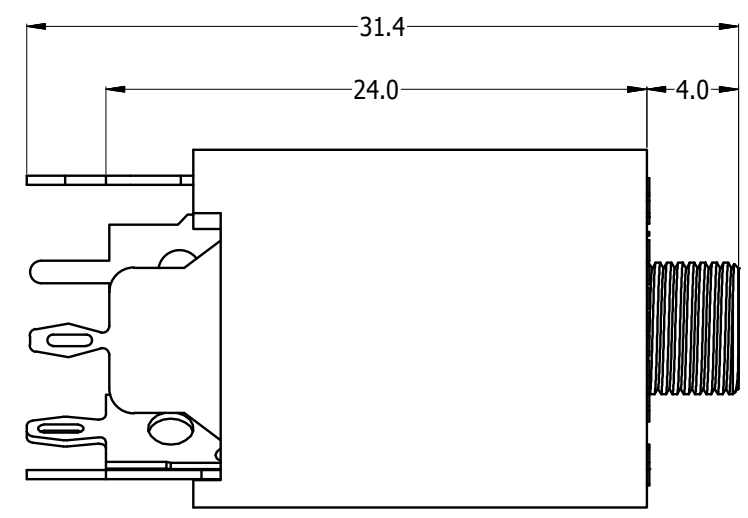
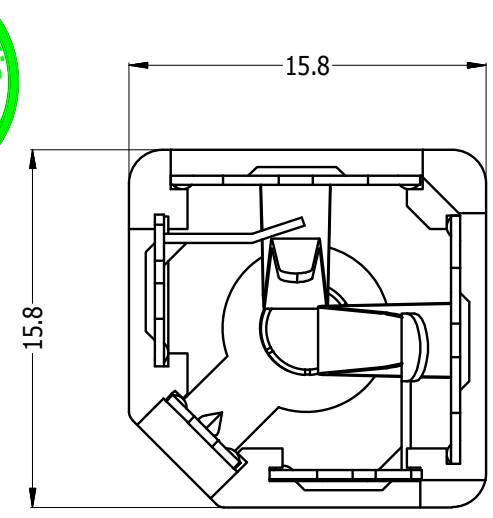
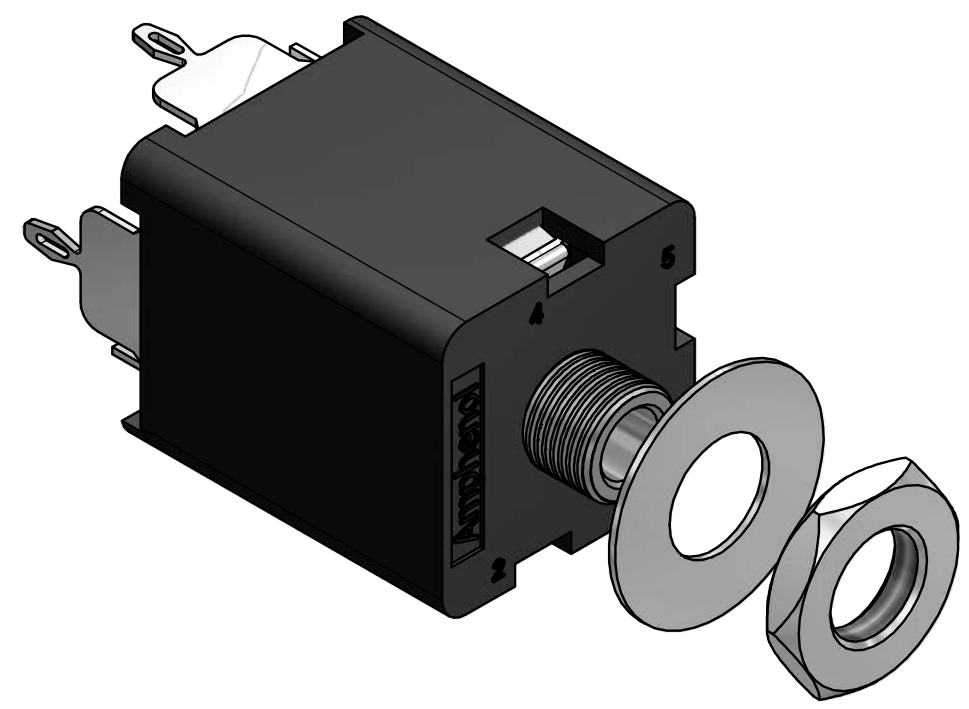

PCB LAYOUT
(CONNECTOR SIDE)

PART NUMBER	ACJM-MV35-2	ACJM-MV35-2S	ACJS-MV35-3	ACJS-MV35-3S	ACJS-MV35-5
SCHEMATIC					

NOTE: This connector is suitable for maximum 1.15mm panel thickness with Metal Washer & Nut

UNLESS OTHERWISE SPECIFIED TOLERANCE TO BE		THIS DOCUMENT IS THE PROPERTY OF AMPHENOL AUSTRALIA PTY. LTD. NO PART THEREOF MAY BE REPRODUCED AND USED WITHOUT THE PRIOR WRITTEN CONSENT OF THE OWNER				Amphenol Amphenol Australia Pty.Ltd, 2 Fiveways Blvd, Keysborough, VIC 3173	
LINEAR	ANGULAR	MATERIAL: REFER TO COMPONENTS	DRN: B.Z	DATE: 25/04/08	TITLE: 3.5mm JACK VERTICAL CUSTOMER DRAWING		PART No: SEE CHART
X ±0.5	X° ±1	FINISH: REFER TO COMPONENTS	CKD: M.H	DATE: 29/10/08	DRAWING NO. 55010544-001-5		SHEET 1/1
X.X ±0.1	X.X° ±30'	DO NOT SCALE	APP'D: P.M	DATE: 29/10/08	CAD FILE 55010544001110		
X.XX ±0.05	X.XX° ±15'	DIMENSIONS IN MILLIMETRES	SCALE: 3:1	SIZE: A3			