

PART NUMBER	REVISION	DESCRIPTION	FEED TYPE
2150302-1	G	FINE CRIMP HEIGHT ADJUST	MECHANICAL
2150302-2	H	FINE CRIMP HEIGHT ADJUST	PNEUMATIC
7-2150302-1	G	MECHANICAL AND CRIMP TOOLING KIT	MECHANICAL
7-2150302-2	H	PNEUMATIC AND CRIMP TOOLING KIT	PNEUMATIC
7-2150302-7	B	CRIMP TOOLING KIT	-

ATLANTIC VERSION TERMINATOR INTERFACE ADAPTER

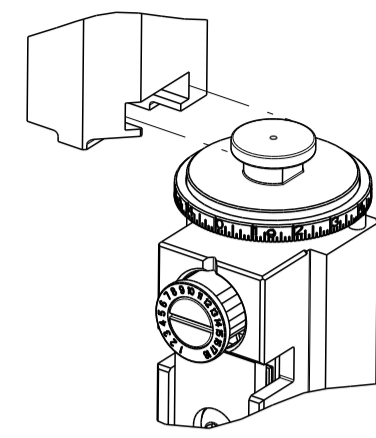

APPLICATOR DATA		
CRIMP	SIZE	TYPE
WIRE	2.29 mm [.090]	F
INSUL	3.56 mm [.140]	F

APPLICATOR INSTRUCTIONS 408-35043

TERMINAL DATA: TE TERMINAL		TE CRIMP SPECIFICATION	
TERMINAL NAME: .250 SRS FASTIN-FASTON REC.			
WIRE STRIP LENGTH		INSULATION DIAMETER RANGE	
4.37-5.13 mm [.172-.202 IN]		∅2.30-3.30 mm [.091-.130 IN]	
TERMINAL APPLICATION SPECIFICATION	114-18022		
TERMINALS APPLIED			
TE TERMINAL	TE TERMINAL	TE TERMINAL	TE TERMINAL
160558-3	5-160558-2	5-160558-8	6-160558-0
5-160558-1	5-160558-3	5-160558-9	160825-2

WIRE SIZE	CRIMP HEIGHT mm [INCH]	CRIMP HEIGHT REFERENCE SETTING
1.50mm2	1.75 +/- 0.05 [.069 +/- .002]	6.5
1.00mm2 +0.35mm2	1.61 +/- 0.05 [.063 +/- .002]	8.2
1.00mm2	1.59 +/- 0.05 [.063 +/- .002]	8.5
0.75mm2	1.51 +/- 0.05 [.059 +/- .002]	9.4
0.50mm2	1.43 +/- 0.05 [.056 +/- .002]	10.4

- B**
- RECOMMENDED SPARE PARTS
 - REFER TO SUPPLIED INSTRUCTION SHEET FOR CLEANING, LUBRICATION AND STORAGE OF APPLICATOR.
 - APPLY PART NUMBER 2-23419-6 LOCTITE TO THREADS OF ITEM 242. APPLY PART NUMBER 1-23419-5 LOCTITE TO THREADS OF ITEM 50.
 - CRIMP HEIGHT REFERENCE SETTING WAS THE SETTING USED WHEN THE APPLICATOR WAS QUALIFIED AT THE FACTORY. ADJUSTMENT MAY BE NECESSARY WHEN RUNNING APPLICATOR IN THE FIELD.
 - UNLESS SPECIFIED OTHERWISE TORQUE VALUES SHALL BE USED PER DOCUMENT, 101-35000.

***WARNING**
ON INSTALLATION, SET WIRE DISC TO CRIMP HEIGHT REFERENCE SETTING FOR LARGEST WIRE SIZE. CRIMP HEIGHT REFERENCE SETTINGS GREATER THAN THE VALUE SHOWN MAY CAUSE DAMAGE TO THE CRIMP TOOLING. REFER TO THE INSTRUCTION SHEET FOR PROPER SETUP AND ADJUSTMENTS.

LOC	DIST	REVISIONS					
A	66	P	LTN	DESCRIPTION	DATE	DWN	APVD
		F		ECR-14-005632	15APR2014	RK	GB
		F1		ECR-16-000970	22JAN2016	KH	TE
		G		ECR-18-015646	04OCT2018	TB	TE
		H		ECR-21-005521	17MAY2021	TB	RK

-	1	-	1	-	2119641-1	FEED CAM, AIR FEED	248	
-	1	1	1	1	2119082-9	CAM, SNAIL, INSULATION ADJUSTMENT	244	
-	1	1	1	1	2079764-1	WASHER, WAVE SPRING, CREST-TO-CREST	243	
-	1	1	1	1	2119083-1	RETAINER, INSULATION DIAL	242	
-	-	1	-	1	2119580-1	MECHANICAL FEED ASSEMBLY	239	
-	1	-	1	-	2844940-3	AIR FEED MODULE	238	
-	1	1	1	1	1-18028-0	WASHER, FLAT, REG M8	192	
-	1	1	1	1	6-993111-6	PIN, SLOTTED SPRING 3.0 X 14.0	177	
-	1	1	1	1	8-22280-7	SPRING, COMPRESSION	176	
-	1	1	1	1	1752353-2	GUIDE PIN,HOLDDOWN	175	
-	1	1	1	1	1901680-2	GUIDE PIN,HOLDDOWN	174	
-	REF	REF	REF	REF	994970-2	COUNTER, MAGNETIC	164	
-	1	1	1	1	455888-5	SPACER, CRIMPER	82	
-	1	1	1	1	2119791-9	DEPRESSOR, WIRE	73	
-	1	1	1	1	1803607-4	DOCUMENTATION PACKAGE	71	
-	2	2	2	2	2-18032-2	SCR, SET, FLT PNT, M3 X 10.0	70	
-	1	1	1	1	2119740-1	TAG, IDENTIFICATION	67	
-	2	2	2	2	2168078-1	SCREW, DRIVE, RH, RoHS, 2 x .188	66	
-	1	1	1	1	1901681-1	HOLDDOWN, TERMINAL	65	
-	2	2	2	2	2168400-5	SHCS, LOW HEAD, RoHS, M4 X 20	64	
-	1	1	1	1	2168083-2	SCR, SKT HD CAP, RoHS, M4 X 8.0	60	
-	1	1	1	1	5-18022-5	SCR, HEX HD CAP, M4 X 6.0	59	
-	-	1	-	1	2063961-1	FEED FINGER	58	
-	3	3	3	3	2168400-4	SHCS, LOW HEAD, RoHS, M4 X 8	57	
-	2	2	2	2	2168083-3	SCR, SKT HD CAP, RoHS, M4 X 12.0	56	
-	2	2	2	2	5018030-1	NUT, HEX, REG, RoHS, M3	54	
-	2	2	2	2	986965-8	NUT, LOCK, HEX, TORQUE (M4)	53	
-	1	1	1	1	1-5018030-0	NUT, HEX, REG, RoHS, M3.5	52	
-	1	-	1	-	2063961-1	FEED FINGER	51	
-	1	1	1	1	1-1752354-2	STANDOFF,HOLD-DOWN	50	
-	1	2	1	2	18023-9	SCR, SKT HD CAP M4 X 6.0	49	
-	-	1	-	1	2119652-1	FEED CAM, PRE FEED	48	
-	-	1	-	1	2119653-1	FEED CAM, POST FEED	47	
-	1	1	1	1	2119655-5	APPLICATOR BASIC ASSEMBLY, EF	46	
-	1	1	1	1	1803517-1	RAM ASSEMBLY, EF ATLANTIC	44	
-	1	1	1	1	1803602-1	SCR, BHSC, RoHS (M8 X 25)	41	
-	7	7	7	7	1-18028-2	WASHER, FLAT, REG M4	33	
-	2	2	2	2	2168083-9	SCR, SKT HD CAP, RoHS, M4 X 20	31	
-	2	2	2	2	2168083-2	SCR, SKT HD CAP, RoHS, M4 X 8.0	29	
-	1	1	1	1	240639-1	STRIPPER (MACHINING)	27	
-	2	2	2	2	1-2168083-5	SCR, SKT HD CAP, RoHS, M4 X 30	25	
-	1	1	1	1	1752371-9	PLATE, STRIP GUIDE	24	
-	1	1	1	1	240825-1	PLATE, STRIP HOLD DOWN	23	
-	2	2	2	2	2-22281-3	SPRING, COMPRESSION	22	
-	1	1	1	1	1803292-4	DRAG	20	
-	2	2	2	2	1901259-5	GUIDE, LOWER STRIP	18	
-	4	4	4	4	1-2079383-1	SCR, BHSC, RoHS (M6 X 12)	17	
-	1	1	1	1	6-240641-4	SPACER	16	
-	1	1	1	1	1752360-1	SPACER,HOLD-DOWN	13	
-	1	1	1	1	240833-3	PLATE, REAR SHEAR	11	
-	-	-	-	-	-	-	10	
-	1	1	1	1	690482-3	PLATE, FRONT SHEAR	9	
-	1	2	2	1	1	2-1333217-7	ANVIL, EF .090	8
-	1	1	1	1	1	1-2217206-4	BLADE, SLUG	7
-	-	-	-	-	-	-	6	
-	1	1	1	1	1	1-240641-0	SPACER	5
-	1	1	1	1	1	238011-2	BLOCK, CRIMPER SPACER	4
-	1	2	2	1	1	1803017-9	CRIMPER, INSULATION F	3
-	1	1	1	1	1	455888-4	SPACER, CRIMPER	2
-	1	2	2	1	1	1-456406-2	CRIMPER, WIRE PREMIUM	1
-	77	72	71	2	-1	PART NO	DESCRIPTION	ITEM NO

ATLANTIC VERSION
Shown on sheets 1 of 4 & 2 of 4
(Pacific version shown on sheets 3 of 4 & 4 of 4)

DIMENSIONS:		TOLERANCES UNLESS OTHERWISE SPECIFIED:		MATERIAL:		FINISH:		WEIGHT:		SCALE:		SHEET:		REV:	
mm	0 PLC ±	1 PLC ±	2 PLC ±	3 PLC ±	4 PLC ±	ANGLES	FINISH			A1	00779	2150302	1	4	H

Customer Accessible Production Drawing

LOC	DIST	REVISIONS					
A	66	P	LTM	DESCRIPTION	DATE	OWN	APVD
		-	-	SEE SHEET 1	-	-	-

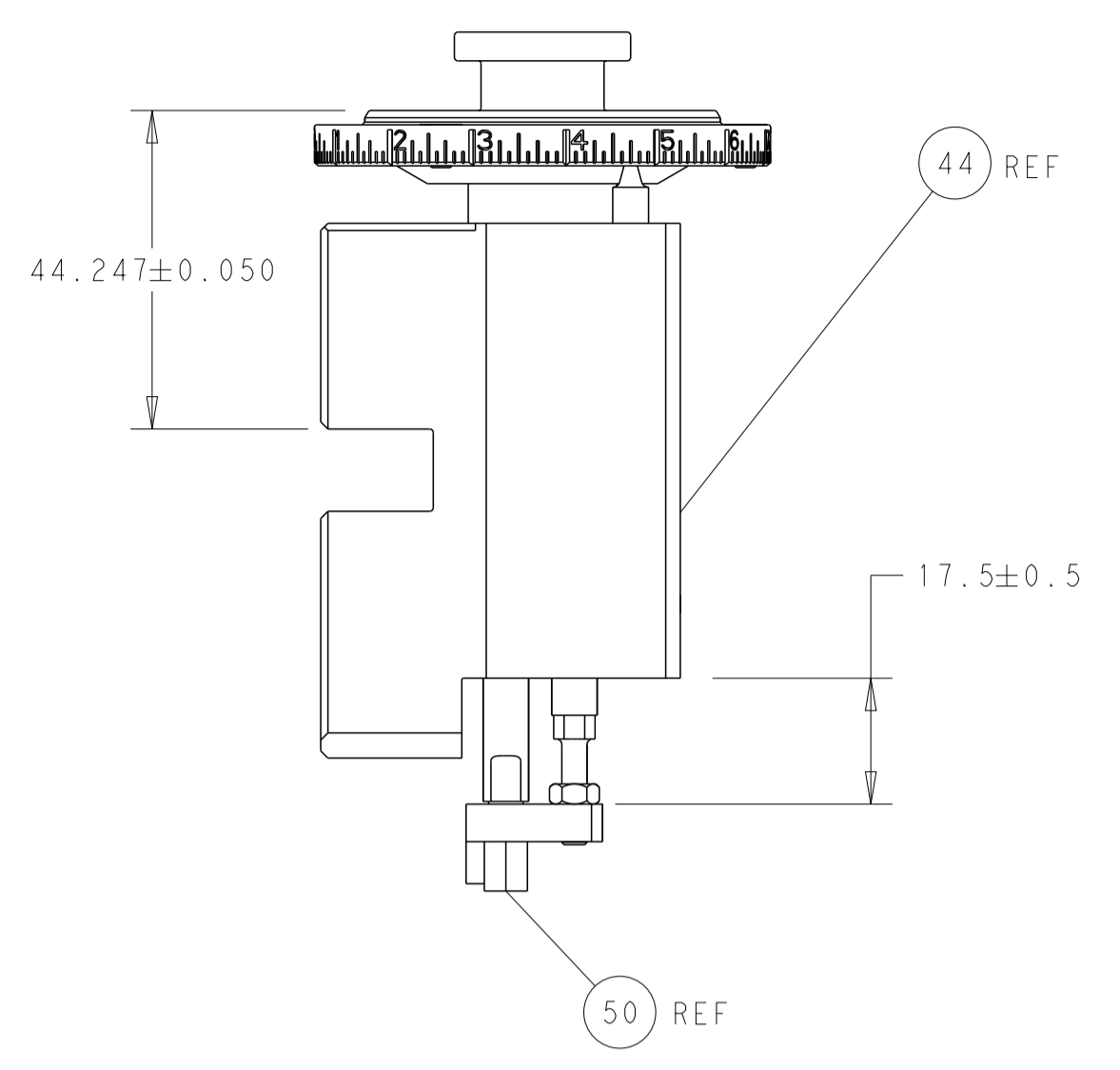

RAM AND HOLDDOWN SET-UP

FEED TYPE
MECHANICAL

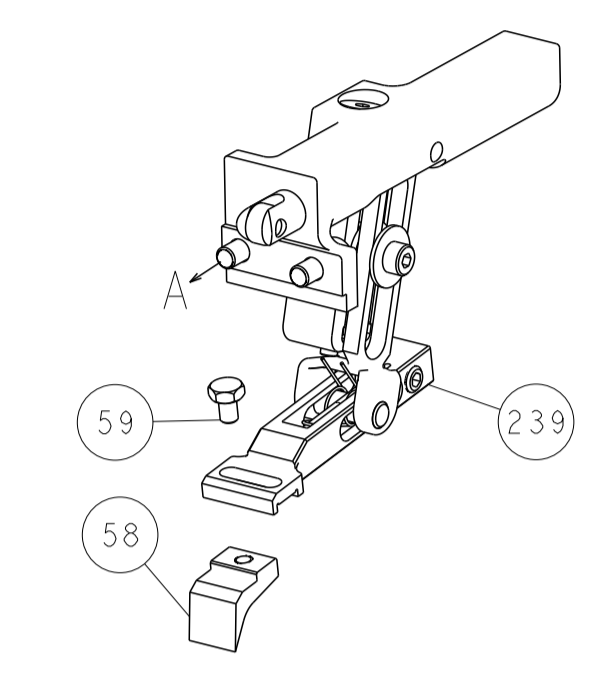

PNEUMATIC

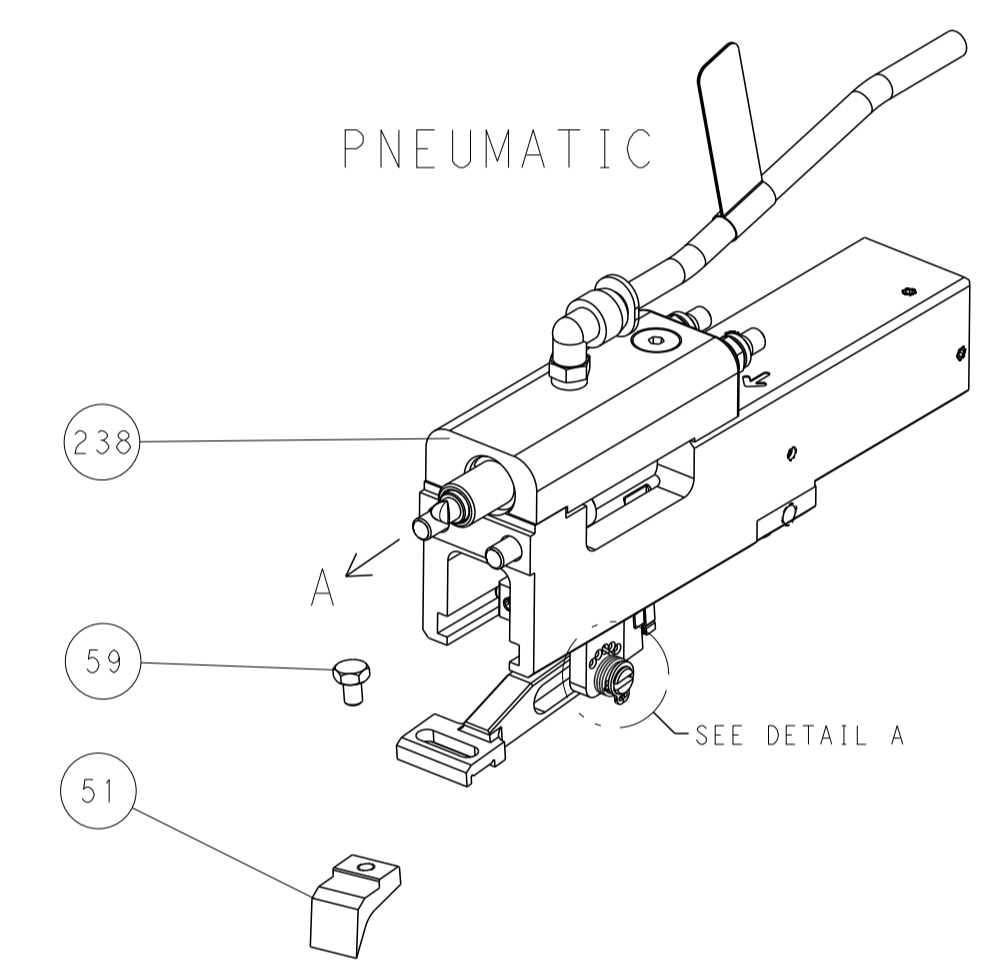

FEED SPRING
SETTING POSITION

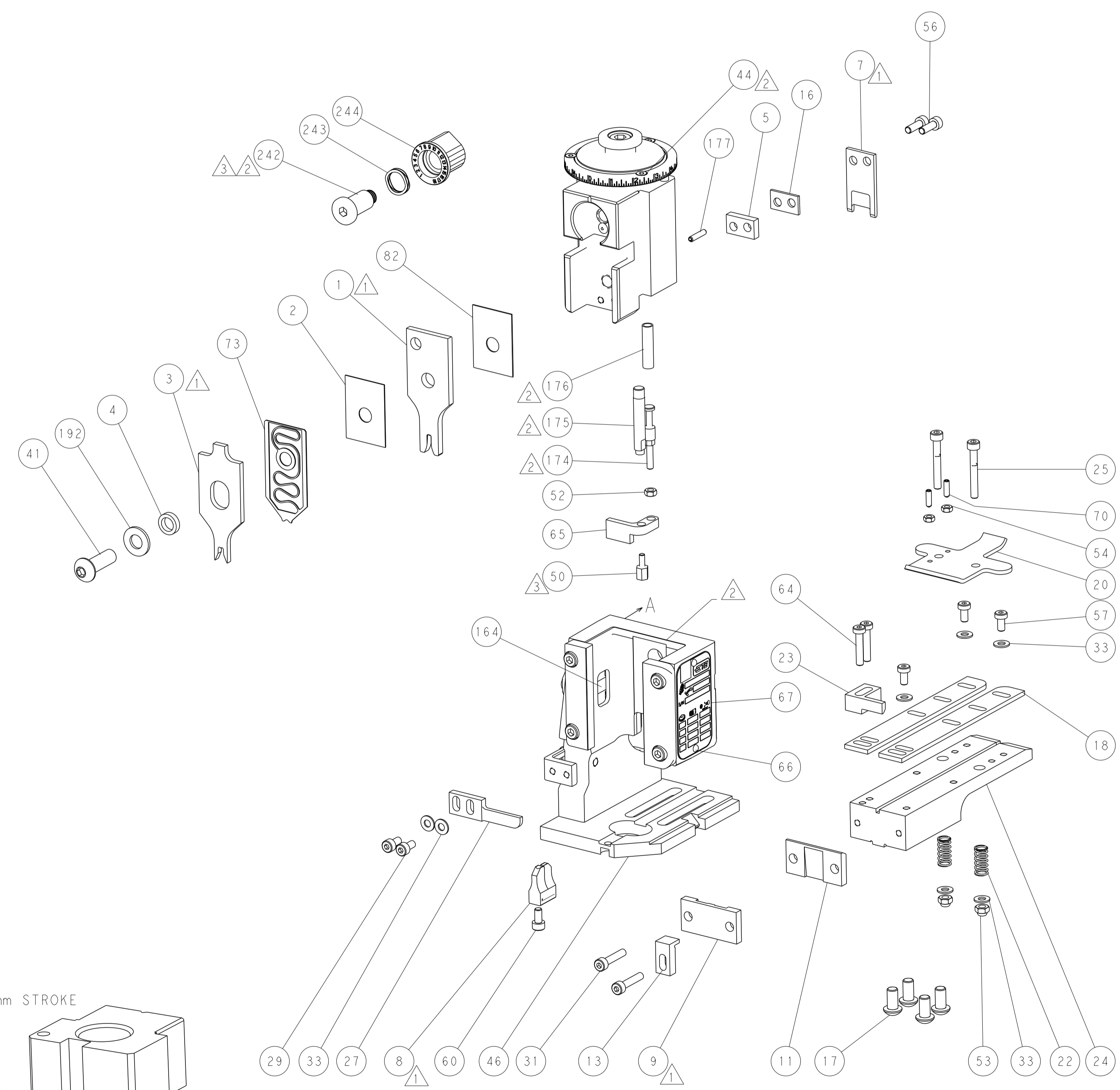
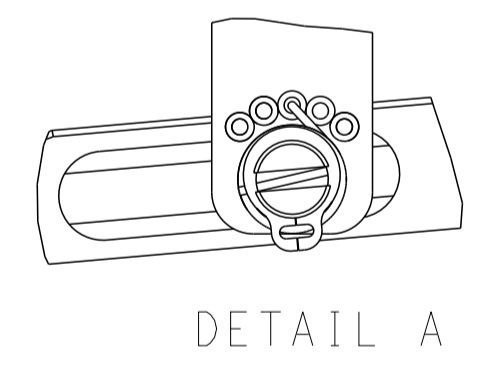

CAM POSITIONS

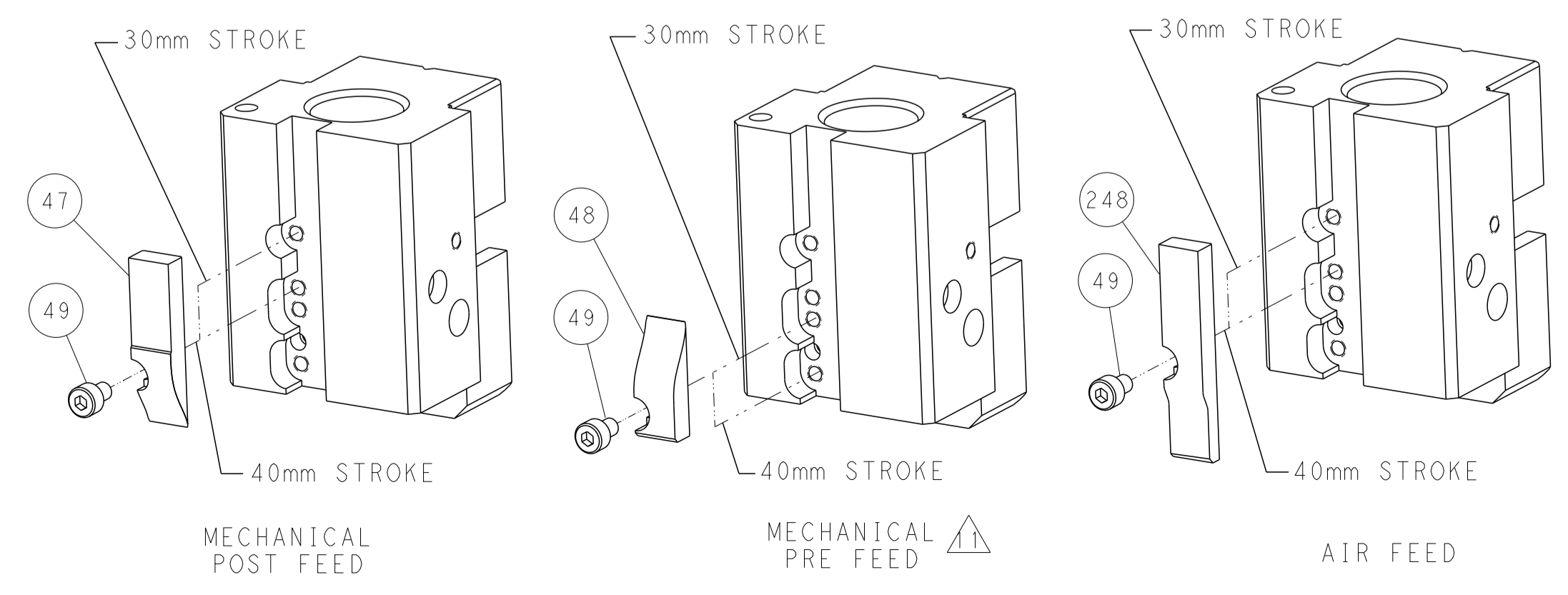

ATLANTIC VERSION
 Shown on sheets 1 of 4 & 2 of 4
 (Pacific version shown on sheets 3 of 4 & 4 of 4)

<small>THIS DRAWING IS UNPUBLISHED. RELEASED FOR PUBLICATION BY TYCO ELECTRONICS CORPORATION. ALL RIGHTS RESERVED.</small>		DWN: Y. YIN 16NOV2012 CHK: G. BIALEY 16NOV2012 APVD: S. XI 16NOV2012	TE Connectivity Harrisburg, PA 17105-3608
DIMENSIONS: mm TOLERANCES UNLESS OTHERWISE SPECIFIED: 0 PLC ± 1 PLC ± 2 PLC ± 3 PLC ± 4 PLC ± ANGLES ± FINISH		NAME: Ocean End Feed Applicator PRODUCT SPEC: APPLICATION SPEC: WEIGHT:	SIZE: A1 CAGE CODE: 00779 DRAWING NO: C=2150302 RESTRICTED TO:
MATERIAL:		SCALE: 1:1 SHEET: 2 of 4 REV: H	Customer Accessible Production Drawing

PART NUMBER	REVISION	DESCRIPTION	FEED TYPE
2-2150302-1	G	FINE CRIMP HEIGHT ADJUST	MECHANICAL
2-2150302-2	H	FINE CRIMP HEIGHT ADJUST	PNEUMATIC
7-2150302-7	B	CRIMP TOOLING KIT	-

PACIFIC VERSION TERMINATOR
 INTERFACE ADAPTER

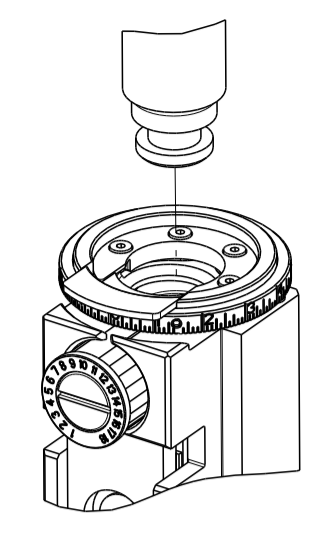

APPLICATOR DATA		
CRIMP	SIZE	TYPE
WIRE	2.29 mm (.090)	F
INSUL	3.56 mm (.140)	F
APPLICATOR INSTRUCTIONS 408-35043		

TERMINAL DATA: TE TERMINAL		TE CRIMP SPECIFICATION	
TERMINAL NAME: .250 SRS FASTIN-FASTON REC.			
WIRE STRIP LENGTH 4.37-5.13 mm (.172-.202 IN)		INSULATION DIAMETER RANGE Ø2.30-3.30 mm (.091-.130 IN)	
TERMINAL APPLICATION SPECIFICATION 114-18022			
TERMINALS APPLIED			
TE TERMINAL	TE TERMINAL	TE TERMINAL	TE TERMINAL
160558-3	5-160558-2	5-160558-8	6-160558-0
5-160558-1	5-160558-3	5-160558-9	160825-2

WIRE SIZE	CRIMP HEIGHT mm [INCH]	CRIMP HEIGHT REFERENCE SETTING
1.50mm2	1.75 +/- 0.05 [.069 +/- .002]	6.5
1.00mm2 +0.35mm2	1.61 +/- 0.05 [.063 +/- .002]	8.2
1.00mm2	1.59 +/- 0.05 [.063 +/- .002]	8.5
0.75mm2	1.51 +/- 0.05 [.059 +/- .002]	9.4
0.50mm2	1.43 +/- 0.05 [.056 +/- .002]	10.4

- RECOMMENDED SPARE PARTS
- REFER TO SUPPLIED INSTRUCTION SHEET FOR CLEANING, LUBRICATION AND STORAGE OF APPLICATOR.
- APPLY PART NUMBER 2-23419-6 LOCTITE TO THREADS OF ITEM 242. APPLY PART NUMBER 1-23419-5 LOCTITE TO THREADS OF ITEM 50.
- CRIMP HEIGHT REFERENCE SETTING WAS THE SETTING USED WHEN THE APPLICATOR WAS QUALIFIED AT THE FACTORY. ADJUSTMENT MAY BE NECESSARY WHEN RUNNING APPLICATOR IN THE FIELD.
- 5. UNLESS SPECIFIED OTHERWISE TORQUE VALUES SHALL BE USED PER DOCUMENT, 101-35000.

***WARNING**
 ON INSTALLATION, SET WIRE DISC TO CRIMP HEIGHT REFERENCE SETTING FOR LARGEST WIRE SIZE. CRIMP HEIGHT REFERENCE SETTINGS GREATER THAN THE VALUE SHOWN MAY CAUSE DAMAGE TO THE CRIMP TOOLING. REFER TO THE INSTRUCTION SHEET FOR PROPER SETUP AND ADJUSTMENTS.

LOC	DIST	REVISIONS					
A	66	P	LTN	DESCRIPTION	DATE	OWN	APVD
-	-	-	-	SEE SHEET 1	-	-	-

-	1	1	2119082-9	CAM, SNAIL, INSULATION ADJUSTMENT	244	
-	1	1	2079764-1	WASHER, WAVE SPRING, CREST-TO-CREST	243	
-	1	1	2119083-1	RETAINER, INSULATION DIAL	242	
-	-	1	2119580-1	MECHANICAL FEED ASSEMBLY	239	
-	1	-	2844940-3	AIR FEED MODULE	238	
-	1	1	1-18028-0	WASHER, FLAT, REG M8	192	
-	4	4	2079383-9	SCR, BHSC, RoHS (M6 X 20)	186	
-	1	1	6-993111-6	PIN, SLOTTED SPRING 3.0 X 14.0	177	
-	1	1	8-22280-7	SPRING, COMPRESSION	176	
-	1	1	1752353-2	GUIDE PIN,HOLDDOWN	175	
-	1	1	1901680-2	GUIDE PIN,HOLDDOWN	174	
-	REF	REF	994970-2	COUNTER, MAGNETIC	164	
-	1	-	2119641-2	FEED CAM, AIR FEED	152	
-	1	1	2168083-8	SCR, SKT HD CAP, RoHS, M4 X 16	144	
-	-	1	2119653-2	FEED CAM, POST FEED	142	
-	1	1	2119655-6	APPLICATOR BASIC ASSEMBLY, EF	141	
-	1	1	1803518-1	RAM ASSEMBLY, EF PACIFIC	140	
-	1	1	455888-5	SPACER, CRIMPER	82	
-	1	1	2119791-9	DEPRESSOR, WIRE	73	
-	1	1	1803607-4	DOCUMENTATION PACKAGE	71	
-	2	2	2-18032-2	SCR, SET, FLT PNT, M3 X 10.0	70	
-	1	1	2119740-1	TAG, IDENTIFICATION	67	
-	2	2	2168078-1	SCREW, DRIVE, RH, RoHS, 2 x .188	66	
-	1	1	1901681-1	HOLDDOWN, TERMINAL	65	
-	2	2	2168400-5	SHCS, LOW HEAD, RoHS, M4 X 20	64	
-	1	1	5-18022-5	SCR, HEX HD CAP, M4 X 6.0	59	
-	-	1	2063961-1	FEED FINGER	58	
-	3	3	2168400-4	SHCS, LOW HEAD, RoHS, M4 X 8	57	
-	2	2	2168083-3	SCR, SKT HD CAP, RoHS, M4 X 12.0	56	
-	2	2	5018030-1	NUT, HEX, REG, RoHS, M3	54	
-	2	2	986965-8	NUT, LOCK, HEX, TORQUE (M4)	53	
-	1	1	1-5018030-0	NUT, HEX, REG, RoHS, M3.5	52	
-	1	-	2063961-1	FEED FINGER	51	
-	1	1	1-1752354-2	STANDOFF,HOLD-DOWN	50	
-	1	2	18023-9	SCR, SKT HD CAP M4 X 6.0	49	
-	-	1	2119652-1	FEED CAM, PRE FEED	48	
-	1	1	1803602-1	SCR, BHSC, RoHS (M8 X 25)	41	
-	7	7	1-18028-2	WASHER, FLAT, REG M4	33	
-	2	2	2168083-9	SCR, SKT HD CAP, RoHS, M4 X 20	31	
-	2	2	2168083-2	SCR, SKT HD CAP, RoHS, M4 X 8.0	29	
-	1	1	240639-1	STRIPPER (MACHINING)	27	
-	2	2	1-2168083-5	SCR, SKT HD CAP, RoHS, M4 X 30	25	
-	1	1	1752371-9	PLATE, STRIP GUIDE	24	
-	1	1	240825-1	PLATE, STRIP HOLD DOWN	23	
-	2	2	2-22281-3	SPRING, COMPRESSION	22	
-	1	1	1803292-4	DRAG	20	
-	2	2	1901259-5	GUIDE, LOWER STRIP	18	
-	1	1	6-240641-4	SPACER	16	
-	1	1	1752360-1	SPACER,HOLD-DOWN	13	
-	1	1	240833-3	PLATE, REAR SHEAR	11	
-	-	-	-	-	10	
-	1	1	690482-3	PLATE, FRONT SHEAR	9	
-	1	1	2-1333217-7	ANVIL, EF .090	8	
-	1	1	1-2217206-4	BLADE, SLUG	7	
-	-	-	-	-	6	
-	1	1	1-240641-0	SPACER	5	
-	1	1	238011-2	BLOCK, CRIMPER SPACER	4	
-	1	1	1803017-9	CRIMPER, INSULATION F	3	
-	1	1	455888-4	SPACER, CRIMPER	2	
-	1	1	1-456406-2	CRIMPER, WIRE PREMIUM	1	
-	77	22	21	PART NO	DESCRIPTION	ITEM NO

PACIFIC VERSION
 Shown on sheets 3 of 4 & 4 of 4
 (Atlantic version shown on sheets 1 of 4 & 2 of 4)

DIMENSIONS: mm		TOLERANCES UNLESS OTHERWISE SPECIFIED:		DWN Y. YIN 16NOV2012		CHK G. BAILEY 16NOV2012		APVD S. XI 16NOV2012		NAME	
0 PLC ±		1 PLC ±		2 PLC ±		3 PLC ±		4 PLC ±		SIZE CAGE CODE DRAWING NO RESTRICTED TO	
MATERIAL		FINISH		WEIGHT		A1 00779		C=2150302		SCALE 1:1 SHEET 3 OF 4 REV H	
Customer Accessible Production Drawing										Customer Accessible Production Drawing	

LOC	DIST	REV	DESCRIPTION	DATE	OWN	APVD
A	66		SEE SHEET 1			

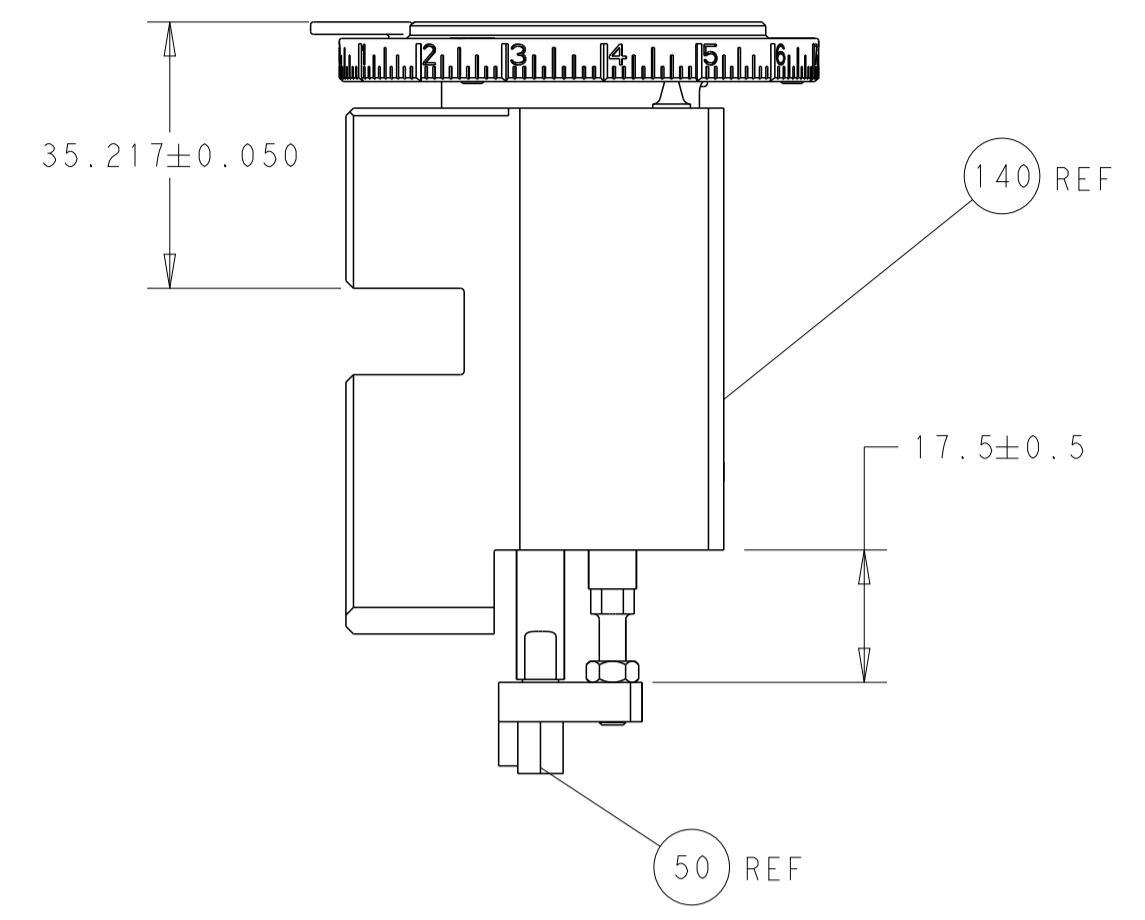

RAM AND HOLDDOWN SET-UP

FEED TYPE
MECHANICAL

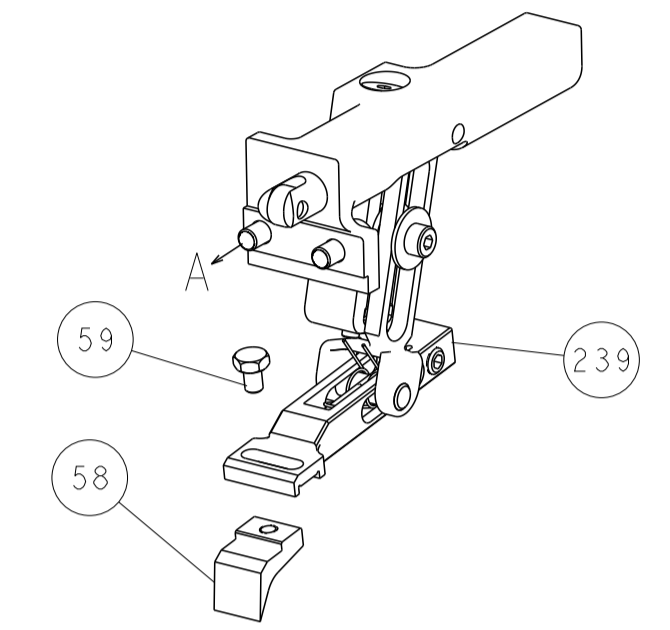

PNEUMATIC

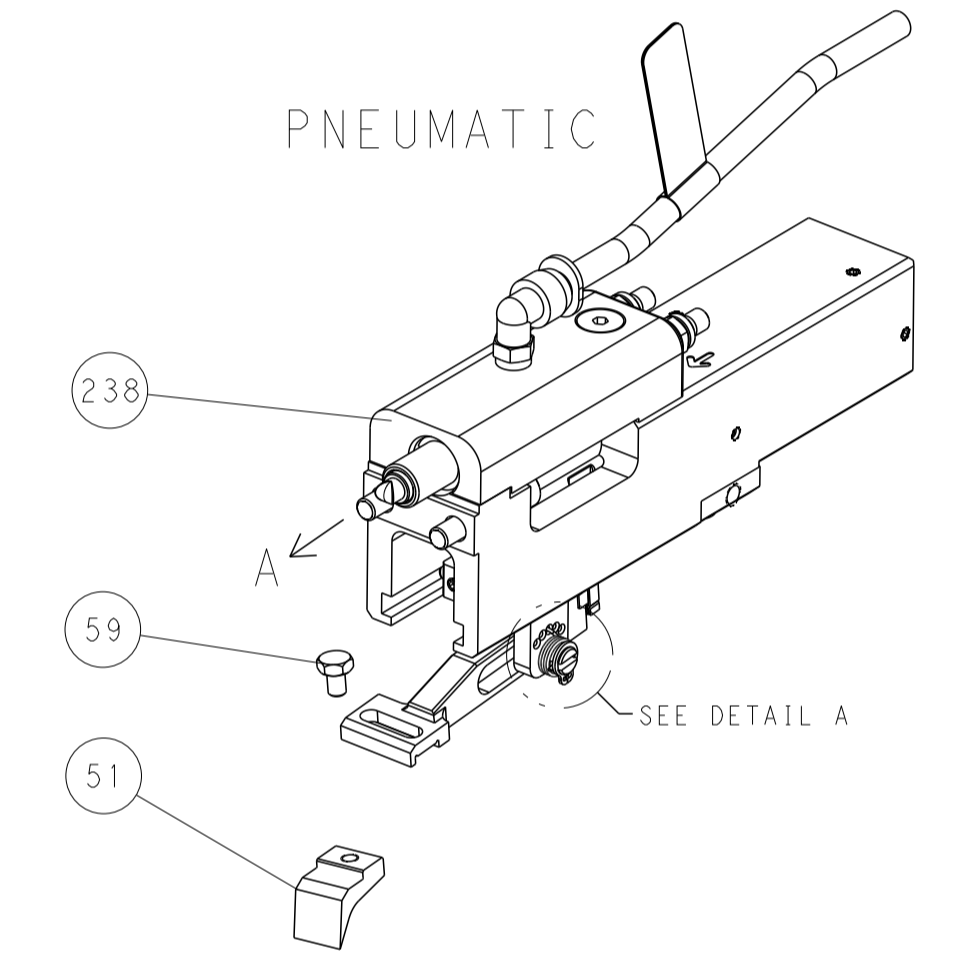

FEED SPRING
SETTING POSITION

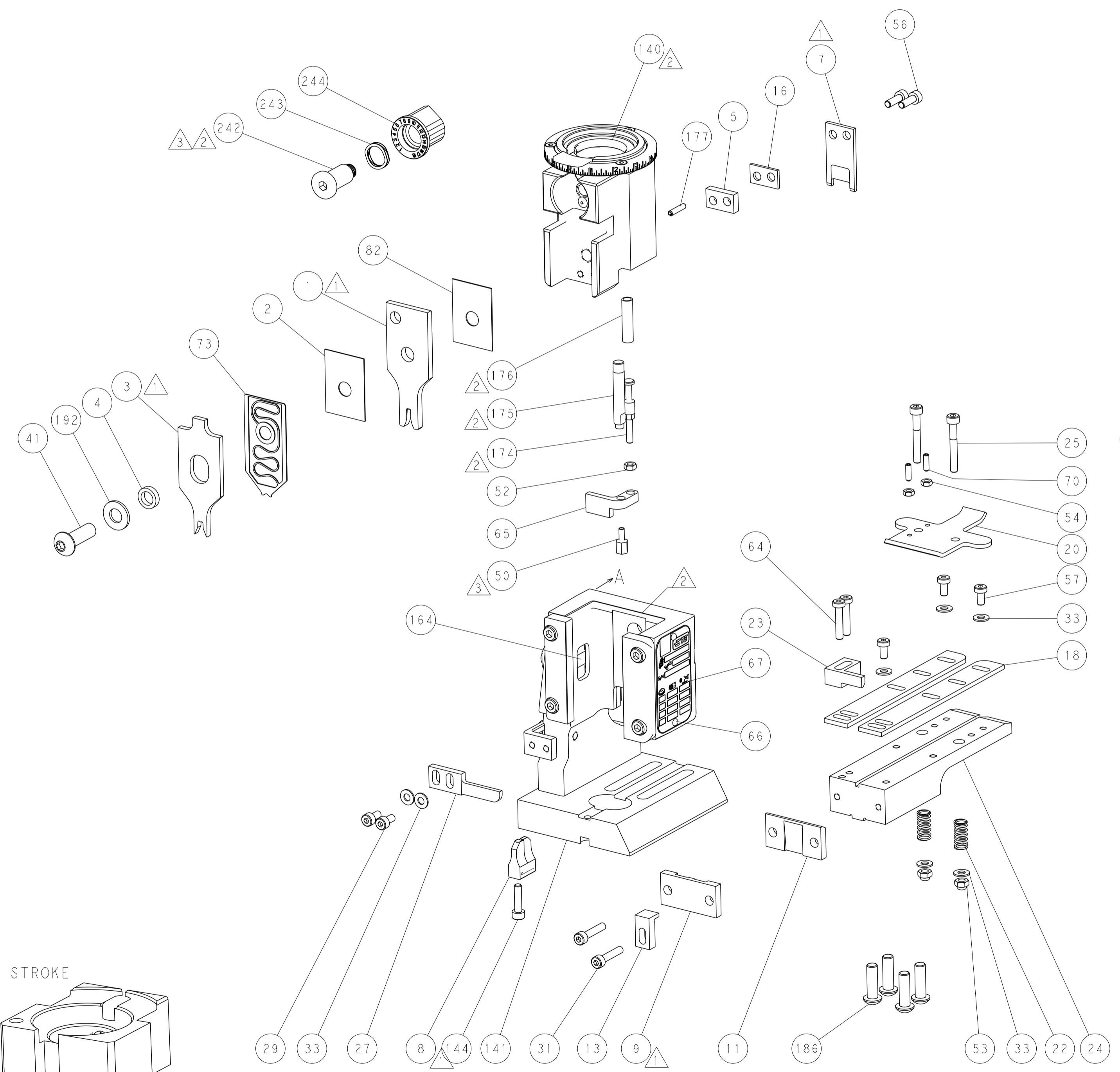
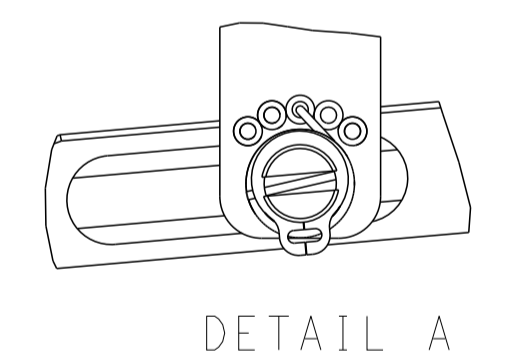

CAM POSITIONS

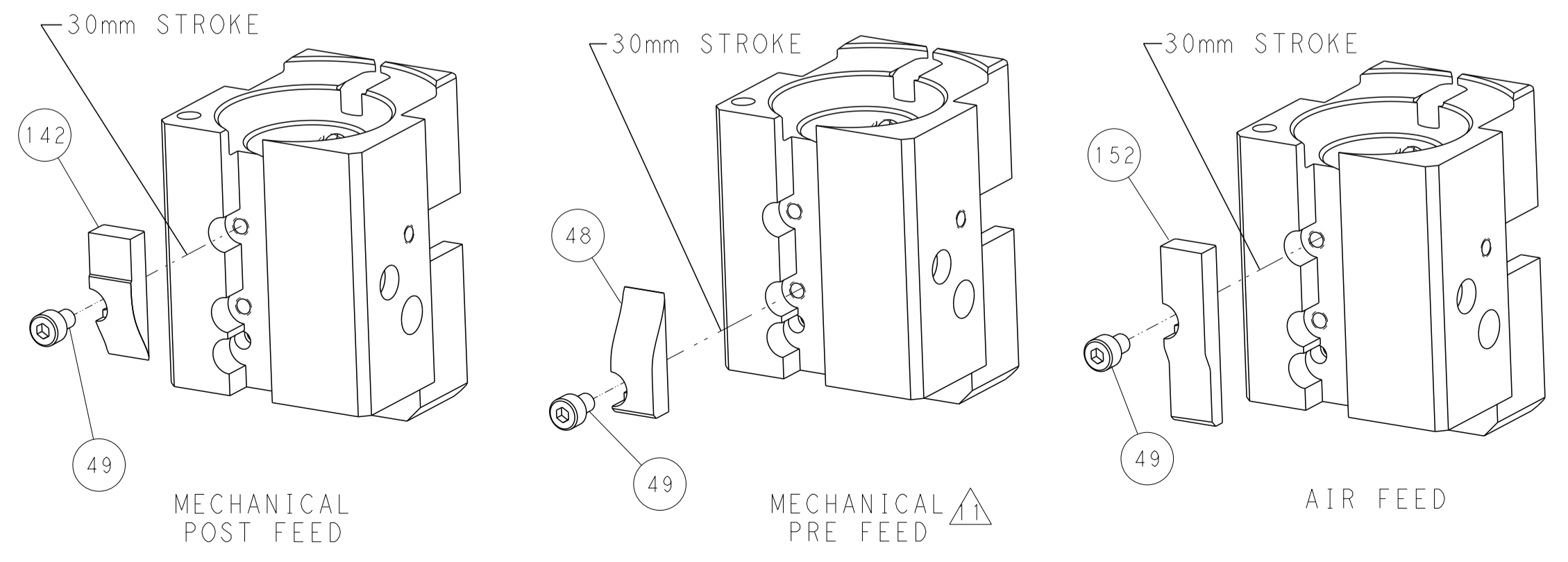

PACIFIC VERSION
 Shown on sheets 3 of 4 & 4 of 4
 (Atlantic version shown on sheets 1 of 4 & 2 of 4)

DIMENSIONS: mm 		TOLERANCES UNLESS OTHERWISE SPECIFIED: 0 PLC ± 1 PLC ± 2 PLC ± 3 PLC ± 4 PLC ± ANGLES ± FINISH		DWN Y. YIN 16NOV2012 CHK G. BAILEY 16NOV2012 APVD S. XI 16NOV2012 NAME PRODUCT SPEC APPLICATION SPEC WEIGHT SCALE 1:1 SHEET 4 OF 4 REV H		STE TE Connectivity Harrisburg, PA 17105-3608 Ocean End Feed Applier CAGE CODE 00779 DRAWING NO. 2150302 RESTRICTED TO	
-----------------------	--	---	--	---	--	---	--