

PART NUMBER	REV	FIRST USED
687944-1	J	122500-1
687944-2	J	565435-5

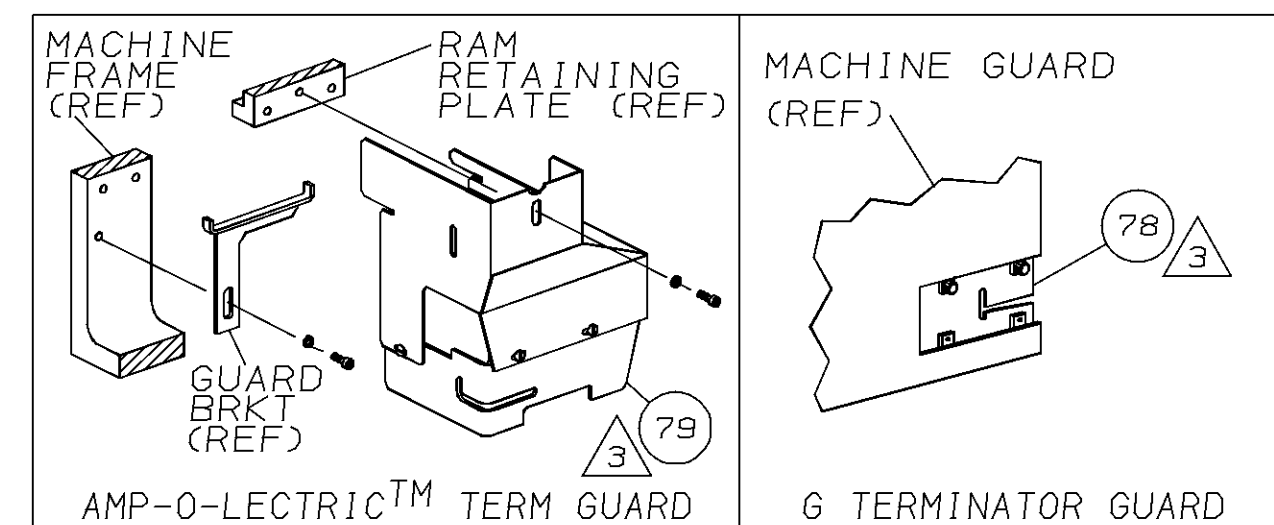

TERMINAL NAME: .312 FASTON™ RECEPTACLE		42663	
CRIMPING DATA			
PAD LTR	CRIMP HEIGHT	WIRE SIZE	
A	.092 ± .002 [2.34 ± 0.05mm]	12	
B	.084 ± .002 [2.13 ± 0.05mm]	(2) 16	
C	.078 ± .002 [1.98 ± 0.05mm]	14 OR (16 & 18)	
D	.069 ± .002 [1.75 ± 0.05mm]	16	
CRIMP	SIZE	TYPE	
WIRE	.110 [2.79mm]	F	
INSUL	.250 [6.35mm]	F	
WIRE STRIP LENGTH		TERM APPL	SPEC
-		-	-
FEED		APPL INSTRUCTION	SET UP GAGE
.966		408-8039	458638-1
LAYOUT		200	

LEADMAKER & BENCH MODEL G		MECH POST FEED				
BENCH MODEL K		MECH POST FEED				
REF	REF	-	A	22594-8	NUT, HEX	70
REF	REF	-	B	240628-1	PLATE, ADJ	69
REF	REF	-	B	240626-1	SHAFT, PIVOT	68
REF	REF	-	B	240633-1	BUSHING	67
REF	REF	-	A	455680-1	LEVER, INTERMEDIATE	66
REF	REF	-	B	240629-1	BLOCK, PIVOT	65
REF	REF	-	A	240632-2	SCR, ADJ	64
REF	REF	-	B	240659-3	PIN, CAM ROLLER	63
REF	REF	-	B	240658-1	CAM, ROLLER	62
REF	REF	-	B	454398-1	ROD, FEED	61
						60
REF	REF	-	C	454220-1	CAP, RAM	59
REF	REF	-	D	453736-1	HOUSING	58
						57
						56
REF	REF	-	B	240624-1	PIN, FEED FINGER	55
REF	REF	-	B	691499-1	SPRING, FEED FINGER	54
REF	REF	-	B	240635-1	FINGER, FEED	53
REF	REF	-	B	240634-3	LEVER, TERMINAL	52
						51
						50
						49
1	-	-	B	690501-3	CAM, POST FEED 1 1/8 ST	48
-	1	-	B	690501-4	CAM, POST-FEED 1 5/8 ST	47
						46
1	1	-	A	690191-1	PLUG, NYLON	45
1	1	-	C	455674-1	RAM	44
1	1	-	A	690125-1	WASHER, LAMINATED	43
1	1	-	A	690124-1	WASHER, RAM	42
1	1	-	A	7-21002-9	BOLT, CRIMPER (5/16-24x1.00)	41
1	1	-	A	23241-6	BALL, STEEL	40
1	1	-	A	690170-1	SPRING, COMPRESSION	39
1	1	-	C	690142-1	DISC, INSULATION	38
1	1	-	D	354777-1	WIRE DISC, PLASTIC	37
1	1	-	A	22480-5	WASHER, SPRING	36
1	1	-	B	690212-1	POST, RAM	35
						34
						33
1	1	-	D	458980-2	APPLICATOR, BASIC (SUB ASSY)	32
						31
						30
						29
1	1	-	B	3-690451-2	SPACER, STRIPPER	28
1	1	-	A	240639-1	STRIPPER	27
REF	REF	-	C	455676-1	PLATE, BASE	26
2	2	-	A	22354-8	DRAG, STUD	25
1	1	-	B	458803-2	PLATE, STRIP GUIDE	24
1	1	-	C	240825-3	PLATE, STRIP HOLD DOWN	23
2	2	-	A	4-22281-1	SPRING, DRAG	22
						21
1	1	-	A	454177-1	DRAG, STOCK	20
						19
2	2	-	C	454204-3	GUIDE, STRIP (FRONT)	18
REF	REF	-	A	454178-1	GUIDE, FEED ROD	17
REF	REF	-	A	4-22284-9	SPRING, FEED RETURN	16
						15
						14
1	1	-	C	690481-2	SPACER, HOLD DOWN	13
1	1	-	A	23846-1	SPRING, HOLD DOWN	12
1	1	-	B	240833-4	PLATE, REAR SHEAR	11
						10
1	1	-	B	690495-3	PLATE, FRONT SHEAR	9
1	1	-	D	5-240693-4	ANVIL	8
1	1	-	B	2-690474-7	BLADE, SLUG	7
1	1	-	D	2-455892-7	HOLD DOWN, TERMINAL	6
1	1	-	C	2-240641-5	SPACER, SLUG BLADE	5
1	1	-	B	238009-2	SPACER, BLOCK CRIMPER	4
1	1	-	C	2-456134-4	CRIMPER, INSULATION	3
1	1	-	B	455888-4	SPACER, CRIMPER	2
1	1	-	C	456422-1	CRIMPER, WIRE	1

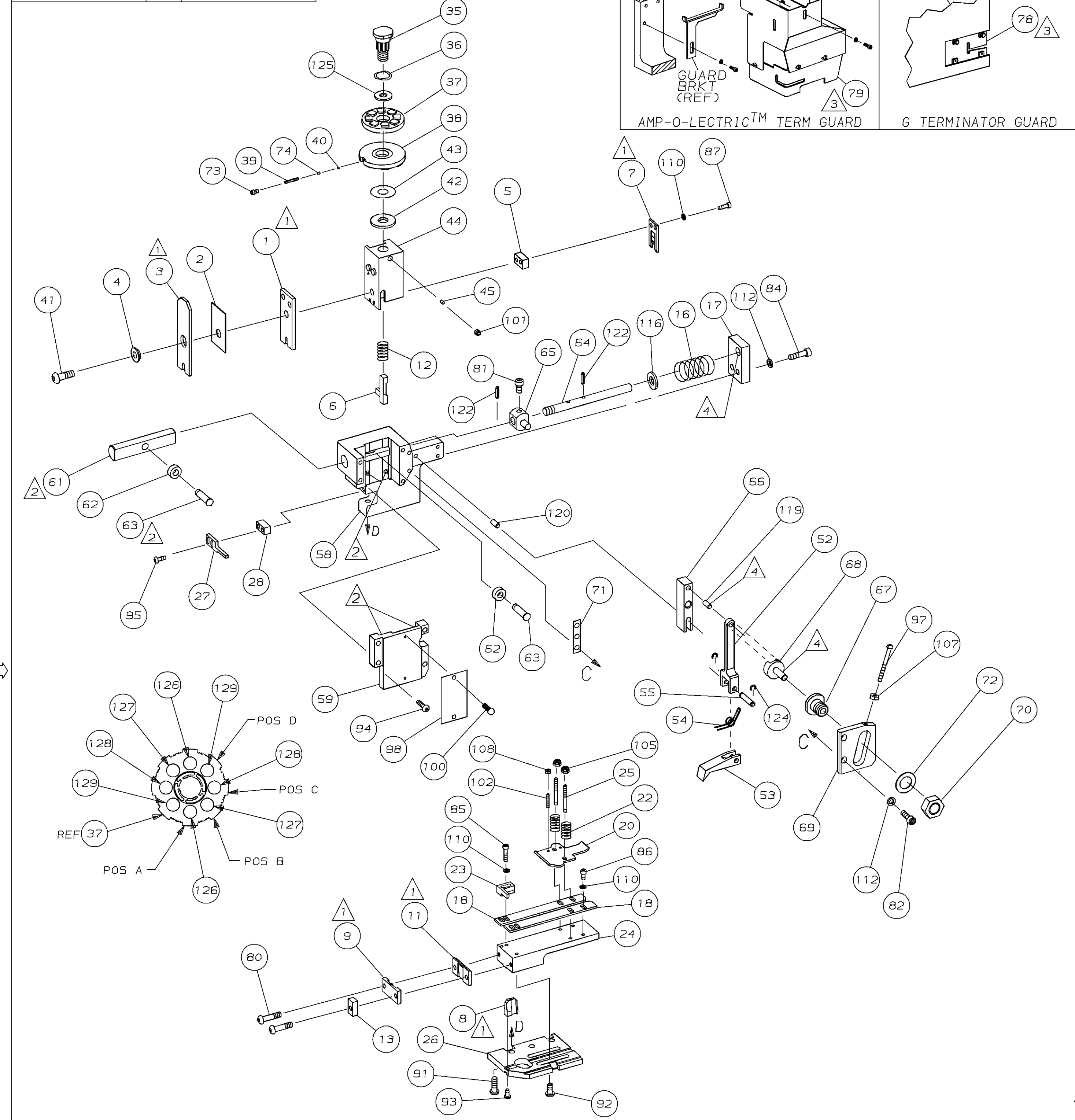

QTY	REF	U/M	DWG SIZE	PART NO	DESCRIPTION	ITEM NO
2	2	-	C	354779-8	PIN, WIRE DISC (.3030)D	129
2	2	-	C	8-354778-7	PIN, WIRE DISC (.2930)C	128
2	2	-	C	7-354778-3	PIN, WIRE DISC (.2860)B	127
2	2	-	C	5-354778-5	PIN, WIRE DISC (.2770)A	126
1	1	-	A	986950-1	WASHER, FLAT PRECISION	125
REF	REF	-	A	21045-3	RING, RET "C" (Ø.187)FD PIN	124
REF	REF	-	A	5-21028-1	PIN, STD SPRING (Ø.12)FD ADJ ROD	123
REF	REF	-	A	1-21030-7	PIN, DOWEL (Ø.187x1.50)HSG	120
REF	REF	-	A	1-21030-1	PIN, DOWEL (Ø.187x.50)LEVER	119
REF	REF	-	A	21899-4	WASHER, FLAT (Ø5/16)SCR ADJ	116
REF	REF	-	A	21024-5	WASHER, LOCK (NO.10)FD ROD GDE	112
7	7	-	A	21024-4	WASHER, LOCK (NO.8)SHEAR BL	110
2	2	-	A	21018-4	NUT, HEX (4-40)DRAG	108
REF	REF	-	A	21018-5	NUT, HEX (6-32)FD ADJ PL	107
2	2	-	A	21022-2	NUT, HEX SL (8-32)DRAG STUD	105
2	2	-	A	2-21006-6	SCR, SKT SET (4-40x.62)DRAG	102
1	1	-	A	21009-2	SCR, SKT SET (1/4-20x.25)RAM	101
2	2	-	A	21017-2	SCR, DRIVE (#2x.19)ID PLATE	100
1	1	-	A	1-21002-7	SCR, BHC (6-32x.38)CAM	99
1	1	-	B	461264-1	PLATE, IDENTIFICATION	98
REF	REF	-	A	6-23715-5	SCR, PAN HD (6-32x1.50)FEED ADJ	97
2	2	-	A	2-21002-2	SCR, BHC (8-32x.50)STRIPPER	95
REF	REF	-	A	2-21002-9	SCR, BHC (10-32x.75)HSG CAP	94
1	1	-	A	22733-8	SCR, BHC (8-32x.38 LW)ANVIL	93
4	4	-	A	3-21002-3	SCR, BHC (1/4-20x.50)ST 6D PL	92
REF	REF	-	A	2-22733-8	SCR, BHC (1/4-20x.62)BASE PL	91
REF	REF	-	A	3-21000-6	SCR, SHC (10-32x.62)FEED ADJ PL	82
REF	REF	-	A	3-21000-4	SCR, SHC (10-32x.38)PIVOT BLOCK	81
2	2	-	A	3-21002-0	SCR, BHC (10-32x.88)SHEAR PL	80
REF	REF	-	A	455745-1	GUARD, WINDOW	79
-	REF	-	A	679532-1	INSERT, GUARD	78
1	1	-	A	690603-1	SPRING, ASSIST	74
1	1	-	A	23030-1	SCR, SKT CAP (6-32x.25)CP DSC	73
REF	REF	-	A	458109-1	WASHER, FLAT (SPECIAL)	72
REF	REF	-	A	690517-1	SPACER	71
-2	-1	U/M	DWG SIZE	PART NO	DESCRIPTION	ITEM NO
QTY REQD PER ASSY						

QTY REQD PER ASSY		PARTS LIST	
QTY	REF	U/M	DWG SIZE
-2	-1	U/M	DWG SIZE
REVISION OF EACH ASSY NO (WHEN BLANK, USE DWG REVISION)			
DIMENSIONS IN INCHES. DO NOT SCALE PRINT. TOLERANCES UNLESS OTHERWISE SPECIFIED.		MACH REF MINI APPL	
DR D.SALTZER 6/21/95 APP T.BEDDICK 6-29-95		AMP Incorporated Harrisburg, PA 17105-3608	
CHK 6-29-95 REL 7/19/95		NAME END FEED HDM APPLICATOR	
3 PLC DEC +- C.ERISMAN		SCALE -	
4 PLC DEC +- ANGLE +- SURF TEXTURE: REMOVE BURRS, BREAK SHARP EDGES R.015 MAX		DWG NO 687944	
J 0150-6324-95 SF 8-95		SHEET 1 OF 1	
H 0150-6237-95 CE 6-95		REV J	
P/F LTR REVISION RECORD		DATE	

1 RECOMMENDED SPARE PARTS.
 2 GREASE LIGHTLY.
 3 GUARD MUST BE IN PLACE WHEN OPERATING APPLICATOR IN A BENCH MACHINE.
 4 LUBRICATE DAILY USING NO. 20 MACHINE OIL.
 5. ITEMS WITH QTY OF REF SPECIFIED (EXCEPT ITEMS 78 AND 79) ARE USED ON ITEM 32.
 6 ITEM 78 USED WITH G TERMINATOR ONLY.

LEADMAKER

K TERMINATOR BENCH MACHINE

G TERMINATOR BENCH MACHINE

LOC A
DIST 66
AMP 3308 REV 3-92

THIS DRAWING IS A CONTROLLED DOCUMENT FOR AMP INCORPORATED. IT IS SUBJECT TO CHANGE AND THE CONTROLLING ENGINEERING ORGANIZATION SHOULD BE CONTACTED FOR THE LATEST REVISION.

THIS INFORMATION IS CONFIDENTIAL AND IS DISCLOSED TO YOU ON CONDITION THAT NO FURTHER DISCLOSURE IS MADE BY YOU TO OTHER THAN AMP PERSONNEL WITHOUT WRITTEN AUTHORIZATION FROM AMP INCORPORATED, HARRISBURG, PA.

687944