

DESCRIPTION

Demonstration circuit 507 features the LT1937 constant-current white LED driver in a small SC70 package. The demo board consists of two circuits: an *efficiency circuit* designed to demonstrate high efficiency performance of the LT1937 using the Murata inductor and a *size circuit* highlighting the LT1937's ability to work with a small ceramic chip inductor and a small output capacitor (0.22 μ F). The high efficiency and small circuit size are made possible by a 95mV feedback voltage and 1.2MHz switching frequency, making the LT1937-SC70 an ideal

solution for battery powered portable applications such as cellular phones, digital cameras, MP3 players, GPS receivers, and handheld computers (PDAs). The DC507 is specifically designed for white LED backlight applications using 2–4 LEDs in series. LT1937 offers numerous LED-dimming circuit options, see the datasheet for more detailed information on LED brightness control.

Design files for this circuit board are available. Call the LTC factory.

QUICK START PROCEDURE

Demonstration circuit 507 is easy to set up to evaluate the performance of the LT1937. Refer to Figure 1 for proper measurement equipment setup and follow the procedure below.

NOTE: When measuring the input or output voltage ripple, care must be taken to avoid a long ground lead on the oscilloscope probe. Measure the input or output voltage ripple by touching the probe tip directly across the Vin or Vout and GND terminals. When measuring the output ripple, see Figure 2 for proper scope probe technique.

SET THE INPUT VOLTAGE SOURCE

1. The demo board can be powered from the 3V Lithium battery installed on the demo board (B1) or other input source (bench top power supply) by selecting input source jumper (JP1).
 - a. For battery (B1) input operation, place the jumper (JP1) in the BATTERY position.
 - b. For bench supply input, place the jumper (JP1) in the Vin position and connect a 3.3V, 500mA bench supply to the Vin and GND terminals.

TEST THE EFFICIENCY CIRCUIT (UPPER CIRCUIT)

2. Place jumper JP2 in the EFFICIENCY position.
3. Press the SW1 switch. Observe all four white LEDs light up. The output voltage should measure about 13V across the Vout Test terminal to GND terminal.
4. Turn off the input power supply or disconnect the single cell Li-Ion battery.

TEST THE SIZE CIRCUIT (LOWER CIRCUIT)

5. Place jumper JP2 in the SIZE position.
6. Turn on the input power supply or connect the single cell Li-Ion battery.
7. Press the SW2 switch. Observe all four white LEDs light up. The output voltage should measure about 13V across the Vout Test terminal to GND terminal.

LED BRIGHTNESS CONTROL

The brightness of the LEDs can be controlled by applying a PWM signal to the SHDN terminal (use the upper SHDN terminal for the EFFICIENCY circuit and lower SHDN terminal for the SIZE circuit). The typical frequency range recommended for PWM dimming is 1KHz–10KHz with the signal magnitude of the PWM signal higher than 1.5V. See the LT1937 data sheet for more information on PWM dimming control.

QUICK START GUIDE FOR DEMONSTRATION CIRCUIT 507

SINGLE CELL WHITE LED DRIVER

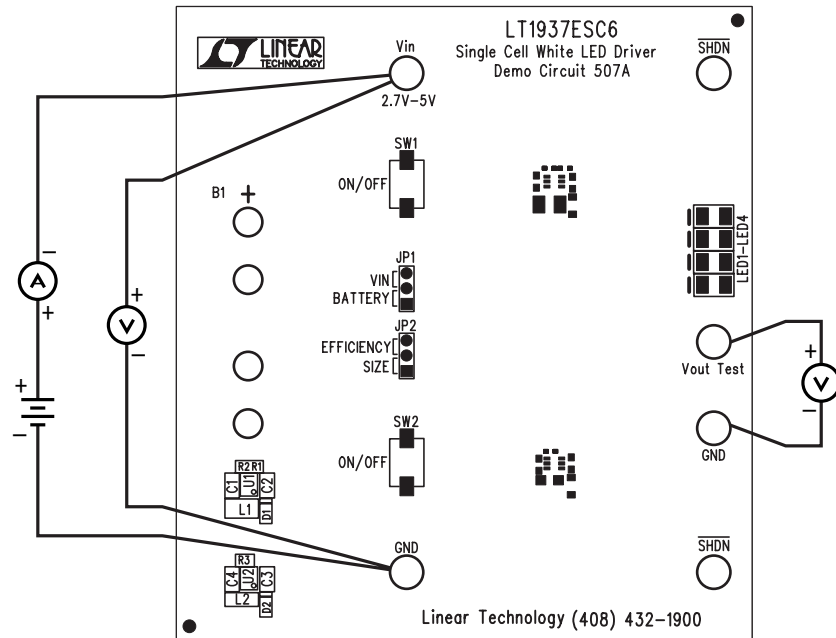

Figure 1. Proper Measurement Equipment Setup

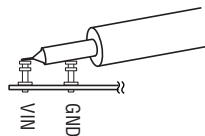
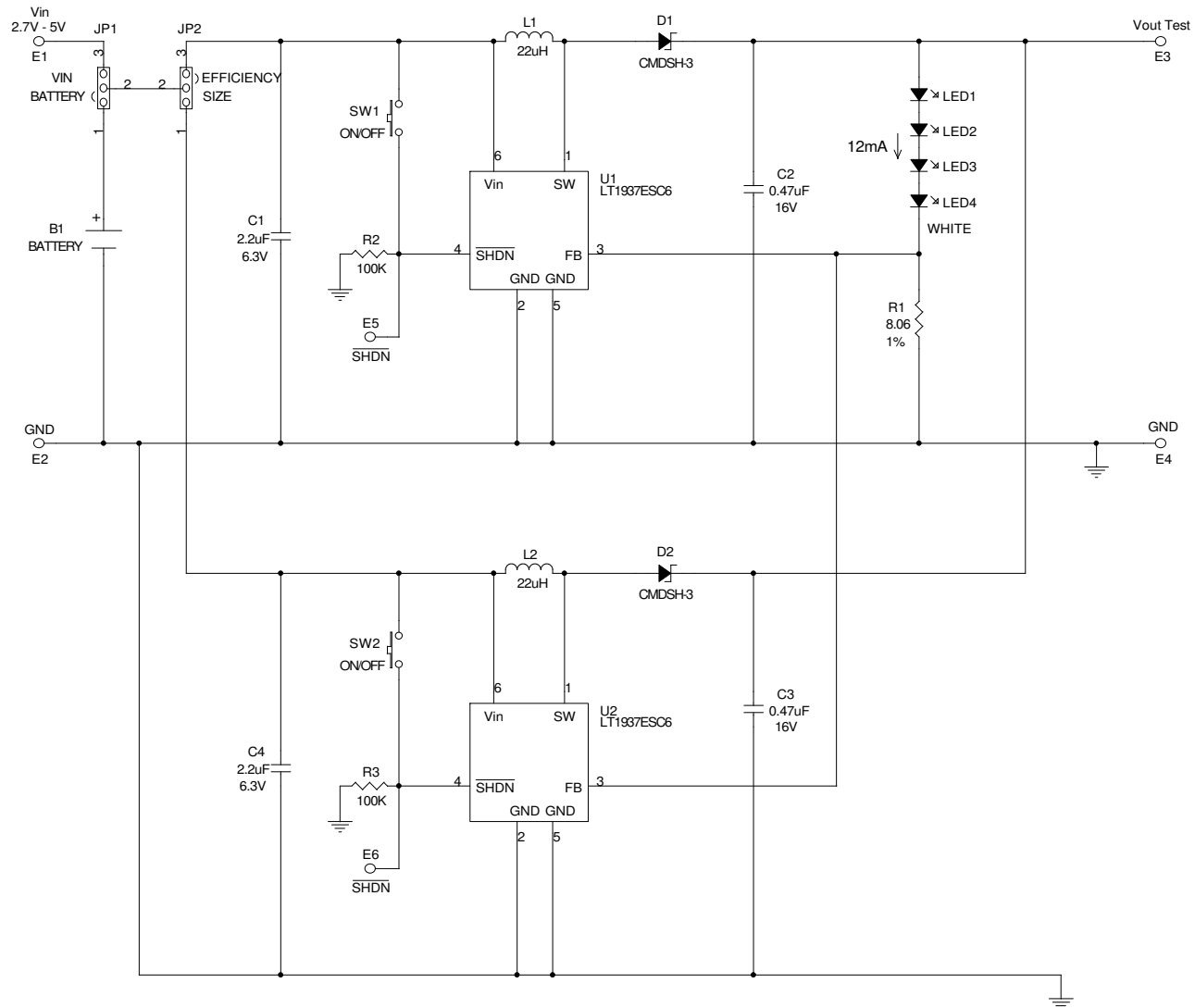



Figure 2. Scope Probe Placement for Measuring Input or Output Ripple



CONTRACT NO.		 LINEAR TECHNOLOGY 1630 McCarthy Blvd. Milpitas, CA 95035 Phone: (408)432-1900 Fax: (408)434-0507	
APPROVALS	DATE		
DRAWN June Wu	2/13/02	TITLE	
CHECKED		LT1937ESC6, SINGLE CELL WHITE LED DRIVER	
APPROVED		SIZE	CAGE CODE
ENGINEER DAVE KIM	2/13/02	DWGNO	REV
DESIGNER		DC507A	A
Thursday, March 21, 2002	SCALE:	FILENAME:	SHEET 1 OF 1

Item	Qty	Reference	Part Description	Manufacture / Part #
1	0	B1	BATTERY, AA	SANYO., CR2,
2	2	B1 HOLDER	BATTERY HOLDER,	KEYSTONE, 92
3	1	L1	INDUCTOR, 22uH	MURATA, LQH32CN220K51
4	1	L2	INDUCTOR, 22uH	TAIYO YUDEN, LB2012T220M
5	2	C1,C4	CAP., X5R, 2.2uF, 6.3V, 20% 0603	AVX, 06036D225MAT
6	2	C2,C3	CAP., X5R, 0.47uF, 16V 20% 0603	AVX, 0603YD474MAT
7	2	D1,D2	DIODE, CMDSH-3, SOD-323	Central Semi. CMDSH-3
8	6	E1,E2,E3,E4,E5,E6	TESTPOINT, TURRET, .094"	MILL-MAX, 2501-2
9	2	JP1,JP2	JUMPER, 0.079, 3 PIN	COMM CON, 2802S-03G1
10	2	JP1,JP2	SHUNT,	COMM CON. CCIJ2MM-138G
11	4	LED1-LED4	LED, NSCX SERIES, WHITE	NICHIA, NSCW100
12	1	R1	RES., CHIP, 8.06, 1/16W, 1% 0402	AAC., CR05-8R06FM
13	2	R2,R3	RES., CHIP, 100K, 1/16W, 5% 0402	AAC., CR05-104JM
14	2	SW1,SW2	SWITCH MOMENTARY	PANASONIC EVQ PJS 05K
15	2	U1,U2	IC., LT1937ESC6, SC70	LINEAR., LT1937ESC6
16	1		PRINTED CIRCUIT BOARD	DEMO CIRCUIT 507A