

ASSEMBLY NUMBER	CB NUMBER	A THREAD PLATED CLASS 2A	B MIN FULL THD	C +.016 -.047	K +.020 -.010	L	M +.010 -.000	R ±.005	S	T DIA +.004 -.002	V THREAD PLATED CLASS 2A	Z +.050 -.060
10-68308-		NOT AVAILABLE										
10-68310-	3100-10S-	.6250-24 NEF	.391	.492	.672	.969	.563	.719	1.000	.120	.5000-28 UNEF	.422
10-68311-	-10SL-	.6250-24 NEF	.391	↓	↓	↓	.562	.719	1.000		.6250-24 NEF	↓
10-68312-	-12S-	.7500-20 UNEF	.450	↓	↓	↓	.563	.812	1.094		.6250-24 NEF	↓
10-68313-	-12-	.7500-20 UNEF	.625	.679	.860	1.344	.750	.812	1.094		.6250-24 NEF	.672
10-68314-	-14S-	.8750-20 UNEF	.450	.492	.672	.969	.563	.906	1.188		.7500-20 UNEF	.422
10-68315-	-14-	.8750-20 UNEF	.625	.679	.860	1.344	.750	.906	1.188		.7500-20 UNEF	.672
10-68316-	-16S-	1.0000-20 UNEF	.450	.492	.672	.969	.562	.969	1.281		.8750-20 UNEF	.422
10-68317-	-16-	1.0000-20 UNEF	.625	.679	.860	1.344	.750	.969	1.281		.8750-20 UNEF	.672
10-68318-	-18-	1.1250-18 NEF			.891	1.344		1.063	1.375		1.0000-20 UNEF	.641
10-68320-	-20-	1.2500-18 NEF			↓	↓	↓	1.156	1.500		1.1250-18 NEF	↓
10-68322-	-22-	1.3750-18 NEF			↓	↓	↓	1.250	1.625		1.2500-18 NEF	↓
10-68324-	-24-	1.5000-18 NEF			.953	1.406	.813	1.375	1.750	.147	1.3750-18 NEF	.578
10-68328-	-28-	1.7500-18 NS			.953	1.406	.812	1.562	2.000	.147	1.6250-18 NEF	.578
10-68332-	-32-	2.0000-18 NS			1.032	1.469	.875	1.750	2.250	.173	1.8750-16 N	.500
10-68336-	-36-	2.2500-16 UN			1.031	1.469	.875	1.938	2.500	.173	2.0625-16 N	.500
10-68340-		NOT AVAILABLE										

REL NO 30508-99		REVISIONS		
CHG NO.	SYM	DESCRIPTION	DATE	APPROVED
38525-471	A2	PROVIDED SERIES COMPOSITE DRAWING REPLACING SHELL SIZE COMPOSITE DRAWINGS	3-7-62	K HISCOTT
42762-1	A3	WAS TEST 9-3107-3 & ASSY 9-3104-1 (PRO SPEC); REV NOTE 8	3-12-64	Randall Haye
47525-818	A4	ADDED THERMO & COAXIAL DATA BLOCK, SPECIAL & THERMO. SOLDER WELL DATA; DISCARDED INDIVIDUAL DWGS 10-68312-51 & -54	7-14-67	Whitney

ACCESSORIES
(NOT PART OF STANDARD ASSEMBLY)

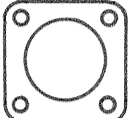

FLANGE GASKET,
PLAIN
10-40450 - (SHELL SIZE)

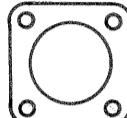

FLANGE GASKET,
SHIELDED
10-40450 - (SHELL SIZE)

CONTACT DATA (WHERE APPLICABLE)

THERMOCOUPLE		COAXIAL	
MATERIAL	IDENTIFICATION	ARR	CABLE
CHROMEL	WHITE		
ALUMEL	GREEN		
IRON	BLACK		
CONSTANTAN	YELLOW		

INSERT ARRANGEMENTS CONTAINING THERMOCOUPLE OR COAXIAL CONTACTS MUST HAVE SUCH CONTACTS ASSEMBLED INTO THE INSERT IN PROPER LOCATIONS AS SPECIFIED BY APPLICABLE DRAWING L-11908-() THRU L-11943-().

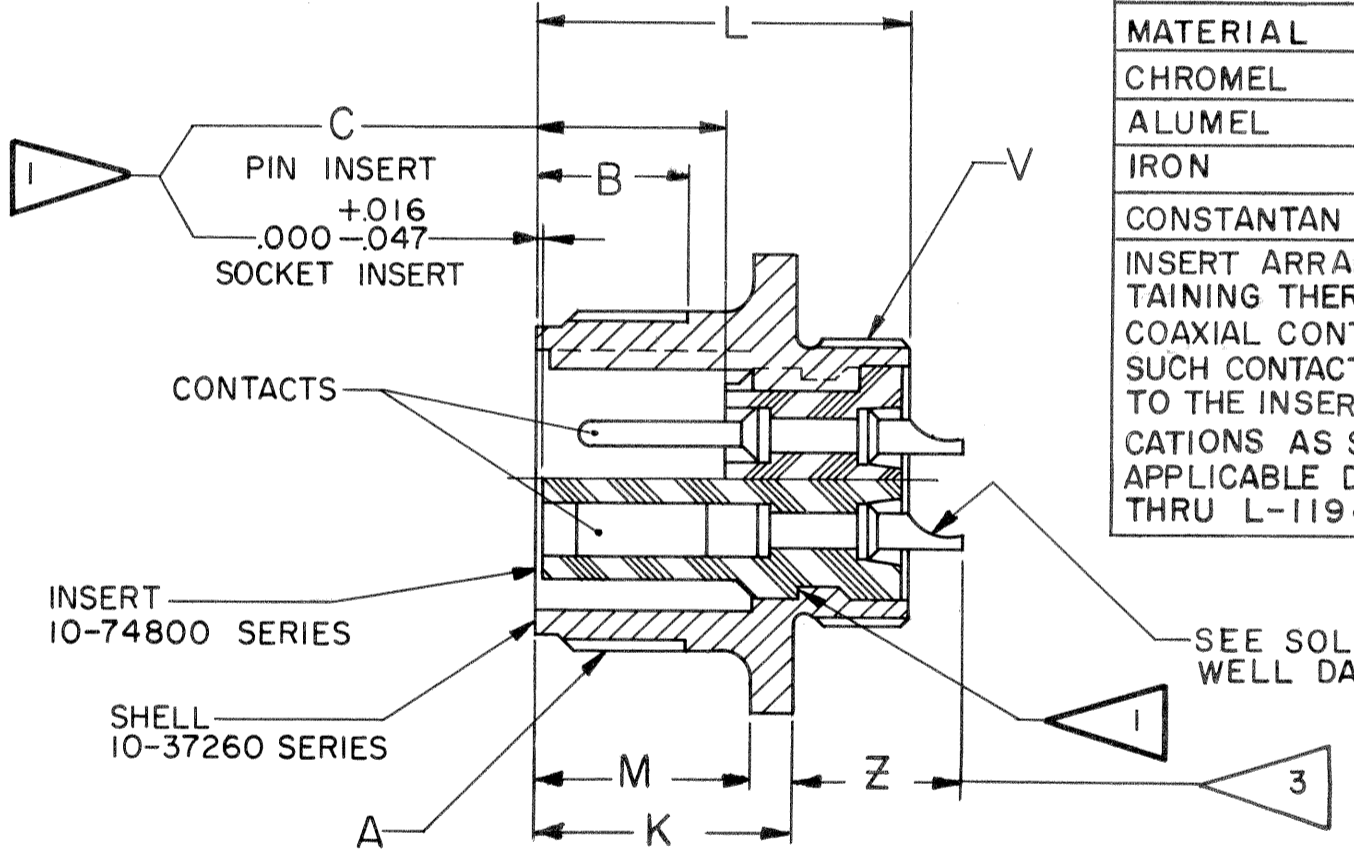
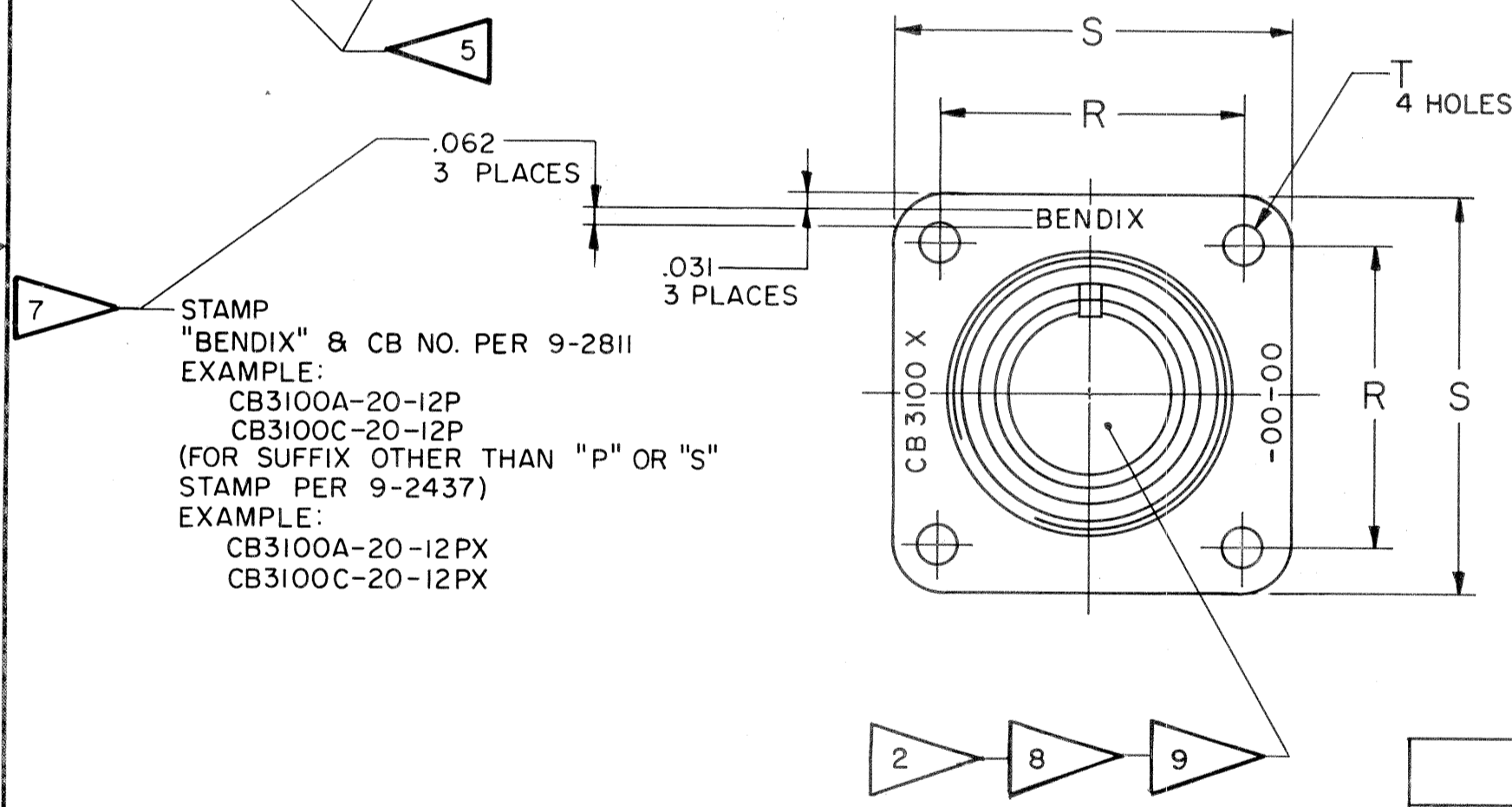

- SEE WORK ORDER FOR PERMISSIBLE ADDITIONAL OR ALTERNATE STAMPING.
 - UNITS ILLUSTRATED MEET THE MATERIAL & FINISH REQUIREMENTS OF MIL-C-5015D.
 - TO COMPLETE ASSEMBLY NUMBER & CB NO. ADD APPLICABLE INSERT ARRANGEMENT SUFFIX TO BASE NUMBERS LISTED ABOVE. (FOR ALTERNATE ARRANGEMENT REFER TO 9-2437). TO DETERMINE DESIRED INSERT ARRANGEMENT, SEE PARTS LISTS 10-68308/40.
 - SEE DRAWINGS 10-68608/40 & OTHERS FOR REQUIRED MATING PLUG ASSEMBLIES.
 - INCREASE Z DIMENSION BY .312 FOR SIZE "0" CONTACT ONLY.
 - FOR CONTACT SIZE, SPACING & SERVICE RATING, SEE DRAWINGS AND10425 THRU AND10435.
 - DIMENSIONS MUST BE MAINTAINED WHEN INSERTS ARE PRESSED FIRMLY AGAINST INDICATED SHOULDER.
- NOTES: REF SYMBOL ◁

- ALL 10- & 61- ASSEMBLIES TO BE ASSEMBLED PER 9-3103-1 AND TESTED PER 9-3106-5. INSERTS AND CONTACTS ARE REMOVABLE.
- ALL 62- ASSEMBLIES TO BE ASSEMBLED PER 9-3238-1 AND TESTED PER 9-3106-4. INSERTS AND CONTACTS ARE NOT REMOVABLE.

CONTACT SIZE	STANDARD SOLDER WELL DATA					SPECIAL SOLDER WELL DATA			THERMOCOUPLE	
	0	4	8	12	16	8 FOR #6 WIRE	12 FOR #10 WIRE	16 FOR #12 WIRE	12	16
WELL DIA	.469 ^{+.005} _{-.003}	.332 ^{+.005} _{-.003}	.209 ^{+.004} _{-.002}	.116 ^{+.004} _{-.002}	.078 ^{+.004} _{-.002}	.250±.003	.152 ^{+.004} _{-.002}	.109 ^{+.004} _{-.000}	.125 ^{+.004} _{-.002}	.094 ^{+.004} _{-.002}
WELL DEPTH	.625	.625	.500	.375	.250	.500	.250	.188	.250	.188

ITEM NO.	QTY REQD	DESCRIPTION	PART NUMBER	CODE IDENT	ZONE
PARTS LIST					
UNLESS OTHERWISE SPECIFIED			NEXT ASSEMBLY		
LINEAR DIMENSIONS ARE IN INCHES. TOLERANCES: 3 PLACES ±.010; 2 PLACES ±.03; 1 PLACE ±.1; ANGLES ±2°. OTHER STANDARDS PER SCINTILLA SPEC 9-3800 AND MIL-STD 8.		DRAWN: J. RUSSO CHECKED: R. Black MATERIAL:	DATE: 12-26-61 DATE: 12-28-61	THE Bendix CORPORATION SCINTILLA DIVISION SIDNEY, NEW YORK, U.S.A.	
MATERIAL SPEC		STANDARDS: TEST 9-3106-5 9-3106-4 ASSY 9-3103-1 9-3238-1 SEE NOTES 8 & 9 9-2437, 9-2811		TITLE: CONNECTOR, ELECTRICAL RECEPTACLE, TYPE CB () FW	
		CODE IDENT NO. 77820 SIZE C		10-68308 THRU 10-68340	
		SCALE NONE WT SEE PARTS LIST		REF 10-41308/40 SHEET	