

REVISION			
REV	DESCRIPTION	DATE	APPROVED
C	REVISED PER DCR# T-32207	NOV/20/03	M.HIGGY
D	REDRAWN, REVISE PER DCR# C060662	AUG/10/06	M.HIGGY

NOTE:

- THIS CONTACT IS DESIGNED TO MEET THE APPLICABLE REQUIREMENTS OF RAYCHEM SPECIFICATION C-6114 AND C-6115.
- MATERIAL:
BODY: COPPER ALLOY CDA C19160 (BOILLAT C97), TESTED PER ASTM B 249.
- FINISH:
BODY: GOLD PLATE PER ASTM B 488, CLASS 1
- CRIMP TOOL RECOMMENDATION:
A: TOOL NUMBER M22520/2-01
B: POSITIONER NUMBER CTA-0148 (DANIELS #K817)
- THIS CONTACT MATES WITH TYCO SOCKET CONTACT NUMBER CTA-0094
- CRIMP BARREL DESIGNED TO ACCOMMODATE A WIRE RANGE OF AWG 20-24
- CONFIGURATION CONTROL ES 71001 APPLIES.
- THESE CONTACTS ARE USED IN TYCO INSERTS MTC100-YC1-001, MTC100-YC1-002 AND MTC100-YC1-005. SEE DRAWING D-659-0097 FOR INSERT CONFIGURATION.
- RECOMMENDED WIRE STRIP LENGTH: 0.195-0.215 [4.95-5.46].

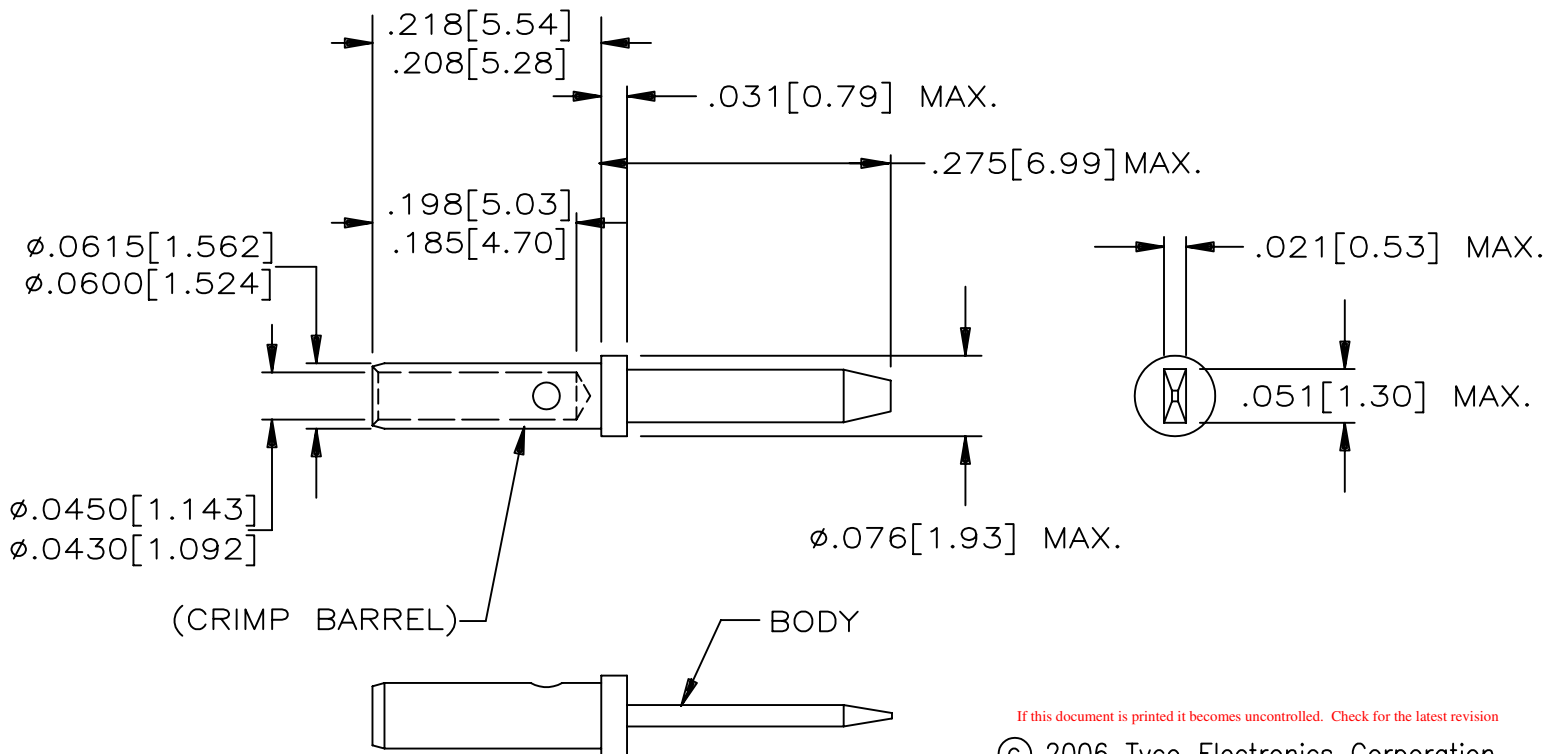

SPECIFICATION CONTROL DRAWING

ITEM	QTY.	PART NO	DWG OR SPEC NO	DESCRIPTION		
PARTS LIST						
UNLESS OTHERWISE SPECIFIED DIMENSIONS ARE INCHES. METRIC DIMENSIONS ARE IN BRACKETS.		DRAWN ZS.ORBAN DATE Aug/4/06		TYCO ELECTRONICS 300 Constitution Drive Menlo Park, CA. 94025 USA		
DECIMAL TOLERANCES .XXX ± [mm] .XX ± [mm] .X ± [mm]		APPROVED M.HIGGY DATE Aug/4/06				CONTACT. PIN. CRIMP. SIZE 22-20 MTC100 SERIES
ANGLE TOLERANCE .X ±		MATERIAL	TITLE CTA-0093			
WEIGHT 0.092 Gram Max.		FINISH				SIZE A
CAD FILE C060662.DWG		THIRD ANGLE PROJECTION			DO NOT SCALE THIS DRAWING	SHEET 1 OF 1