

REV.	DATE	ECR NO.	DESCRIPTION
NC	04/21/09	XXXXXX	INITIAL RELEASE

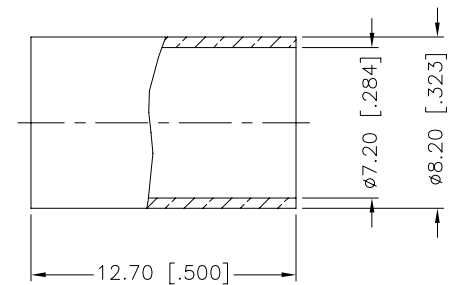
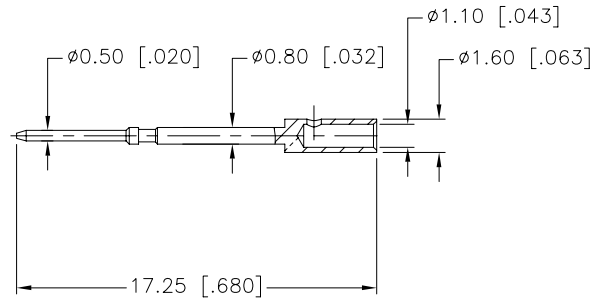
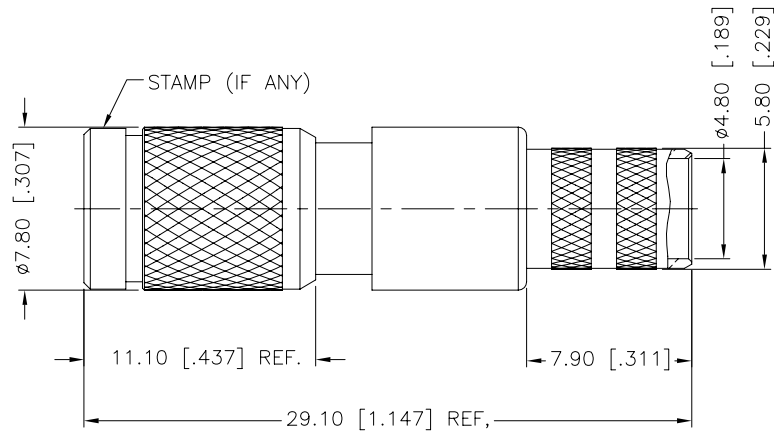
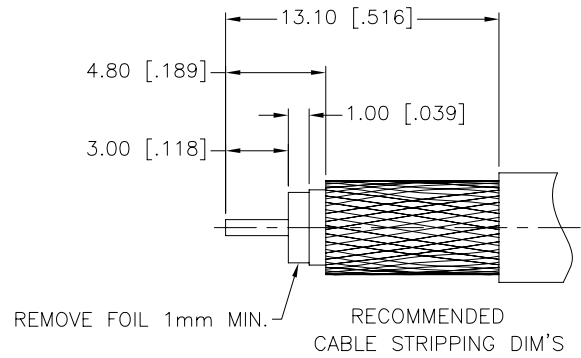

1. CRIMPED FERRULE  
HEX CRIMP SIZE .278"
2. CRIMPED CONTACT PIN  
HEX CRIMP SIZE .052"

8	FERRULE	BRASS	NICKEL	1
7	CONTACT PIN	BRASS	GOLD	1
6	BARREL	BRASS	NICKEL	1
5	OUT CONTACT	BER. COPPER	GOLD	1
4	INSULATOR	PTFE	NATURAL	1
3	SPRING	BER. COPPER	NATURAL	1
2	BODY	BRASS	NICKEL	1
1	SHELL	BRASS	NICKEL	1
	DESCRIPTION	MATERIAL	FINISH	QTY

UNLESS OTHERWISE SPECIFIED DIMENSIONS ARE IN MILLIMETERS. DIMENSIONS IN [ ] ARE IN INCHES AND FOR CUSTOMER REFERENCE ONLY.

UNLESS OTHERWISE SPECIFIED TOLERANCES FOR MILLIMETERS ARE:  
0.5 - 8mm ± 0.20mm  
8 - 30mm ± 0.40mm  
30 - 120mm ± 0.50mm

UNLESS OTHERWISE SPECIFIED TOLERANCES FOR INCHES ARE:  
.020 - .315 = ± 0.007"  
.315 - 1.180 = ± 0.015"  
1.180 - 4.724 = ± 0.020"

DO NOT SCALE DRAWING

APPROVALS		DATE
DRAWN	M.ZHANG	04/21/09
CHECKED		
ISSUED		
SHEET	1 OF 1	
CAD FILE	C:/CONNEX/282125-75.DWG	

# Amphenol Connex

PART DESCRIPTION

1.0/2.3 PUSH-PULL CRIMP PLUG  
(FOR BELDEN 1694A CABLE)

PART NO.

282125-75

DWG. NO. 282125-75.DWG

REV. NC

SIZE A

SCALE NA