

DESCRIPTION: FEMALE - SOLDER CUP / MACHINED - PREMIUM

WILL ACCEPT 26-20 AWG WIRE

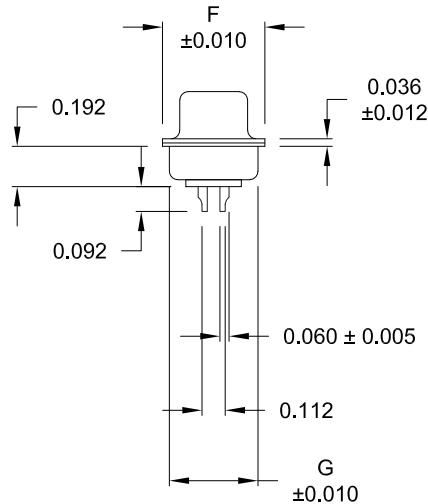
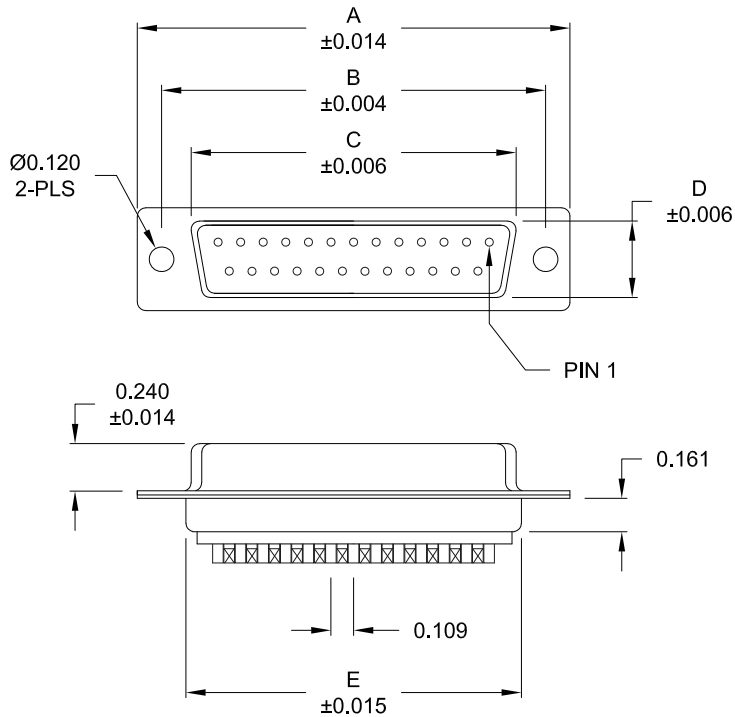

**MATERIAL:**

SHELL: STEEL, TIN PLATED  
 INSULATOR: UL 94V-O RATED, PA6T  
 PROCESS TEMP.: 260°C  
 CONTACT: BRASS

**ELECTRICAL:**

CURRENT RATING: 5 AMPS  
 CONTACT RESISTANCE: 15 mOhms Max.  
 INSULATION RESISTANCE: 1,000 MOhms Min.  
 VOLTAGE: 500VAC FOR 1 MINUTE  
 TEMPERATURE: -50° C TO 100° C

RoHS COMPLIANT



**DIMENSIONS**

No. OF PINS	A	B	C	D	E	F	G
9	1.213	0.984	0.642	0.315	0.760	0.496	0.429
	30.80	24.99	16.30	8.00	19.30	12.60	10.90
15	1.541	1.312	0.969	0.315	1.083	0.496	0.429
	39.15	33.32	24.60	8.00	27.51	12.60	10.90
25	2.088	1.852	1.512	0.315	1.630	0.496	0.429
	53.04	47.04	38.40	8.00	41.40	12.60	10.90
37	2.729	2.500	2.157	0.315	2.276	0.496	0.429
	69.32	63.50	54.80	8.00	57.81	12.60	10.90
50	2.635	2.406	2.059	0.425	2.182	0.598	0.535
	66.93	61.11	52.30	10.80	55.42	15.20	13.60

172-YYY-202RYY1

SERIES \_\_\_\_\_  
 POSITIONS \_\_\_\_\_  
 009  
 015  
 025  
 037  
 050  
 GENDER \_\_\_\_\_  
 2 = FEMALE  
 TERMINATION \_\_\_\_\_  
 0 = SOLDER CUP  
 SHELL PLATING \_\_\_\_\_  
 2 = TIN  
 RoHS COMPLIANT \_\_\_\_\_  
 HARDWARE OPTIONS \_\_\_\_\_  
 00 = NO HARDWARE  
 01 = .065" CLINCH NUT (SOLDER SIDE)  
 02 = .250" CLINCH NUT (SOLDER SIDE)  
 03 = .250" CLINCH NUT (MATING SIDE)  
 05 = .237" 4-40 BOARD LOCK  
 91 = .237" 4-40 SPACER/ BOARD LOCK  
 PLATING OPTIONS \_\_\_\_\_  
 1 = GOLD FLASH  
 2 = 30MICRO-INCH GOLD

DO NOT SCALE FROM DRAWING

	THESE DRAWINGS AND SPECIFICATIONS ARE THE PROPERTY OF NorComp AND SHALL NOT BE REPRODUCED, COPIED OR USED AS THE BASIS FOR THE MANUFACTURE OF SALE OF APPARATUS WITHOUT WRITTEN PERMISSION.	DRAWN: PAM JENKINS	DATE: 08-24-98
		SCALE: NTS	SHEET 1 OF 2
		DWG NO. 172-YYY-202RYY1	

ALL CLINCH-NUTS ARE 4-40 INTERNAL THREADS

01X ..... 0.065" (SOLDER SIDE)

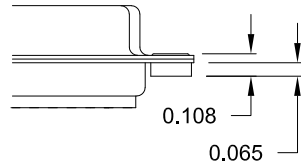

02X ..... 0.250" (SOLDER SIDE)

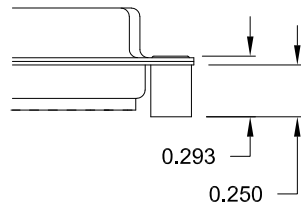

03X..... 0.250" (MATING SIDE)

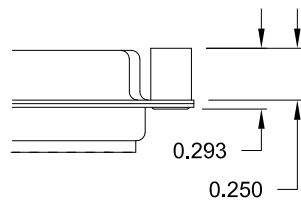

05X ..... 0.237" (SOLDER SIDE)

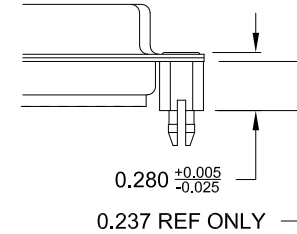

91X ..... 0.237" (SOLDER SIDE)

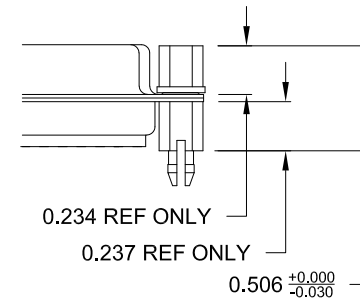

**TOLERANCE:**  
ALL DIMENSIONS ARE ±0.010  
UNLESS OTHERWISE  
SPECIFIED

NOTE: 4-40 FEMALE SCREW LOCK IS REMOVABLE

DO NOT SCALE FROM DRAWING

RoHS COMPLIANT

	THESE DRAWINGS AND SPECIFICATIONS ARE THE PROPERTY OF NorComp AND SHALL NOT BE REPRODUCED, COPIED OR USED AS THE BASIS FOR THE MANUFACTURE OF SALE OF APPARATUS WITHOUT WRITTEN PERMISSION.		DRAWN: <b>PAM JENKINS</b>	DATE: <b>08-24-98</b>
	<h1>NorComp</h1>		SCALE: NTS	SHEET OF 2 2
DWG NO. <b>172-YYY-202RYY1</b>				