

## Features

- \* Low power consumption.
- \* High efficiency.
- \* Versatile mounting on p.c. board or panel.
- \* I.C. compatible/low current requirement.
- \* 3.1 mm diameter package.

## Package Dimensions

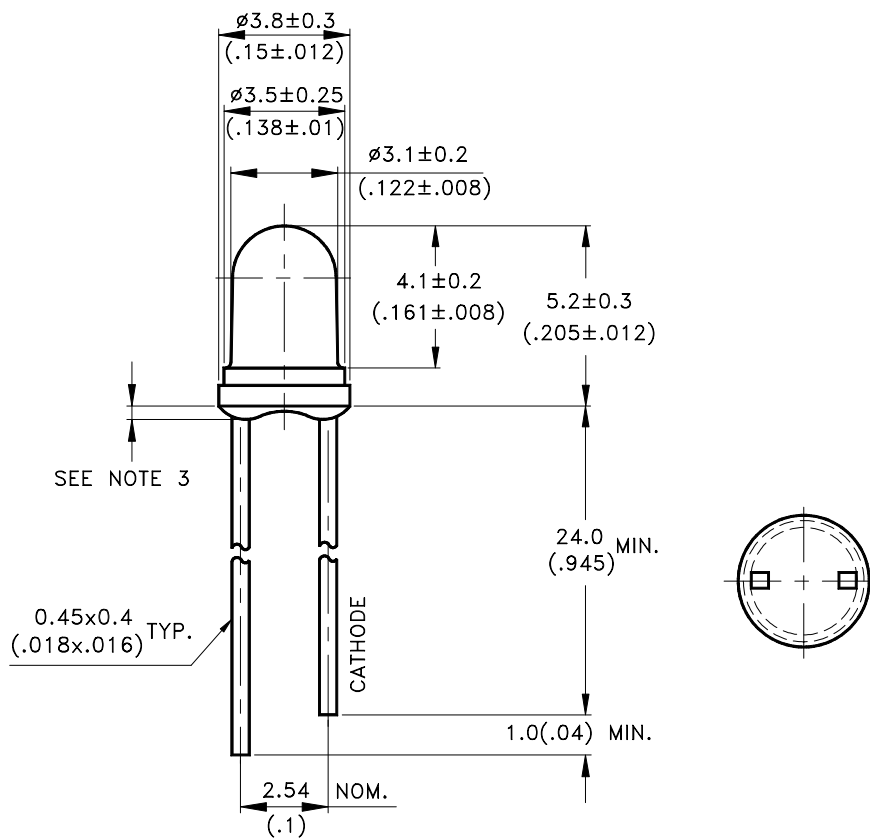

Part No.	Lens	Source Color
LTL1CHTBK2	Water Clear	Blue

### Notes:

1. All dimensions are in millimeters (inches).
2. Tolerance is  $\pm 0.25$  mm ( $.010$  inches) unless otherwise noted.
3. Protruded resin under flange is  $1.0$  mm ( $.04$  inches) max.
4. Lead spacing is measured where the leads emerge from the package.
5. Specifications are subject to change without notice.



# LITE-ON TECHNOLOGY CORPORATION

Property of Lite-On Only

## Absolute Maximum Ratings at TA=25°C

Parameter	Maximum Rating	Unit
Power Dissipation	135	mW
Peak Forward Current (1/10 Duty Cycle, 0.1ms Pulse Width)	100	mA
Continuous Forward Current	30	mA
Reverse Voltage	5	V
Electrostatic Discharge Threshold(HBM) <sup>Note A</sup>	400	V
Operating Temperature Range	-25°C to + 80°C	
Storage Temperature Range	-30°C to + 100°C	
Lead Soldering Temperature [1.6mm(.063") From Body]	260°C for 5 Seconds	

Note A :

HBM : Human Body Model. Seller gives no other assurances regarding the ability of Products to withstand ESD.

## Electrical / Optical Characteristics at T<sub>A</sub>=25°C

Parameter	Symbol	Min.	Typ.	Max.	Unit	Test Condition
Luminous Intensity	I <sub>v</sub>	85			mcd	I <sub>F</sub> = 20mA Note 1,5
Viewing Angle	2θ <sub>1/2</sub>		30		deg	Note 2 (Fig.6)
Peak Emission Wavelength	λ <sub>P</sub>		468		nm	Measurement @Peak (Fig.1)
Dominant Wavelength	λ <sub>d</sub>		470		nm	Note 3
Spectral Line Half-Width	Δλ		25		nm	
Forward Voltage	V <sub>F</sub>		4.0	4.5	V	I <sub>F</sub> = 20mA
Reverse Current	I <sub>R</sub>			150	μA	V <sub>R</sub> = 5V

- NOTE: 1. Luminous intensity is measured with a light sensor and filter combination that approximates the CIE eye-response curve.
2. θ<sub>1/2</sub> is the off-axis angle at which the luminous intensity is half the axial luminous intensity.
3. The dominant wavelength, λ<sub>d</sub> is derived from the CIE chromaticity diagram and represents the single wavelength which defines the color of the device.
4. I<sub>v</sub> classification code is marked on each packing bag.
5. The I<sub>v</sub> guarantee should be added ±15% tolerance.
6. Precautions in handling:
- When soldering, leave 2mm of minimum clearance from the resin to the soldering point.
  - Dipping the resin to solder must be avoided.
  - Correcting the soldered position after soldering must be avoided.
  - In soldering, do not apply any stress to the lead frame particularly when heated.
  - When forming a lead, make sure not to apply any stress inside the resin.
  - Lead forming must be done before soldering.
  - It is necessary to cut the lead frame at normal temperature.
7. Caution in ESD:  
Static Electricity and surge damages the LED. It is recommend to use a wrist band or anti-electrostatic glove when handling the LED. All devices, equipment and machinery must be properly grounded.

## Typical Electrical / Optical Characteristics Curves

(25°C Ambient Temperature Unless Otherwise Noted)

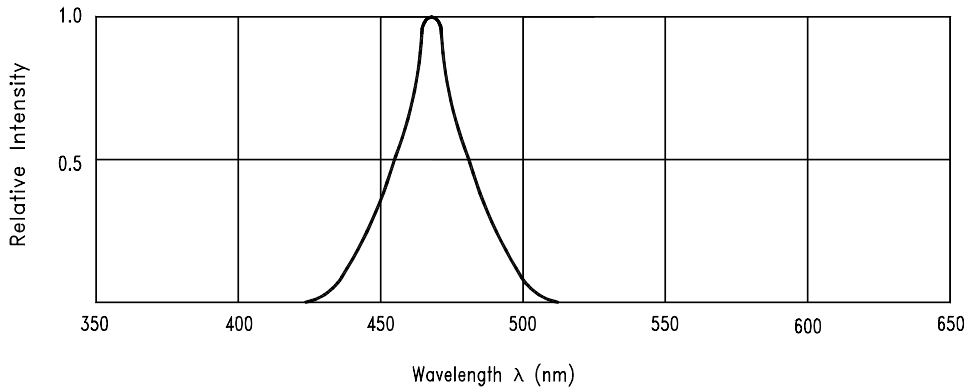

Fig.1 Relative Intensity vs. Wavelength

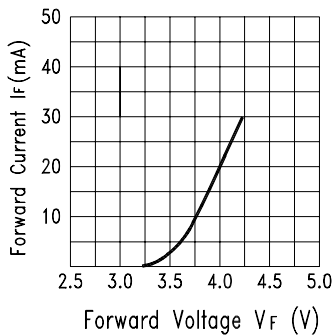

Fig.2 Forward Current vs. Forward Voltage

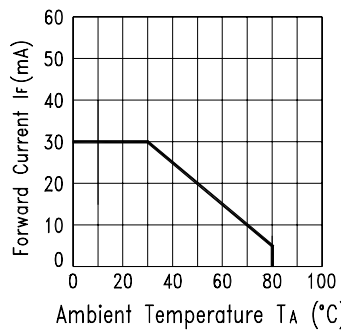

Fig.3 Forward Current Derating Curve

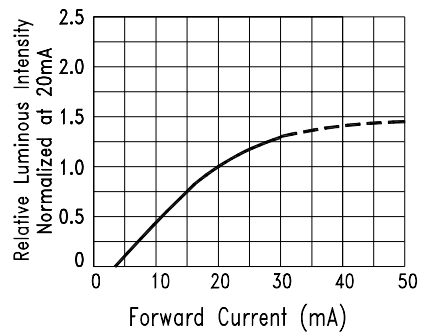

Fig.4 Relative Luminous Intensity vs. Forward Current

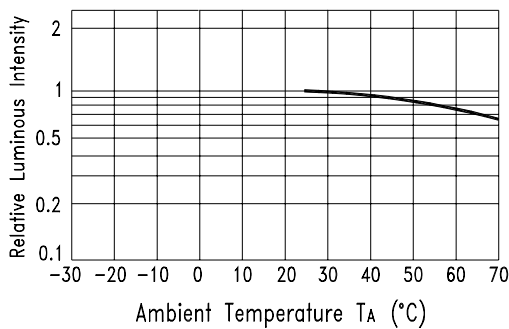

Fig.5 Luminous Intensity vs. Ambient Temperature

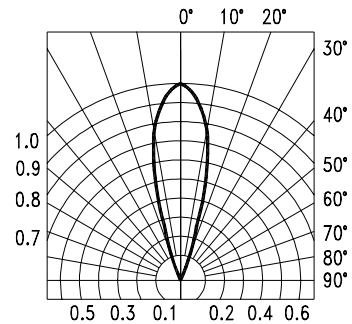
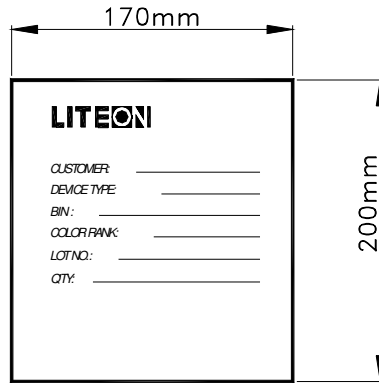

Fig.6 Spatial Distribution

## Packing Spec

**1000, 500 or 250 pcs per packing bag**



**10 packing bags per inner carton  
total 10000 pcs per inner carton**

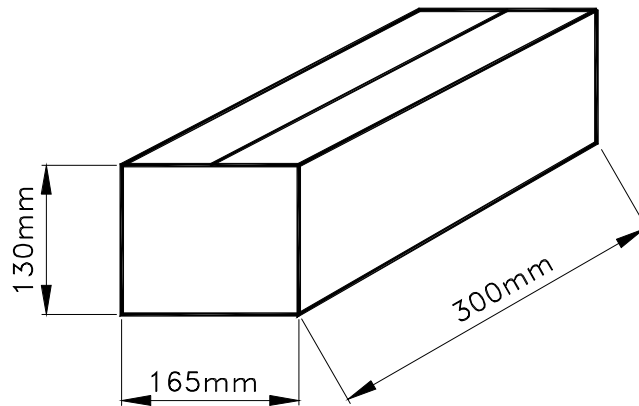

**8 Inner cartons per outer carton  
total 80000 pcs per outer carton**

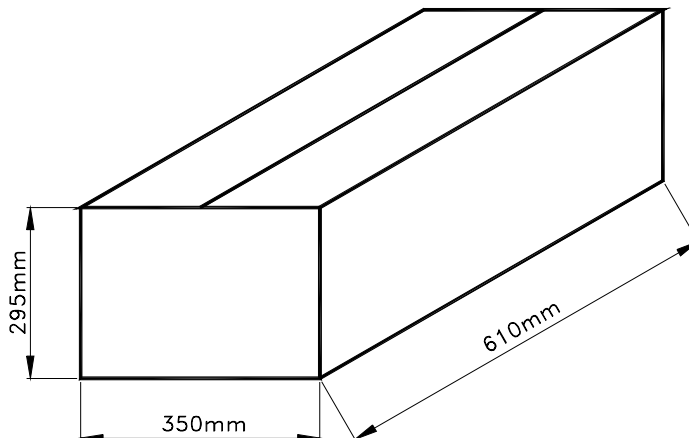

**Bin Code List For Reference**

Luminous Intensity		Unit : mcd @20mA
Bin Code	Min.	Max.
E	85	110
F	110	140
G	140	180
H	180	240
J	240	310
K	310	400

Dominant Wavelength		Unit : nm @20mA
Bin Code	Min.	Max.
B08	460.0	470.0
B09	470.0	480.0

## CAUTIONS

### 1. Application limitation

The LEDs described here are intended to be used for ordinary electronic equipment (such as office equipment, communication equipment and household application.) Consult Liteon's sales in advance for information on application in which exceptional quality and reliability are required, particularly when the failure or malfunction of the LEDs may directly jeopardize life or health (such as airplanes, automobiles, traffic control equipment, life support system and safety devices).

### 2. Storage

After being shipped from Liteon the LEDs should be kept at 30°C or less and 70%RH or less.

The LEDs should be used within 3 months. They can be stored for a year in a sealed container with a nitrogen atmosphere and moisture absorbent material. Please avoid rapid transitions in ambient temperature in high humidity environments where condensation may occur.

### 3. Cleaning

Use alcohol-based cleaning solvents such as isopropyl alcohol to clean the LED.

### 4. Forming & Mounting

When forming a lead, the leads should be bent at a point at least 3mm from the base of epoxy bulb. Do not use the base of the leadframe as a fulcrum during forming. Lead forming must be done before soldering at normal temperature. When mounted through hole type LED lamp, avoid the occurrence of residual mechanical stress due to clinching as figure shown here.

### 5. Soldering

When soldering, leave a minimum of 2mm clearance from the resin to the soldering point.

Dipping the resin into the solder must be avoided.

Do not apply any stress to the lead frame during soldering while the LED is at high temperature.

Recommended soldering condition

Soldering iron		Wave soldering	
Temperature	300°C Max.	Pre-heat	100°C Max.
Soldering time	3 sec. Max. (one time only)	Pre-heat time	60 sec. Max.
		Solder wave	260°C Max.
		Soldering time	10 sec. Max.

### 6. Drive Method

LED is a current operated device, and therefore, requires some kind of current limiting incorporated into the drive circuit. This current limiting typically takes the form of a current limiter resistor placed in series with the LED. Consider worst case voltage variations that could occur across the current limiting resistor.

The forward current should not be allowed to change by more than 40% of its desired value.

**Circuit model A**

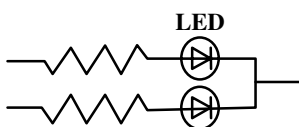

(A) Recommended circuit.

**Circuit model B**

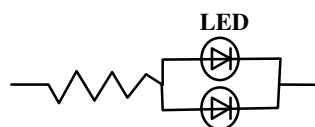

(B) The difference of brightness between LEDs could be found due to the Vf-If characteristics of LED

**7. ESD (Electrostatic Discharge)**

Static Electricity or power surge will damage the LED. Use of a conductive wrist band or anti-electrostatic glove is recommended when handling these LED. All devices, equipment and machinery must be properly grounded.

**8. Reliability Test**

Classification	Test Item	Test Condition	Duration / Cycle	Reference Standard
Endurance Test	Room Temp. Operation Life	Ta= Room Temp, IDC= 30 Ma	500 hrs	
Environmental Test	Temperature Cycling	105°C ~ 25°C ~ -55°C ~ 25°C 30mins 5mins 30mins 5mins	10 cycles	MIL-STD-202F:107D (1980) MIL-STD-750D:1051(1995) MIL-STD-883D:1010 (1991) JIS C 7021: A-4(1982)
	Solder Resistance	Solder temperature is 260± 5 °C	10 sec	MIL-STD-202F:210A(1980) MIL-STD-750D:2031(1995) JIS C 7021: A-1(1982)
	Solderability	Solder temperature is 230± 5 °C	5 sec	MIL-STD-202F:208D(1980) MIL-STD-750D:2026(1995) MIL-STD-883D:2003(1991) JIS C 7021: A-2(1982)

**9. Others**

The appearance and specifications of the product may be modified for improvement without notice.